

ThinkCentre

User Guide

Types 8095, 8096, 8141, 8142

Types 8145, 8420, 8421, 8426

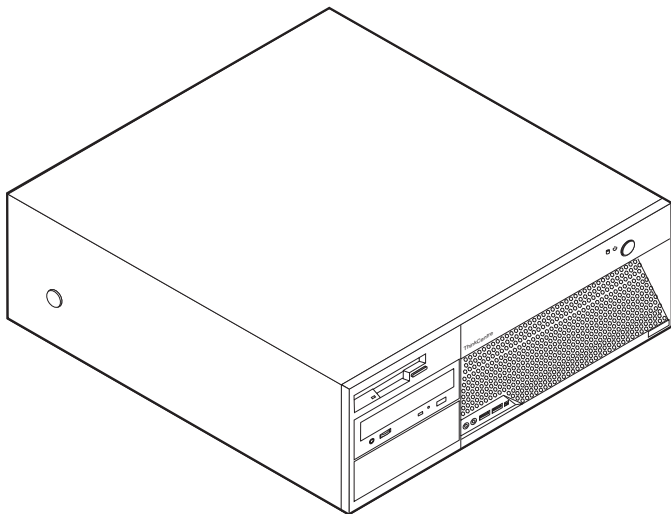

ThinkCentre

User Guide

Types 8095, 8096, 8141, 8142

Types 8145, 8420, 8421, 8426

Note

Before using this information and the product it supports, be sure to read the "Important safety information" on page v and Appendix D, "Notices," on page 41.

Sixth Edition (October 2005)

© Copyright Lenovo 2005.

Portions © Copyright International Business Machines Corporation 2004,2005.

All rights reserved.

U.S. GOVERNMENT USERS – RESTRICTED RIGHTS: Our products and/or services are provided with RESTRICTED RIGHTS. Use, duplication or disclosure by the Government is subject to the GSA ADP Schedule contract with Lenovo Group Limited, if any, or the standard terms of this commercial license, or if the agency is unable to accept this Program under these terms, then we provide this Program under the provisions set forth in Commercial Computer Software–Restricted Rights at FAR 52.227-19, when applicable, or under Rights in Data-General, FAR 52.227.14 (Alternate III).

Contents

Important safety information v

Conditions that require immediate action.	v
General safety guidelines	vi
Service	vi
Power cords and power adapters	vii
Extension cords and related devices	vii
Plugs and outlets	viii
Batteries	viii
Heat and product ventilation	ix
CD and DVD drive safety.	ix
Additional safety information.	x
Lithium battery notice	x
Modem safety information	xi
Laser compliance statement	xi
Power supply statement	xii

Overview xiii

Information resources.	xiii
--------------------------------	------

Chapter 1. Installing options 1

Features	1
Specifications	4
Available options	5
Tools required	5
Handling static-sensitive devices.	5
Installing external options	6
Locating the connectors on the front of your computer	7
Locating the connectors on the rear of your computer	8
Obtaining device drivers	9
Removing the cover	10
Locating components	11
Identifying parts on the system board	11
Installing memory	12
Installing adapters	14
Installing internal drives	16
Drive specifications.	16
Installing a drive	17
Installing security features	20
Padlock loop	21
Password protection	21
Changing the battery	21
Erasing a lost or forgotten password (clearing CMOS).	23
Replacing the cover and connecting the cables.	23

Chapter 2. Using the Setup Utility program 25

Starting the Setup Utility program.	25
Viewing and changing settings	25
Using passwords	25
Password considerations	25
User password	26
Administrator password	26
IDE Drive User Password	26
IDE Drive Master Password	26
Setting, changing, and deleting a password.	27
Using Security Profile by Device	27
Selecting a startup device.	27
Selecting a temporary startup device	28
Changing the startup sequence	28
Exiting from the Setup Utility program	28

Appendix A. Updating system programs 29

System programs	29
Updating (flashing) BIOS from a diskette	29
Updating (flashing) BIOS from your operating system	29
Recovering from a POST/BIOS update failure.	30

Appendix B. Cleaning the mouse 31

Cleaning an optical mouse	31
Cleaning a mouse with a ball	31

Appendix C. Manual modem commands 33

Basic AT commands	33
Extended AT commands	35
MNP/V.42/V.42bis/V.44 commands	36
Fax Class 1 commands	37
Fax Class 2 commands	37
Voice commands.	38

Appendix D. Notices 41

Television output notice	42
Trademarks	42

Index 43

Important safety information

Note

Please read important safety information first.

This information can help you safely use your ThinkCentre™ or ThinkPad® personal computer. Follow and retain all information included with your computer. The information in this document does not alter the terms of your purchase agreement or the Lenovo Statement of Limited Warranty.

Customer safety is important. Our products are developed to be safe and effective. However, personal computers are electronic devices. Power cords, power adapters, and other features can create potential safety risks that can result in physical injury or property damage, especially if misused. To reduce these risks, follow the instructions included with your product, observe all warnings on the product and in the operating instructions, and review the information included in this document carefully. By carefully following the information contained in this document and provided with your product, you can help protect yourself from hazards and create a safer computer work environment.

Note: This information includes references to power adapters and batteries. In addition to mobile personal computers, some products (such as speakers and monitors) ship with external power adapters. If you have such a product, this information applies to your product. In addition, your computer product may contain a coin-sized internal battery that provides power to your system clock even when the machine is unplugged, so the battery safety information applies to all computers.

Conditions that require immediate action

Products can become damaged due to misuse or neglect. Some product damage is serious enough that the product should not be used again until it has been inspected and, if necessary, repaired by an authorized servicer.

As with any electronic device, pay close attention to the product when it is turned on. On very rare occasions, you might notice an odor or see a puff of smoke or sparks vent from your machine. Or you might hear sounds like popping, cracking or hissing. These conditions might merely mean that an internal electronic component has failed in a safe and controlled manner. Or, they might indicate a potential safety issue. However, do not take risks or attempt to diagnose the situation yourself.

Frequently inspect your computer and its components for damage or wear or signs of danger. If you have any question about the condition of a component, do not use the product. Contact the Customer Support Center or the product manufacturer for instructions on how to inspect the product and have it repaired, if necessary.

In the unlikely event that you notice any of the conditions listed below, or if you have any safety concerns with your product, stop using the product and unplug it from the power source and telecommunication lines until you can

speak to the Customer Support Center for further guidance. See “Information resources” on page xiii for more information.

- Power cords, plugs, power adapters, extension cords, surge protectors, or power supplies that are cracked, broken or damaged.
- Signs of overheating, smoke, sparks or fire.
- Damage to a battery (such as cracks, dents, creases), discharge from a battery, or a buildup of foreign substances on the battery.
- A cracking, hissing or popping sound, or strong odor that comes from the product.
- Signs that liquid has been spilled or an object has fallen onto the computer product, the power cord or power adapter.
- The computer product, the power cord or power adapter has been exposed to water.
- The product has been dropped or damaged in any way.
- The product does not operate normally when you follow the operating instructions.

Note: If you notice these conditions with a product (such as an extension cord) that is not manufactured for or by Lenovo, stop using that product until you can contact the product manufacturer for further instructions, or until you get a suitable replacement.

General safety guidelines

Always observe the following precautions to reduce the risk of injury and property damage.

Service

Do not attempt to service a product yourself unless instructed to do so by the Customer Support Center. Use only a service provider who is approved to repair your particular product.

Note: Some parts can be upgraded or replaced by the customer. These parts are referred to as Customer Replaceable Units, or CRUs. Lenovo expressly identifies CRUs as such, and provides documentation with instructions when it is appropriate for customers to replace those parts. You must closely follow all instructions when performing such replacements. Always make sure that the power is turned off and that the product is unplugged from any power source before you attempt the replacement. If you have any questions or concerns, contact the Customer Support Center.

Although there are no moving parts in your computer after the power cord has been disconnected, the following warnings are required for proper UL certification.

Danger

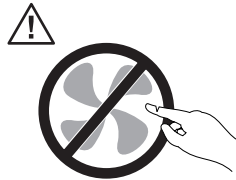

Hazardous moving parts. Keep fingers and other body parts away.

Attention



Before replacing any CRUs, turn off the computer and wait three to five minutes to let the computer cool before opening the cover.

Power cords and power adapters

Use only the power cords and power adapters supplied by the product manufacturer.

Never wrap a power cord around the power adapter or other object. Doing so can stress the cord in ways that can cause the cord to fray, crack or crimp. This can present a safety hazard.

Always route power cords so that they will not be walked on, tripped over, or pinched by objects.

Protect the cord and power adapters from liquids. For instance, do not leave your cord or power adapter near sinks, tubs, toilets, or on floors that are cleaned with liquid cleansers. Liquids can cause a short circuit, particularly if the cord or power adapter has been stressed by misuse. Liquids can also cause gradual corrosion of the power cord terminals and/or the connector terminals on the adapter which can eventually result in overheating.

Always connect power cords and signal cables in the correct order and ensure that all power cord connectors are securely and completely plugged into receptacles.

Do not use any power adapter that shows corrosion at the ac input pins and/or shows signs of overheating (such as deformed plastic) at the ac input or anywhere on the power adapter.

Do not use any power cords where the electrical contacts on either end show signs of corrosion or overheating or where the power cord appears to have been damaged in any way.

Extension cords and related devices

Ensure that extension cords, surge protectors, uninterruptible power supplies, and power strips that you use are rated to handle the electrical requirements of the

product. Never overload these devices. If power strips are used, the load should not exceed the power strip input rating. Consult an electrician for more information if you have questions about power loads, power requirements, and input ratings.

Plugs and outlets

If a receptacle (power outlet) that you intend to use with your computer equipment appears to be damaged or corroded, do not use the outlet until it is replaced by a qualified electrician.

Do not bend or modify the plug. If the plug is damaged, contact the manufacturer to obtain a replacement.

Some products are equipped with a three-pronged plug. This plug fits only into a grounded electrical outlet. This is a safety feature. Do not defeat this safety feature by trying to insert it into a non-grounded outlet. If you cannot insert the plug into the outlet, contact an electrician for an approved outlet adapter or to replace the outlet with one that enables this safety feature. Never overload an electrical outlet. The overall system load should not exceed 80 percent of the branch circuit rating. Consult an electrician for more information if you have questions about power loads and branch circuit ratings.

Be sure that the power outlet you are using is properly wired, easily accessible, and located close to the equipment. Do not fully extend power cords in a way that will stress the cords.

Carefully connect and disconnect the equipment from the electrical outlet.

Batteries

All personal computers manufactured by Lenovo contain a non-rechargeable coin cell battery to provide power to the system clock. In addition many mobile products such as ThinkPad notebook PCs utilize a rechargeable battery pack to provide system power when in portable mode. Batteries supplied by Lenovo for use with your product have been tested for compatibility and should only be replaced with approved parts.

Never attempt to open or service any battery. Do not crush, puncture, or incinerate batteries or short circuit the metal contacts. Do not expose the battery to water or other liquids. Only recharge the battery pack strictly according to instructions included in the product documentation.

Battery abuse or mishandling can cause the battery to overheat, which can cause gasses or flame to “vent” from the battery pack or coin cell. If your battery is damaged, or if you notice any discharge from your battery or the buildup of foreign materials on the battery leads, stop using the battery and obtain a replacement from the battery manufacturer.

Batteries can degrade when they are left unused for long periods of time. For some rechargeable batteries (particularly Lithium Ion batteries), leaving a battery unused in a discharged state could increase the risk of a battery short circuit, which could shorten the life of the battery and can also pose a safety hazard. Do not let rechargeable Lithium-Ion batteries completely discharge or store these batteries in a discharged state.

Heat and product ventilation

Computers generate heat when turned on and when batteries are charging. Notebook PCs can generate a significant amount of heat due to their compact size. Always follow these basic precautions:

- Do not leave the base of your computer in contact with your lap or any part of your body for an extended period when the computer is functioning or when the battery is charging. Your computer produces some heat during normal operation. Extended contact with the body could cause discomfort or, potentially, a skin burn.
- Do not operate your computer or charge the battery near flammable materials or in explosive environments.
- Ventilation slots, fans and/or heat sinks are provided with the product for safety, comfort, and reliable operation. These features might inadvertently become blocked by placing the product on a bed, sofa, carpet, or other flexible surface. Never block, cover or disable these features.

You should inspect your desktop computer for dust accumulation at least once every three months. Before inspecting your computer, turn off the power and unplug the computer's power cord from the electrical outlet; then remove any dust from vents and perforations in the bezel. If you notice external dust accumulation, you should also examine and remove dust from the inside of the computer including heat sink inlet fins, power supply vents, and fans. Always turn off and unplug the computer before opening the cover. If possible, avoid operating your computer within 2 feet of high-traffic areas. If you must operate your computer in or near a high-traffic area, you should inspect and, if necessary, clean your computer more frequently.

For your safety and to maintain optimum computer performance, always follow these basic precautions with your desktop computer:

- Keep the cover closed whenever the computer is plugged in.
- Regularly inspect the outside of the computer for dust accumulation.
- Remove dust from vents and any perforations in the bezel. More frequent cleanings might be required for computers in dusty or high-traffic areas.
- Do not block or restrict airflow into the front of the computer.
- Do not block the airflow vents on the back of the computer.
- Do not store or operate your computer inside furniture, as this might increase the risk of overheating.
- Airflow temperatures into the computer should not exceed 35° C (95° F).
- Do not use non-ThinkCentre air filtration devices.

CD and DVD drive safety

CD and DVD drives spin discs at a high speed. If a CD or DVD is cracked or otherwise physically damaged, it is possible for the disc to break apart or even shatter when the CD drive is in use. To protect against possible injury due to this situation, and to reduce the risk of damage to your machine, do the following:

- Always store CD/DVD discs in their original packaging
- Always store CD/DVD discs out of direct sunlight and away from direct heat sources
- Remove CD/DVD discs from the computer when not in use
- Do not bend or flex CD/DVD discs, or force them into the computer or their packaging

- Check CD/DVD discs for cracks before each use. Do not use cracked or damaged discs

Additional safety information

Danger

Electrical current from power, telephone, and communication cables is hazardous.

To avoid a shock hazard:

- Do not connect or disconnect any cables or perform installation, maintenance, or reconfiguration of this product during an electrical storm.
- Connect all power cords to a properly wired and grounded electrical outlet.
- Connect to properly wired outlets any equipment that will be attached to this product.
- When possible, use one hand only to connect or disconnect signal cables.
- Never turn on any equipment when there is evidence of fire, water, or structural damage.
- Disconnect the attached power cords, telecommunications systems, networks, and modems before you open the device covers, unless instructed otherwise in the installation and configuration procedures.
- Connect and disconnect cables as described in the following table when installing, moving, or opening covers on this product or attached devices.

To connect:

1. Turn everything OFF.
2. First, attach all cables to devices.
3. Attach signal cables to connectors.
4. Attach power cords to outlet.
5. Turn device ON.

To disconnect:

1. Turn everything OFF.
2. First, remove power cords from outlet.
3. Remove signal cables from connectors.
4. Remove all cables from devices.

Lithium battery notice

Caution

Danger of explosion if battery is incorrectly replaced.

When replacing the battery, use only Part Number 33F8354 or an equivalent type battery recommended by the manufacturer. The battery contains lithium and can explode if not properly used, handled, or disposed of.

Do not:

- Throw or immerse into water
- Heat to more than 100°C (212°F)
- Repair or disassemble

Dispose of the battery as required by local ordinances or regulations.

Modem safety information

Caution

To reduce the risk of fire, use only No. 26 AWG or larger telecommunication line cord.

To reduce the risk of fire, electrical shock, or injury when using telephone equipment, always follow basic safety precautions, such as:

- Never install telephone wiring during a lightning storm.
- Never install telephone jacks in wet locations unless the jack is specifically designed for wet locations.
- Never touch uninsulated telephone wires or terminals unless the telephone line has been disconnected at the network interface.
- Use caution when installing or modifying telephone lines.
- Avoid using a telephone (other than a cordless type) during an electrical storm. There may be a remote risk of electric shock from lightning.
- Do not use the telephone to report a gas leak in the vicinity of the leak.

Laser compliance statement

Some personal computer models are equipped from the factory with a CD-ROM drive or a DVD-ROM drive. CD-ROM drives and DVD-ROM drives are also sold separately as options. CD-ROM drives and DVD-ROM drives are laser products. These drives are certified in the U.S. to conform to the requirements of the Department of Health and Human Services 21 Code of Federal Regulations (DHHS 21 CFR) Subchapter J for Class 1 laser products. Elsewhere, these drives are certified to conform to the requirements of the International Electrotechnical Commission (IEC) 825 and CENELEC EN 60 825 for Class 1 laser products.

When a CD-ROM drive or a DVD-ROM drive is installed, note the following handling instructions.

Caution

Use of controls or adjustments or performance of procedures other than those specified herein might result in hazardous radiation exposure.

Removing the covers of the CD-ROM drive or DVD-ROM drive could result in exposure to hazardous laser radiation. There are no serviceable parts inside the CD-ROM drive or DVD-ROM drive. **Do not remove the drive covers.**

Some CD-ROM drives and DVD-ROM drives contain an embedded Class 3A or Class 3B laser diode. Note the following statement.

Danger

Laser radiation when open. Do not stare into the beam, do not view directly with optical instruments, and avoid direct exposure to the beam.

Power supply statement

Never remove the cover on a power supply or any part that has the following label attached.



Hazardous voltage, current, and energy levels are present inside any component that has this label attached. There are no serviceable parts inside these components. If you suspect a problem with one of these parts, contact a service technician.

Overview

Thank you for selecting a ThinkCentre computer. Your computer incorporates many of the latest advances in computer technology and can be upgraded as your needs change.

Adding hardware options to your computer is an easy way to increase its capabilities. Instructions for installing external and internal options are included in this publication. When adding an option, use these instructions along with the instructions that come along with the option.

Information resources

The *Quick Reference* that comes with your computer provides information for installing your computer and starting the operating system. It also includes basic troubleshooting information, software recovery procedures, help and service information, and warranty information.

The Access IBM[®] program, on your desktop, provides a link to more information about your computer.

If you have Internet access, the most up-to-date information for your computer is available from the World Wide Web.

You can find the following information:

- CRU removal and installation instructions
- Publications
- Troubleshooting information
- Parts information
- Downloads and drivers
- Links to other useful sources of information
- Support phone list

To access this information, point your browser to:
<http://www.lenovo.com/think/support>

Chapter 1. Installing options

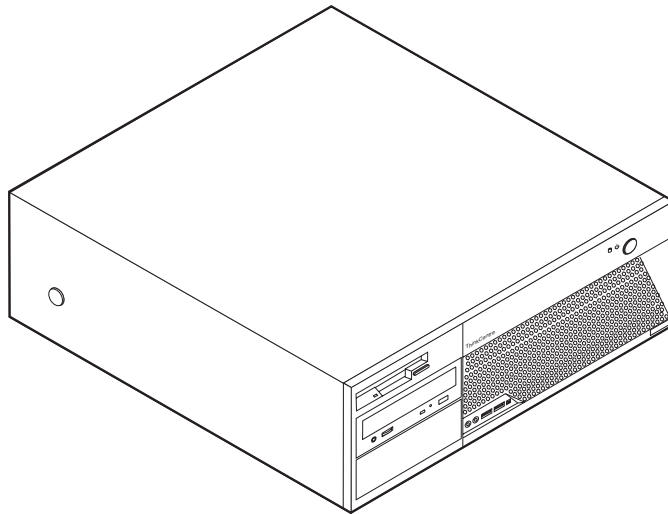

This chapter provides an introduction to the features and options that are available for your computer. You can expand the capabilities of your computer by adding memory, adapters, or drives. When installing an option, use these instructions along with the instructions that come with the option.

Important

Before you install or remove any option, read “Important safety information” on page v. These precautions and guidelines will help you work safely.

Note: Use only the parts provided by Lenovo.

Features

This section provides an overview of the computer features and preinstalled software.

System information

The following information covers a variety of models. For information for your specific model, use the Setup Utility. See Chapter 2, “Using the Setup Utility program,” on page 25.

Microprocessor (varies by model type)

- Intel® Pentium® 4 processor with HyperThreading Technology
- Intel Pentium 4 processor
- Intel Celeron® processor
- Internal cache (size varies by model type)

Memory

- Support for four double data rate (DDR or DDR2, depending on model) dual inline memory modules (DIMMs)
- 512 KB flash memory for system programs

Internal drives

- 3.5-inch, 1.44 MB diskette drive
- Serial Advanced Technology Attachment (SATA) internal hard disk drive
- Optical drive (some models)

Video subsystem

- An integrated graphics controller for a Video Graphics Array (VGA) monitor
- PCI Express (x16) graphics adapter connector on the system board

Audio subsystem

- AC'97 with ADI 1981B Audio Codec
- Line in and line out connectors on the rear panel
- Microphone and headphone connectors on the front panel

Connectivity

- 10/100/1000 Mbps integrated Broadcom Ethernet controller
- Peripheral Component Interconnect (PCI) V.90 Data/Fax modem (some models)

System management features

- Remote Program Load (RPL) and Dynamic Host Configuration Protocol (DHCP)
- Wake on LAN[®]
- Wake on Ring (in the Setup Utility program, this feature is called Serial Port Ring Detect for an external modem)
- Remote Administration
- Automatic power-on startup
- System Management (SM) BIOS and SM software
- Ability to store power-on self-test (POST) hardware test results

Input/output features

- 25-pin, Extended Capabilities Port (ECP)/Extended Parallel Port (EPP)
- Two 9-pin serial connectors (some models)
- Eight 4-pin, USB connectors (two on front panel and six on rear panel)
- Standard mouse connector
- Standard keyboard connector
- Ethernet connector
- VGA monitor connector
- Two rear panel audio connectors (line in and line out)
- Two front panel audio connectors (headphone and microphone)
- IEEE 1394 connector (some models)

Expansion

- Four drive bays
- Two 32-bit peripheral component interconnect (PCI) adapter connectors
- One PCI Express (x1) adapter connector
- One PCI Express (x16) graphics adapter connector

Power

- 310 W power supply with manual voltage selection switch
- Automatic 50/60 Hz input frequency switching
- Advanced Power Management support
- Advanced Configuration and Power Interface (ACPI) support

Security features

- User and administrator passwords for BIOS access
- User and master passwords for hard disk drive (some models)
- Support for the addition of a padlock to secure the cover
- Keyboard with fingerprint reader (some models, see the Access IBM program for more information)
- Cover presence switch (some models)
- Startup sequence control
- Startup without diskette drive, keyboard, or mouse
- Unattended start mode
- Diskette and hard disk I/O control
- Serial and parallel port I/O control
- Security profile by device

Preinstalled software

Your computer might come with preinstalled software. If it does, an operating system, device drivers to support built-in features, and other support programs are included.

Operating systems, preinstalled (varies by model type)

Note: Not all countries or regions will have these operating systems.

- Microsoft® Windows® XP Home
- Microsoft Windows XP Professional

Operating systems certified or tested for compatibility¹

Linux®

1. The operating systems listed here are being certified or tested for compatibility at the time this publication goes to press. Additional operating systems might be identified by Lenovo as compatible with your computer following the publication of this booklet. Corrections and additions to this list are subject to change. To determine if an operating system has been certified or tested for compatibility, check the Web site of the operating system vendor.

Specifications

This section lists the physical specifications for your computer.

<p>Dimensions</p> <p>Height: 146 mm (5.7 in.) Width: 442 mm (17.4 in.) Depth: 401 mm (15.8 in.)</p> <p>Weight</p> <p>Minimum configuration as shipped: 24 lb (11 kg) Maximum configuration: 31 lb (14 kg)</p> <p>Environment</p> <p>Air temperature: System on: 10° to 35°C (50° to 95° F) System off: 10° to 43°C (50° to 110° F) Maximum altitude: 914 m (3000 ft) Note: The maximum altitude, 914 m (3000 ft), is the maximum altitude at which the specified air temperatures apply. At higher altitudes, the maximum air temperatures are lower than those specified.</p> <p>Humidity: System on: 8% to 80% System off: 8% to 80%</p> <p>Electrical input</p> <p>Input voltage: Low range: Minimum: 100 V ac Maximum: 127 V ac Input frequency range: 50–60 Hz Voltage switch setting: 115 V ac High range: Minimum: 200 V ac Maximum: 240 V ac Input frequency range: 50–60 Hz Voltage switch setting: 230 V ac Input kilovolt-amperes (kVA) (approximate): Minimum configuration as shipped: 0.09 kVA Maximum configuration: 0.32 kVA</p> <p>Note: Power consumption and heat output vary depending on the number and type of optional features installed and the power-management optional features in use.</p>	<p>Heat output (approximate) in British thermal units (Btu) per hour: Minimum configuration: 256 Btu/hr (75 watts) Maximum configuration: 1058 Btu/hr (310 watts)</p> <p>Airflow</p> <p>Approximately 1.13 cubic meters per minute (40 cubic feet per minute) maximum</p> <p>Acoustical noise-emission values</p> <p>Average sound-pressure levels: At operator position: (0.5 meters) Idle: 33 dBA Operating: 35 dBA At bystander position - 1 meter (3.3 ft): Idle: 29 dBA Operating: 31 dBA Declared (upper limit) sound-power levels: Idle: 4.3 bels Operating: 4.4 bels</p> <p>Note: These levels were measured in controlled acoustical environments according to the procedures specified by the American National Standards Institute (ANSI) S12.10 and ISO 7779 and are reported in accordance with ISO 9296. Actual sound-pressure levels in a given location might exceed the average values stated because of room reflections and other nearby noise sources. The declared sound-power levels indicate an upper limit, below which a large number of computers will operate.</p>
---	---

Available options

The following are some available options:

- External options
 - Parallel port devices, such as printers and external drives
 - Serial port devices, such as external modems and digital cameras
 - Audio devices, such as external speakers for the sound system
 - USB devices, such as printers, joysticks, and scanners
 - Security device, such as a padlock
 - Monitors
- Internal options
 - System memory, called dual inline memory modules (DIMMs)
 - Peripheral component interconnect (PCI) adapters
 - PCI Express (x1) adapter
 - PCI Express (x16) graphics adapter
 - Internal drives, such as:
 - Optical drives such as CD and DVD drives
 - Hard disk drive
 - Diskette drives and other removable media drives

For the latest information about available options, see the following World Wide Web pages:

- <http://www.lenovo.com/think/en/>
- <http://www.lenovo.com/think/support>

You also can obtain information by calling the following telephone numbers:

- Within the United States, call 1-800-426-2968, your Lenovo reseller, or Lenovo marketing representative.
- Within Canada, call 1-800-565-3344 or 1-800-426-2968.
- Outside the United States and Canada, contact your Lenovo reseller or Lenovo marketing representative.

Tools required

To install some options in your computer, you might need a flat-blade or Phillips screwdriver. Additional tools might be needed for certain options. See the instructions that come with the option.

Handling static-sensitive devices

Static electricity, although harmless to you, can seriously damage computer components and options.

When you add an option, do *not* open the static-protective package containing the option until you are instructed to do so.

When you handle options and other computer components, take these precautions to avoid static electricity damage:

- Limit your movement. Movement can cause static electricity to build up around you.

- Always handle components carefully. Handle adapters and memory modules by the edges. Never touch any exposed circuitry.
- Prevent others from touching components.
- When you install a new option, touch the static-protective package containing the option to a metal expansion-slot cover or other unpainted metal surface on the computer for at least two seconds. This reduces static electricity in the package and your body.
- When possible, remove the option and install it directly in the computer without setting the option down. When this is not possible, place the static-protective package that the option came in on a smooth, level surface and place the option on it.
- Do not place the option on the computer cover or other metal surface.

Installing external options

This section shows the various external connectors on your computer to which you can attach external options, such as external speakers, a printer, or a scanner. For some external options, you must install additional software in addition to making the physical connection. When adding an external option, use the information in this section to identify the required connector, and then use the instructions that come with the option to help you make the connection and install any software or device drivers that are required for the option.

Locating the connectors on the front of your computer

The following illustration shows the locations of the connectors on the front of the computer.

Note: Not all computer models will have the following connectors.

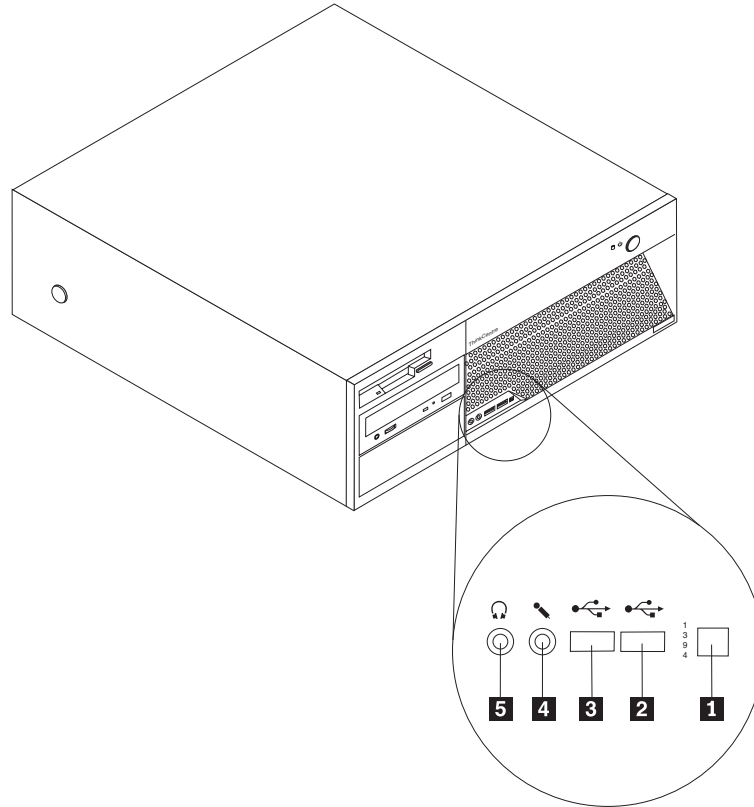

- 1** IEEE 1394 connector
- 2** USB connector
- 3** USB connector

- 4** Microphone connector
- 5** Headphone connector

Locating the connectors on the rear of your computer

The following illustration shows the locations of the connectors on the rear of the computer.

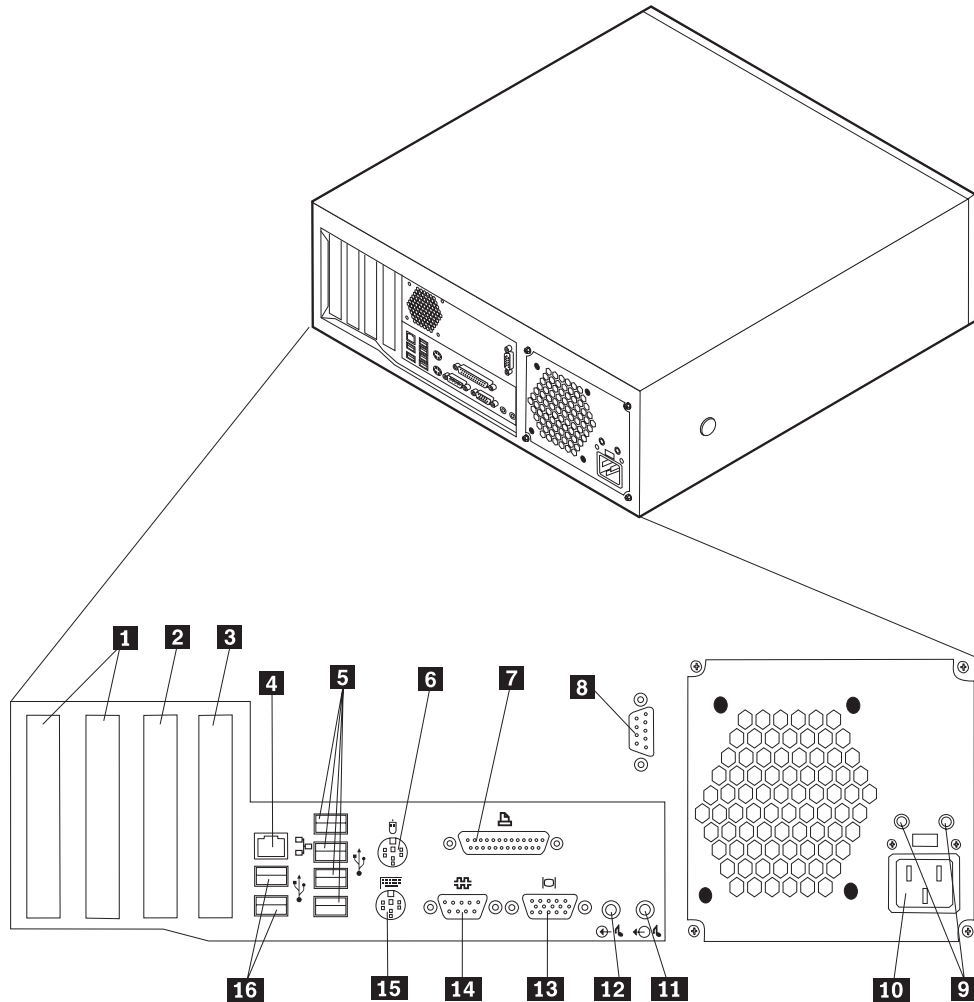

- | | | | |
|----------|--|-----------|--------------------------|
| 1 | PCI adapter connector | 9 | Diagnostic LEDs |
| 2 | PCI Express (x1) adapter connector | 10 | Power connector |
| 3 | PCI Express (x16) graphics adapter connector | 11 | Audio line out connector |
| 4 | Ethernet connector | 12 | Audio line in connector |
| 5 | USB connectors | 13 | VGA monitor connector |
| 6 | Mouse connector | 14 | Serial connector |
| 7 | Parallel connector | 15 | Keyboard connector |
| 8 | Serial connector (some models) | 16 | USB connectors |

Note: Some connectors on the rear of the computer are color-coded to help you determine where to connect the cables on your computer.

Connector	Description
Ethernet connector	Used to attach an Ethernet cable for a local area network (LAN). Note: To operate the computer within FCC Class B limits, use a Category 5 Ethernet cable.
USB connectors	Used to attach a device that requires a Universal Serial Bus (USB) connection, such as a USB scanner or USB printer. If you have more than eight USB devices, you can purchase a USB hub, which you can use to connect additional USB devices.
Mouse connector	Used to attach a mouse, trackball, or other pointing device that uses a standard mouse connector.
Parallel connector	Used to attach a parallel printer, parallel scanner, or other devices that use a 25-pin parallel connector.
Serial connectors	Used to attach an external modem, serial printer, or other devices that use a 9-pin serial connector.
Audio line out connector	Used to send audio signals from the computer to external devices, such as powered stereo speakers (speakers with built-in amplifiers), headphones, multimedia keyboards, or the audio line in connector on a stereo system or other external recording device.
Audio line in connector	Used to receive audio signals from an external audio device, such as a stereo system. When you attach an external audio device, a cable is connected between the audio line out connector of the device and the audio line in connector of the computer.
Keyboard connector	Used to attach a keyboard that uses a standard keyboard connector.

Obtaining device drivers

You can obtain device drivers for operating systems that are not preinstalled at <http://www.lenovo.com/think/support> on the World Wide Web. Installation instructions are provided in README files with the device-driver files.

Removing the cover

Important:

Read “Important safety information” on page v and “Handling static-sensitive devices” on page 5 before removing the computer cover.

To remove the computer cover:

1. Shut down your operating system, remove any media (diskettes, CDs, or tapes) from the drives, and turn off all attached devices and the computer.
2. Unplug all power cords from electrical outlets.
3. Disconnect all cables attached to the computer. This includes power cords, input/output (I/O) cables, and any other cables that are connected to the computer.
4. Press the buttons on the sides of the computer and pivot the rear end of the cover up toward the front of the computer.

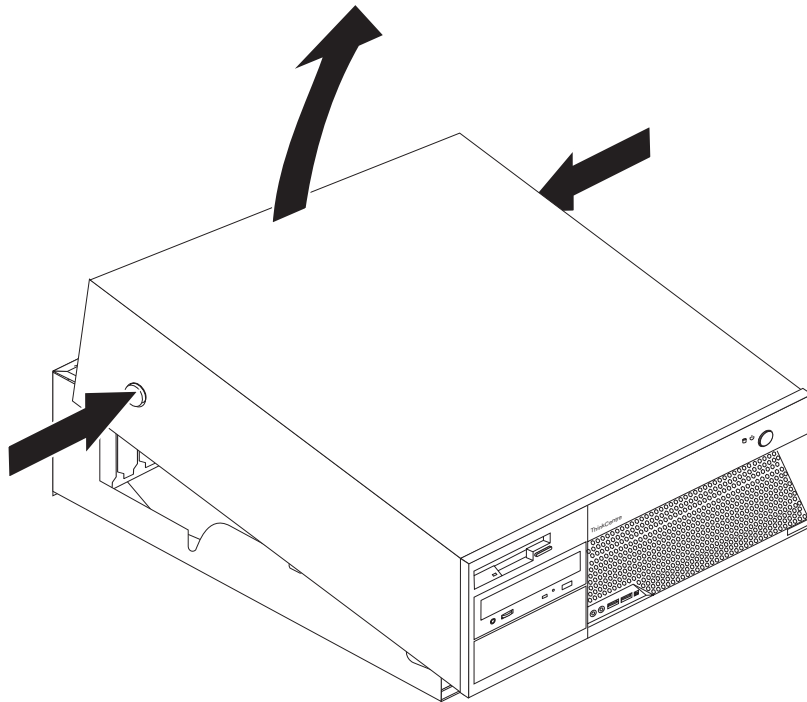

Locating components

The following illustration will help you locate the various components in your computer.

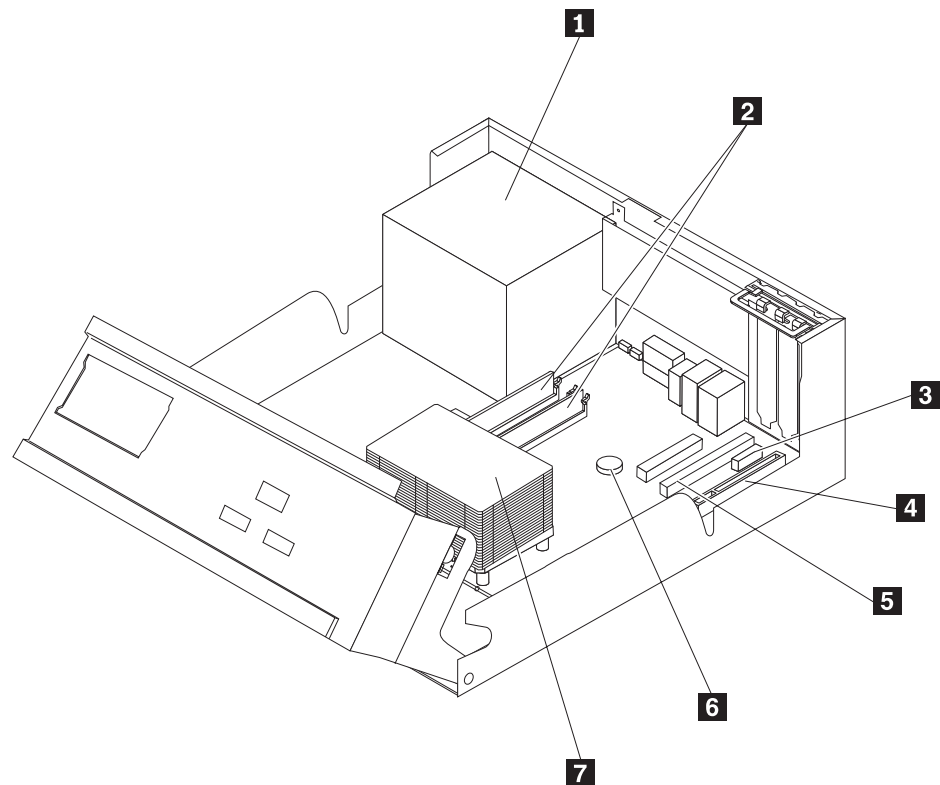

- | | | | |
|----------|------------------------------------|----------|--|
| 1 | Power supply | 5 | PCI Express (x16) graphics adapter connector |
| 2 | Memory modules | 6 | Battery |
| 3 | PCI Express (x1) adapter connector | 7 | Microprocessor and heat sink |
| 4 | PCI adapter connector | | |

Identifying parts on the system board

The system board (sometimes called the *planar* or *motherboard*) is the main circuit board in your computer. It provides basic computer functions and supports a variety of devices that are factory-installed or that you can install later.

The following illustration shows the locations of parts on the system board.

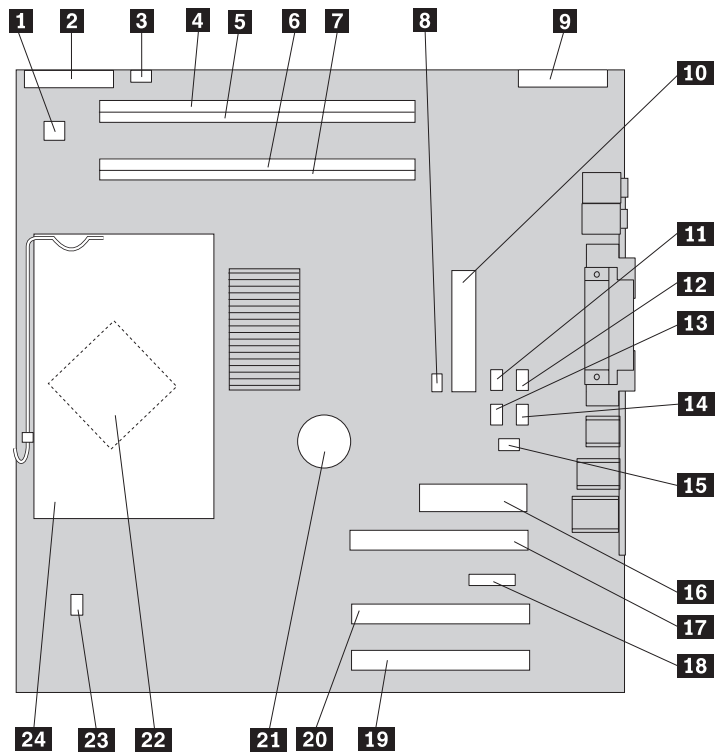

- | | | | |
|-----------|----------------------------|-----------|--|
| 1 | 12v power connector | 13 | SATA 2 connector |
| 2 | Diskette drive connector | 14 | SATA 1 connector |
| 3 | Speaker connector | 15 | Cover presence switch connector |
| 4 | Memory connector 4 | 16 | Power supply connector |
| 5 | Memory connector 3 | 17 | PCI Express (x16) graphics adapter connector |
| 6 | Memory connector 2 | 18 | PCI Express (x1) adapter connector |
| 7 | Memory connector 1 | 19 | PCI adapter connector 2 |
| 8 | Clear CMOS/Recovery jumper | 20 | PCI adapter connector 1 |
| 9 | Front panel connector | 21 | Battery |
| 10 | PATA IDE connector | 22 | Microprocessor |
| 11 | SATA 4 connector | 23 | Microprocessor fan connector |
| 12 | SATA 3 connector | 24 | Microprocessor heat sink |

Installing memory

Your computer has four connectors for installing dual inline memory modules (DIMMs) that provide up to a maximum of 4.0 GB of system memory.

Note: Addressable memory might be less than total supported memory.

System memory is divided into two channels (channel A and B). Memory connectors 1 and 2 are channel A, and memory connectors 3 and 4 are channel B. If memory modules are present in both channels, your computer operates in dual channel mode.

Your computer has either double data rate (DDR) or double data rate 2 (DDR2) memory. The type of memory required depends on the system board that is installed in your computer.

1. Remove the computer cover. See "Removing the cover" on page 10.
2. Locate the memory connectors. See "Identifying parts on the system board" on page 11.
 - If the two memory connectors closest to the edge of the system board are a yellow color, your system board has DDR type memory. DDR memory modules are 184-pin, 2.5 V and can be used in any combination of 128 MB, 256 MB, 512 MB, and 1 GB sizes.
 - If the two memory connectors closest to the edge of the system board are a green color, your system board has DDR2 type memory. DDR2 memory modules are 240-pin, 1.8 V and can be used in any combination of 256 MB, 512 MB, and 1 GB sizes.

Notes:

- a. The type of memory required is also indicated in text near the logo on the system board.
- b. System memory as reported in the "System Summary" section of the Setup Utility or the operating system might be less than the amount of physical memory installed. This discrepancy is due to memory addressing limitations of the Intel 915G Family chipset, and is usually not visible until more than 3.0 GB of memory is installed.

To install a memory module:

1. Remove the computer cover. See "Removing the cover" on page 10.
2. Pivot the drive bay assembly upward to gain access to the system board.

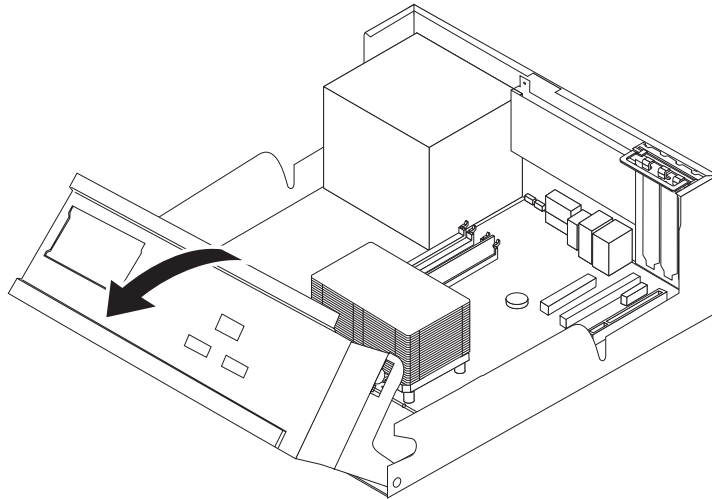

3. Locate the memory connectors. See "Identifying parts on the system board" on page 11.
4. Open the retaining clips.

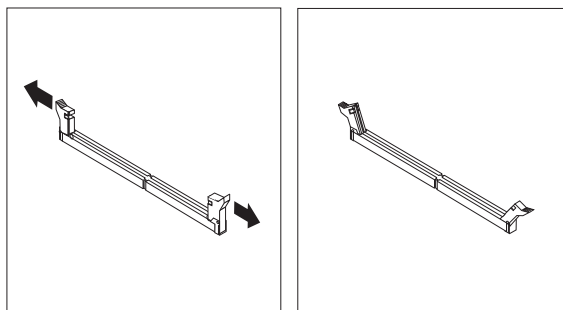

5. Position the memory module over the memory connector. Make sure that the notch **1** on the memory module aligns correctly with the connector key **2** on the system board. Push the memory module straight down into the memory connector until the retaining clips close.

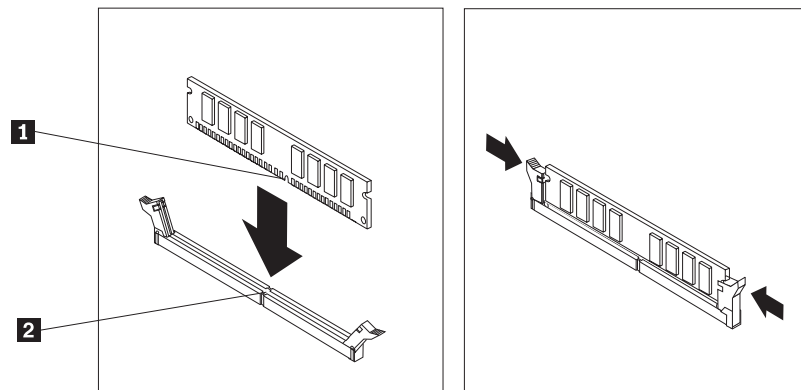

What to do next:

- To work with another option, go to the appropriate section.
- To complete the installation, go to “Replacing the cover and connecting the cables” on page 23.

Installing adapters

This section provides information and instructions for installing and removing adapters. Your computer has two expansion connectors for PCI adapters, one PCI Express (x1) adapter connector, and one PCI Express (x16) graphics adapter connector. You can install an adapter up to 340 mm (13.4 inches) long in PCI adapter connector 1 and PCI adapter connector 2.

To install an adapter:

1. Remove the computer cover. See “Removing the cover” on page 10.
2. Pivot the drive bay assembly upward to gain access to the system board.

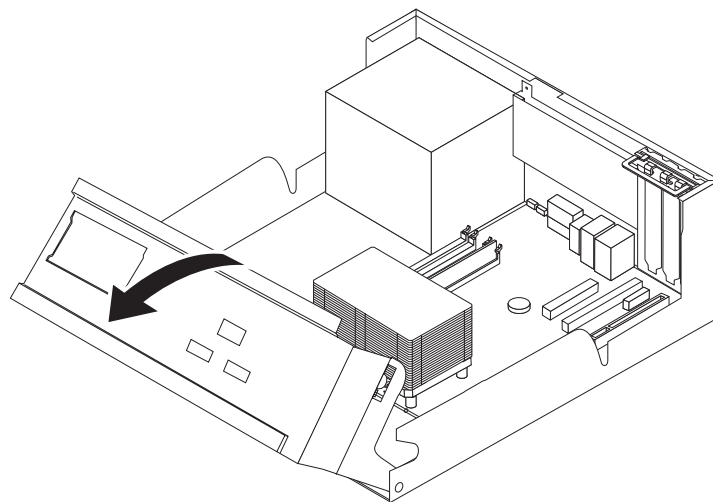

3. Open the adapter latch and remove the connector cover for the appropriate expansion connector.

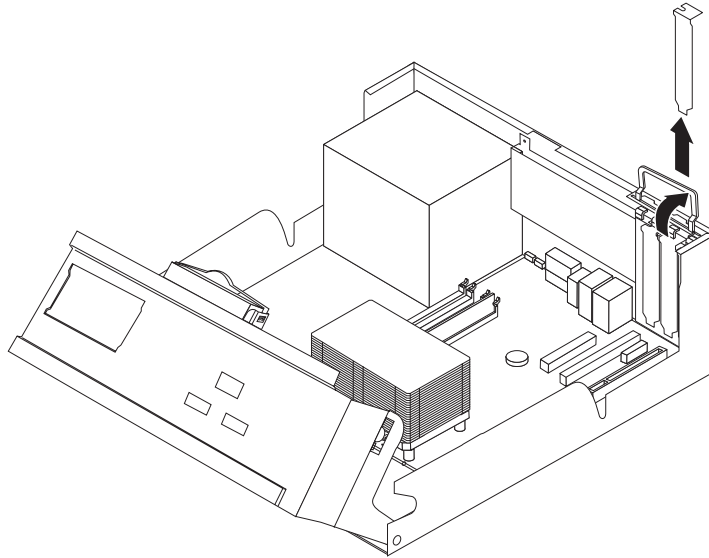

4. Remove the adapter from its static-protective package.
5. Install the adapter into the appropriate connector on the system board.
6. Close the adapter latch to secure the adapter.

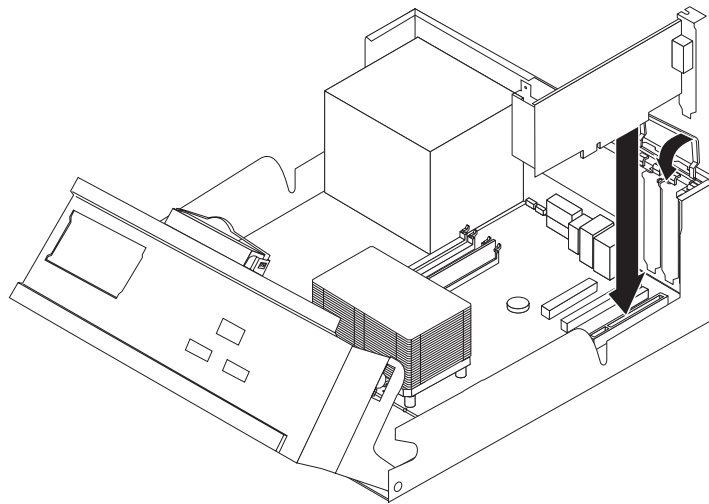

What to do next:

- To work with another option, go to the appropriate section.
- To complete the installation, go to “Replacing the cover and connecting the cables” on page 23.

Installing internal drives

This section provides information and instructions for installing and removing internal drives.

Internal drives are devices that your computer uses to read and store data. You can add drives to your computer to increase storage capacity and to enable your computer to read other types of media. Some of the different drives that are available for your computer are:

- Serial Advanced Technology Attachment (SATA) hard disk drives
- Parallel ATA hard disk drives
- Optical drives such as CD, CD-RW, and DVD drives
- Tape drives
- Removable media drives

Note: These different drives are also referred to as integrated drive electronics (IDE) drives.

Internal drives are installed in *bays*. In this book, the bays are referred to as bay 1, bay 2, and so on.

When you install an internal drive, it is important to note what type and size of drive that you can install in each bay. Also, it is important to correctly connect the internal drive cables to the installed drive.

Drive specifications

Your computer comes with the following factory-installed drives:

- A 3.5-inch diskette drive in bay 1 (some models)
- An optical drive in bay 2 (some models)
- A 3.5-inch hard disk drive in bay 4

Any bay that does not have a drive installed has a static shield and bay panel installed.

The following illustration shows the locations of the drive bays.

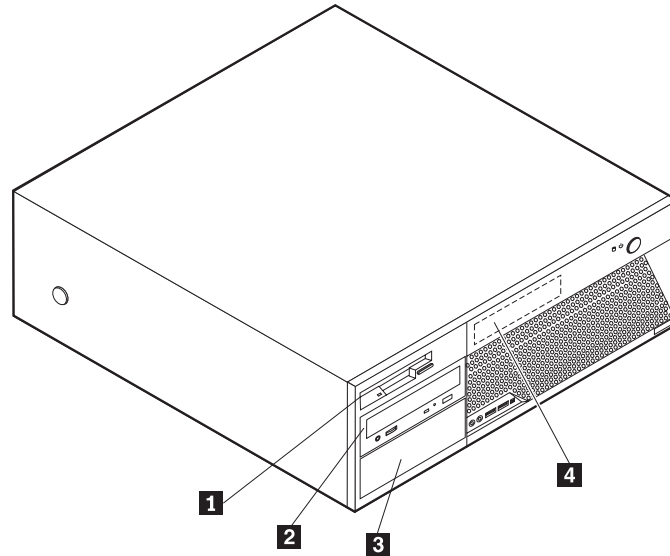

The following list describes some of the drives that you can install in each bay and their height requirements:

- | | |
|--|---|
| 1 Bay 1 - Maximum height: 25.8 mm (1.0 in.) | 3.5-inch diskette drive (preinstalled in some models) |
| 2 Bay 2 - Maximum height: 43.0 mm (1.7 in.) | <ul style="list-style-type: none">• Optical drive such as CD drive or DVD drive (preinstalled in some models)• 3.5-inch hard disk drive (requires a Universal Adapter Bracket, 5.25 to 3.5-inch) * |
| 3 Bay 3 - Maximum height: 43.0 mm (1.7 in.) | <ul style="list-style-type: none">• 5.25-inch removable media drive• Optical drive such as CD drive or DVD drive• 3.5-inch hard disk drive (requires a Universal Adapter Bracket, 5.25 to 3.5-inch) * |
| 4 Bay 4 - Maximum height: 25.8 mm (1.0 in.) | 3.5-inch hard disk drive (preinstalled) |
- * You can obtain a Universal Adapter Bracket, 5.25 to 3.5-inch, from a local computer retailer or by contacting the Customer Support Center.

Notes:

1. Drives that are greater than 43.0 mm (1.7 in.) high cannot be installed.
2. Install removable media (tape or CD) drives in an accessible bay (bay 2 or 3).

Installing a drive

To install an internal drive, follow these steps:

1. Remove the computer cover. See "Removing the cover" on page 10.
2. If your computer has an optical drive, you might need to remove the signal and power cables from the drive.
3. If the drive you are installing is a removable-media drive, remove the bay panel from the front bezel.

4. Remove the metal shield from the drive bay by inserting a flat-blade screwdriver into one of the slots and gently prying it loose.

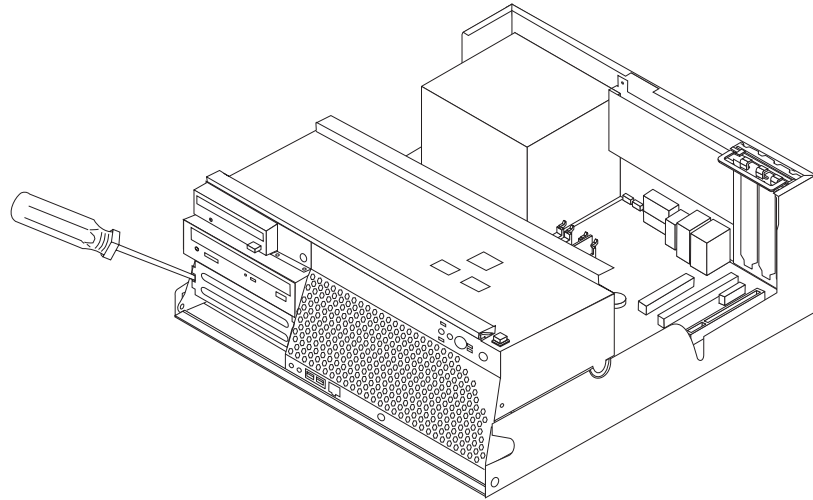

5. If you are installing any type of drive other than a serial ATA hard disk drive, make sure the drive that you are installing is set correctly as either a master or a slave device.

Note: A serial ATA hard disk drive does not need to be set as either a master or a slave device.

- If it is the first optical drive, set it as a master device.
- If it is an additional optical drive, set it as a slave device.
- If it is an additional parallel ATA hard disk drive, set it as a slave device.

Refer to the documentation that comes with your drive for master/slave jumper information.

6. For a 5.25-inch drive, install a retainer bracket on the side of the drive.

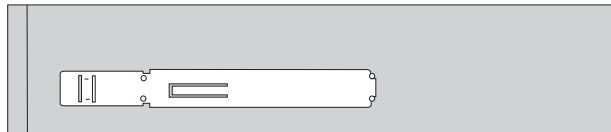

7. For a 3.5-inch drive, install the drive into the Universal Adapter Bracket, 5.25 to 3.5-inch.

8. Install the drive into the bay until it snaps into position.

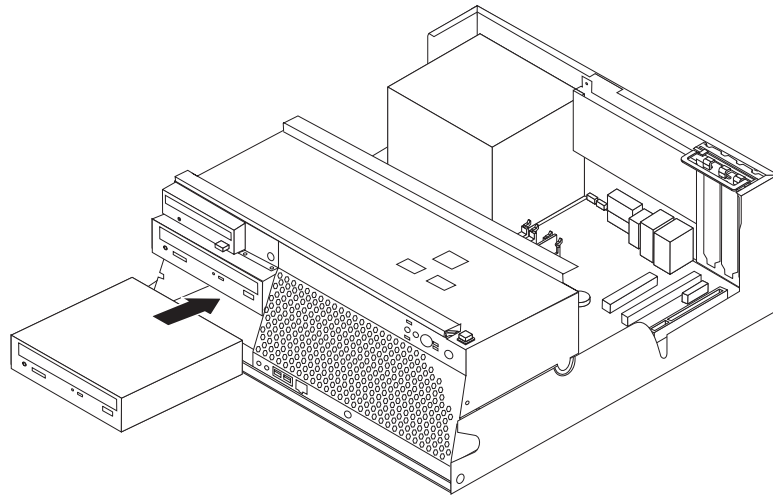

9. A drive requires two cables; a power cable that connects to the power supply and a signal cable that connects to the system board.
 - A parallel ATA hard disk drive or optical drive requires a four-wire power cable.

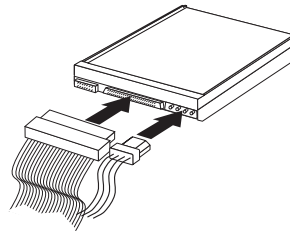

- A serial ATA hard disk drive requires a five-wire power cable.

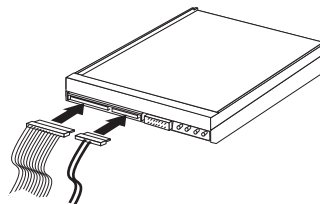

The steps to connect a drive are different depending on the type of drive you are connecting. Use one of the following procedures for your drive connection.

Connecting the first optical drive

1. Locate the three-connector signal cable that comes with your computer or with the new drive.
2. Locate the PATA IDE connector on the system board. See “Identifying parts on the system board” on page 11.
3. Connect one end of the signal cable to the drive and the other to the PATA IDE connector on the system board. To reduce electronic noise, use the connectors at the end of the cable only.
4. Your computer has extra power connectors for additional drives. Connect a power connector to the drive.

Connecting an additional optical drive or parallel ATA hard disk drive

1. Locate the PATA IDE connector on the system board and the three-connector signal cable. See “Identifying parts on the system board” on page 11.
2. Connect the extra connector on the signal cable to the new drive.
3. Your computer has extra power connectors for additional drives. Connect a power connector to the drive.

Connecting a serial ATA hard disk drive

A serial hard disk drive can be connected to any available SATA connector.

1. Locate the signal cable that comes with the new drive.
2. Locate an available SATA connector on the system board. See “Identifying parts on the system board” on page 11.
3. Connect one end of the signal cable to the drive and the other to an available SATA connector on the system board.
4. Your computer has extra power connectors for additional drives. Connect a power connector to the drive.

What to do next

- To work with another option, go to the appropriate section.
- To complete the installation, go to “Replacing the cover and connecting the cables” on page 23.

Installing security features

To help prevent hardware theft and unauthorized access to your computer, security lock options are available. In addition to physical locks, unauthorized use of your computer can be prevented by a software lock that locks the keyboard until a correct password is typed in.

Padlock loop

Your computer is equipped with a padlock loop that locks the cover to your computer when a padlock is installed.

Make sure that the padlock loop does not interfere with the computer cables.

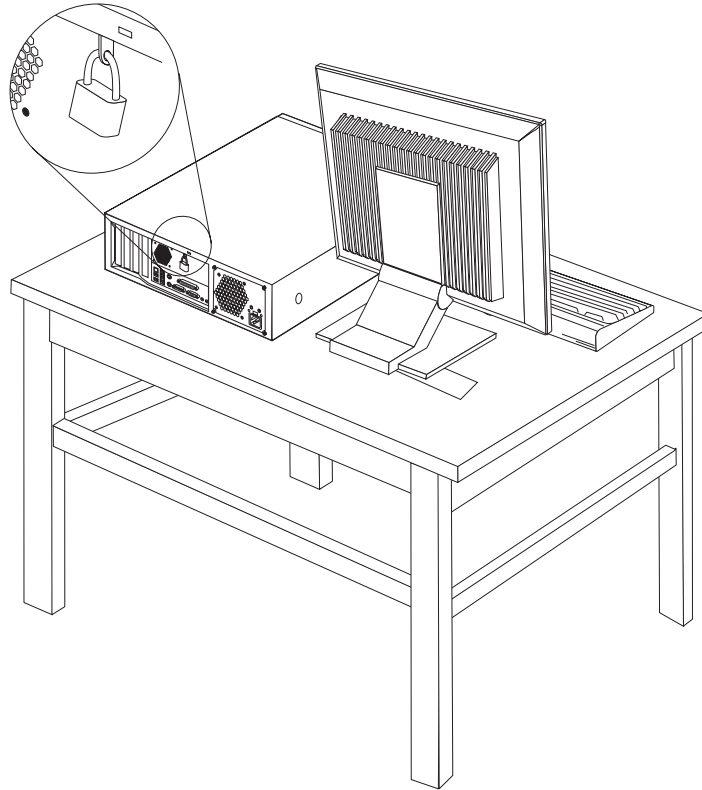

Password protection

To deter unauthorized use of your computer, you can use the Setup Utility program to set a password. See “Using passwords” on page 25.

What to do next:

- To work with another option, go to the appropriate section.
- To complete the installation, go to “Replacing the cover and connecting the cables” on page 23.

Changing the battery

Your computer has a special type of memory that maintains the date, time, and settings for built-in features, such as parallel-port assignments (configuration). A battery keeps this information active when you turn off the computer.

The battery normally requires no charging or maintenance throughout its life; however, no battery lasts forever. If the battery fails, the date, time, and configuration information (including passwords) are lost. An error message is displayed when you turn on the computer.

Refer to “Lithium battery notice” on page x for information about replacing and disposing of the battery.

To change the battery:

1. Remove the computer cover. See “Removing the cover” on page 10.
2. Pivot the drive bay assembly upward to gain access to the system board.

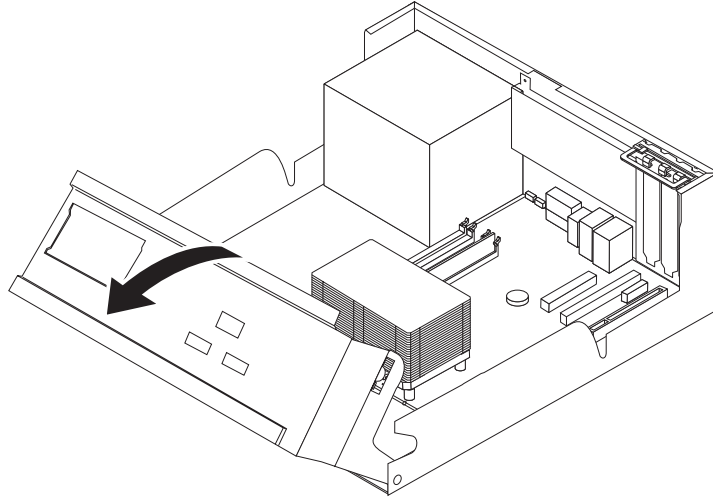

3. Locate the battery. See “Identifying parts on the system board” on page 11.
4. If necessary, remove any adapters that impede access to the battery. See “Installing adapters” on page 14 for more information.
5. Remove the old battery.

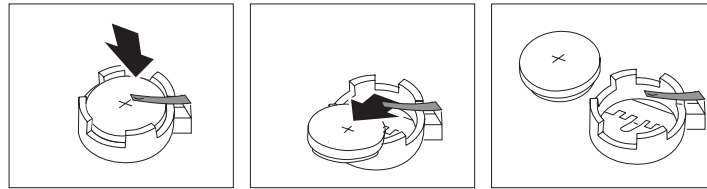

6. Install the new battery.

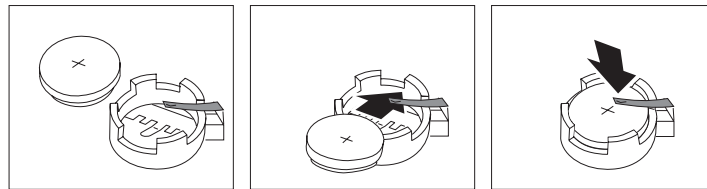

7. Replace any adapters that were removed to gain access to the battery. See “Installing adapters” on page 14 for instructions for replacing adapters.
8. Replace the computer cover, and plug in the power cord. See “Replacing the cover and connecting the cables” on page 23.

Note: When the computer is turned on for the first time after battery replacement, an error message might be displayed. This is normal after replacing the battery.

9. Turn on the computer and all attached devices.
10. Use the Setup Utility program to set the date and time and any passwords. See Chapter 2, “Using the Setup Utility program,” on page 25.

Erasing a lost or forgotten password (clearing CMOS)

This section applies to lost or forgotten passwords. For more information about lost or forgotten passwords, see the Access IBM program on your desktop.

To erase a forgotten password:

1. Remove the computer cover. See “Removing the cover” on page 10.
2. Pivot the drive bay assembly upward to gain access to the system board.

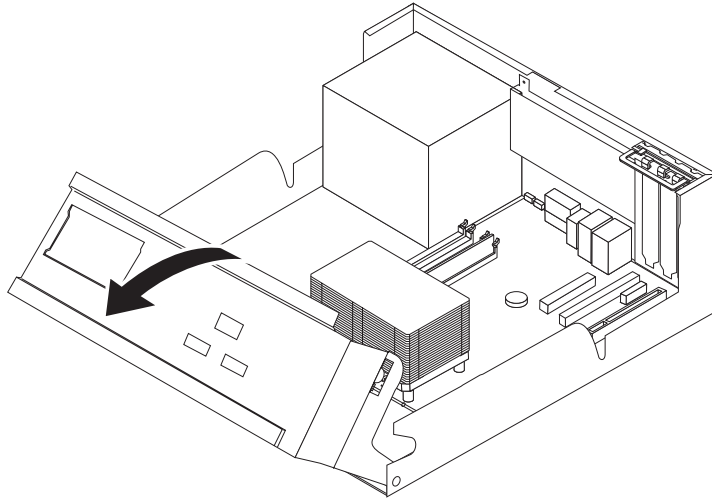

3. Locate the Clear CMOS/Recovery jumper on the system board. See “Identifying parts on the system board” on page 11.
4. If necessary, see “Installing adapters” on page 14 to remove any adapters that impede access to the Clear CMOS/Recovery jumper.
5. Move the jumper from the standard position (pins 1 and 2) to the maintenance or configure position (pins 2 and 3).
6. Replace the computer cover and connect the power cord. See “Replacing the cover and connecting the cables.”
7. Restart the computer, leave it on for approximately 10 seconds. Turn off the computer by holding the power switch for approximately 5 seconds. The computer will turn off.
8. Repeat steps 1 through 4 on page 23.
9. Move the jumper back to the standard (pins 1 and 2).
10. Replace the computer cover and connect the power cord. See “Replacing the cover and connecting the cables.”

Replacing the cover and connecting the cables

After working with options, you need to install any removed parts, replace the computer cover, and reconnect any cables, including telephone lines and power cords. Also, depending on the option that is installed, you might need to confirm the updated information in the Setup Utility program.

To replace the computer cover and connect cables to your computer:

1. Ensure that all components have been reassembled correctly and that no tools or loose screws are left inside your computer.
2. Lower the drive bay assembly.
3. Clear any cables that might impede the replacement of the computer cover.

4. Position the cover over the chassis and pivot it down over the computer until it snaps into place.

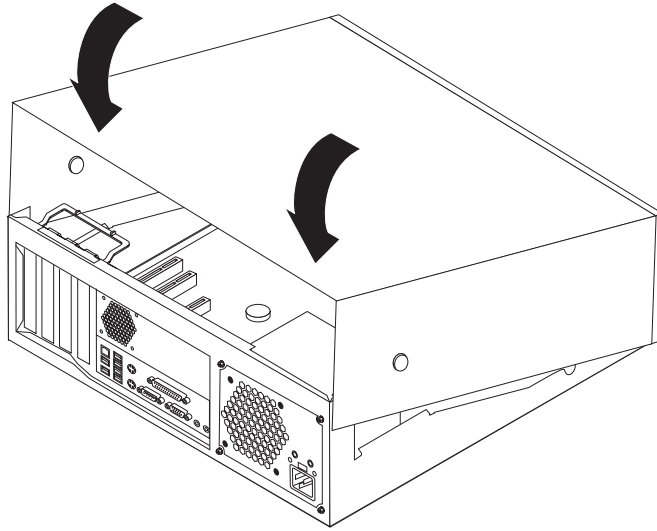

5. Reconnect the external cables and power cords to the computer. See “Installing external options” on page 6.
6. To update the configuration, see Chapter 2, “Using the Setup Utility program,” on page 25.

Chapter 2. Using the Setup Utility program

The Setup Utility program is stored in the electrically erasable programmable read-only memory (EEPROM) of your computer. The Setup Utility program is used to view and change the configuration settings of your computer, regardless of which operating system you are using. However, the operating-system settings might override any similar settings in the Setup Utility program.

Starting the Setup Utility program

To start the Setup Utility program, do the following:

1. If your computer is already on when you start this procedure, shut down the operating system and turn off the computer.
2. Press and hold the F1 key then turn on the computer. When you hear the multiple beeps, release the F1 key.

Notes:

- a. If you are using a USB keyboard and the Setup Utility program does not display using this method, press and release the F1 key repeatedly rather than leaving it pressed when turning on the computer.
- b. If a user password or an administrator password has been set, the Setup Utility program menu is not displayed until you type your password. See “Using passwords” for more information.

The Setup Utility might start automatically when POST detects that hardware has been removed or new hardware has been installed in your computer.

Viewing and changing settings

The Setup Utility program menu lists items that identify system configuration topics.

When working with the Setup Utility program menu, you must use the keyboard. The keys used to perform various tasks are displayed at the bottom of each screen.

Using passwords

By using the Setup Utility program, you can set passwords to prevent unauthorized persons from gaining access to your computer and data. The following types of passwords are available:

- User Password
- Administrator Password
- IDE Drive User Password
- IDE Drive Master Password

You do not have to set any passwords to use your computer. However, if you decide to set any passwords, read the following sections.

Password considerations

If you are setting any of the various types of passwords on your computer, you should read and understand the following information:

- If you type an incorrect password, you will see an error message. If you type an incorrect password three consecutive times, you must turn the computer off and start again.
- If you set both a User Password and an IDE Drive User Password and each password is the same, you will be prompted for the password only once when you turn on your computer.
- Do not move an IDE hard disk drive to another computer if an IDE Drive User Password has been set unless that computer also supports the IDE Drive User password.
- If your computer is connected to a local area network (LAN), the Wake on LAN feature will not work unless both a User Password and an IDE Drive User Password are set using the same password.

User password

When a User Password is set, the user is prompted to type a valid password each time the computer is turned on. The computer cannot be used until a valid password is typed from the keyboard.

Administrator password

Setting an Administrator Password deters unauthorized persons from changing configuration settings. If you are responsible for maintaining the settings of several computers, you might want to set an Administrator Password.

After you set an Administrator Password, a password prompt is displayed each time you try to access the Setup Utility program.

If both the user and administrator passwords are set, you can type either password. However, to change any configuration settings, you must use your administrator password.

IDE Drive User Password

The IDE Drive User Password is used to protect the data on the IDE hard disk drive(s). When this password is set, you are prompted to type a valid password before any hard disk drive can be used. This prompt is displayed each time you turn on your computer. If your computer has multiple hard disk drives, they all must use the same password.

Attention

If an IDE Drive User Password is set but no IDE Drive Master Password is set, there is no recovery in the event that the IDE Drive User Password is lost or forgotten. The hard disk drive must be replaced. See “IDE Drive Master Password.”

IDE Drive Master Password

The IDE Drive Master Password is used to recover use of the hard disk drive in the event that the IDE Drive User Password is lost or forgotten. Only the person who knows the IDE Drive Master password can reset the IDE Drive User Password.

Attention

Make sure that the IDE Drive Master password is stored in a safe place. If both the IDE Drive User password and the IDE Drive Master password are lost or forgotten, the IDE hard disk drive must be replaced.

If both the IDE Drive User Password and the IDE Drive Master Password are to be set, the IDE Drive Master Password must be set before setting the IDE Drive User Password.

Setting, changing, and deleting a password

To set, change, or delete a password, do the following:

Note: A password can be any combination of up to seven characters (A- Z, a-z, and 0-9).

1. Start the Setup Utility program (see “Starting the Setup Utility program” on page 25).
2. From the Setup Utility program menu, select **Security**.
3. Select **Set Passwords**. Read the information displayed on the right side of the screen.

Using Security Profile by Device

Security Profile by Device is used to enable or disable user access to the following devices:

IDE controller	When this feature is set to Disable , all devices connected to the IDE controller (such as hard disk drives or the CD-ROM drive) are disabled and will not be displayed in the system configuration.
Diskette Drive Access	When this feature is set to Disable , the diskette drive cannot be accessed.
Diskette Write Protect	When this feature is set to Enable , all diskettes are treated as if they are write-protected. You can read the diskette, but you cannot write to the diskette.

To set Security Profile by Device, do the following:

1. Start the Setup Utility program (see “Starting the Setup Utility program” on page 25).
2. From the Setup Utility program menu, select **Security**.
3. Select **Security Profile by Device**.
4. Select the desired devices and settings and press Enter.
5. Return to the Setup Utility program menu and select **Exit** and then **Save Settings**.

Selecting a startup device

If your computer does not start up (boot) from a device such as the CD-ROM, diskette, or hard disk as expected, use one of the following procedures to select a startup device.

Selecting a temporary startup device

Use this procedure to startup from any boot device.

Note: Not all CDs, hard disks, and diskettes are startable (bootable).

1. Turn off your computer.
2. Press and hold the F12 key then turn on your computer. When the Startup Device Menu displays, release the F12 key.

Note: If you are using a USB keyboard and the Startup Device Menu does not display using this method, press and release the F12 key repeatedly rather than leaving it pressed when turning on the computer.

3. Select the desired startup device from the Startup Device Menu and press Enter to begin.

Note: Selecting a startup device from the Startup Device Menu does not permanently change the startup sequence.

Changing the startup sequence

To view or change the primary or automatic power-on startup sequence, do the following:

1. Start the Setup Utility program (see “Starting the Setup Utility program” on page 25).
2. Select **Startup**.
3. Select **Startup Sequence**. See the information displayed on the right side of the screen.
4. Select the sequence of devices for the Primary Startup Sequence, the Automatic Startup Sequence, and the Error Startup Sequence.
5. Select **Exit** from the Setup Utility menu and then **Save Settings**.

If you have changed these settings and want to return to the default settings, select **Load Default Settings** on the Exit menu.

Exiting from the Setup Utility program

When you finish viewing or changing settings, press Esc to return to the Setup Utility program menu (you might have to press Esc several times). If you want to save the new settings, select **Save Settings** before you exit. Otherwise, your changes will not be saved.

Appendix A. Updating system programs

This appendix contains information about updating system programs and how to recover from a POST/BIOS update failure.

System programs

System programs are the basic layer of software that is built into your computer. They include the power-on self-test (POST), the basic input/output system (BIOS) code, and the Setup Utility program. POST is a set of tests and procedures that is performed each time you turn on your computer. BIOS is a layer of software that translates instructions from other layers of software into electrical signals that the computer hardware can understand. You can use the Setup Utility program to view and change the configuration and setup of your computer.

Your computer system board has a module called *electrically erasable programmable read-only memory* (EEPROM, also referred to as *flash memory*). You can easily update POST, BIOS, and the Setup Utility program by starting your computer using a flash update diskette or by running a special update program from your operating system.

Lenovo might make changes and enhancements to the system programs. When updates are released, they are available as downloadable files on the World Wide Web (see the *Quick Reference*). Instructions for using the system program updates are available in a .txt file that is included with the update files. For most models, you can download either an update program to create a system-program-update (flash) diskette or an update program that can be run from the operating system.

Updating (flashing) BIOS from a diskette

1. Insert a system program update (flash) diskette into the diskette drive (drive A) in your computer. System program updates are available at <http://www.lenovo.com/think/support> on the World Wide Web.
2. Turn on the computer. If it is on already, you must turn it off and back on again. The update begins.
3. When you are prompted to select a language, press the number on your keyboard which corresponds to the language then press Enter.
4. When prompted to change the serial number, press Y.
5. Type in the seven character serial number of your computer then press Enter.
6. When prompted to change the machine type/model, press Y.
7. Type in the seven character machine type/model of your computer then press Enter.
8. Follow the instructions on the screen to complete the update.

Updating (flashing) BIOS from your operating system

Note: Due to constant improvements being made to the Web site, Web page content (including the links referenced in the following procedure) is subject to change.

1. From your browser, type <http://www.lenovo.com/think/support> in the address field and press Enter.

2. Locate the Downloadable files for your machine type as follows:
 - a. Under Use Quick path, type your machine type and click **Go**.
 - b. Click **Continue**.
 - c. Click **Downloads and drivers**.
 - d. Under the BIOS category, click the Flash BIOS update.
 - e. Click the .txt file that contains the installation instructions for the flash BIOS update (flash from the operating system version).
3. Print these instructions. This is very important since they are not on the screen after the download begins.
4. From your browser, click **Back** to return to the list of files. Carefully follow the printed instructions to download, extract, and install the update.

Recovering from a POST/BIOS update failure

If power to your computer is interrupted while POST/BIOS is being updated (flash update), your computer might not restart correctly. If this happens, perform the following procedure (also known as a Boot-block Recovery):

1. Turn off the computer and any attached devices, such as printers, monitors, and external drives.
2. Unplug all power cords from electrical outlets, and remove the computer cover. See "Removing the cover" on page 10.
3. Pivot the drive bay assembly upward to gain access to the system board.
4. Locate the Clear CMOS/Recovery jumper on the system board. See "Identifying parts on the system board" on page 11.
5. If necessary, refer to Installing adapters to remove any adapters that impede access to the Clear CMOS/Recovery jumper.
6. Move the jumper from the standard position (pins 1 and 2) to pins 2 and 3.
7. Replace the computer cover. See "Replacing the cover and connecting the cables" on page 23.
8. Reconnect the power cords for the computer and monitor to electrical outlets.
9. Insert the POST/BIOS update (flash) diskette into drive A, and turn on the computer and the monitor.
10. The recovery session will take two to three minutes. During this time you will hear a series of beeps. After the update session is completed, there will be no video, the series of beeps will end, and the system will automatically turn off. Remove the diskette from the diskette drive.
11. Repeats steps 2 through 5 on page 30.
12. Replace the Clear CMOS/Recovery jumper to its original position.
13. Replace any adapters that were removed.
14. Replace the computer cover and reconnect any cables that were disconnected. See "Replacing the cover and connecting the cables" on page 23.
15. Turn on the computer to restart the operating system.

Appendix B. Cleaning the mouse

This appendix provides instructions on how to clean your mouse. The procedure will be different depending on which type of mouse you have.

Cleaning an optical mouse

If you experience some problems with your optical mouse, check the following:

1. Turn the mouse over and look carefully at the lens area.
 - a. If there is a smudge on the lens, gently clean the area with a plain cotton-tipped swab.
 - b. If there is some debris in the lens, gently blow the debris away from the area.
2. Check the surface on which you are using the mouse. If you have a very intricate picture or pattern beneath the mouse it is difficult for the digital signal processor (DSP) to determine changes in the mouse position.

Cleaning a mouse with a ball

If the pointer on the screen does not move smoothly with the mouse, you might need to clean the mouse.

Note: The following illustration might be slightly different from your mouse.

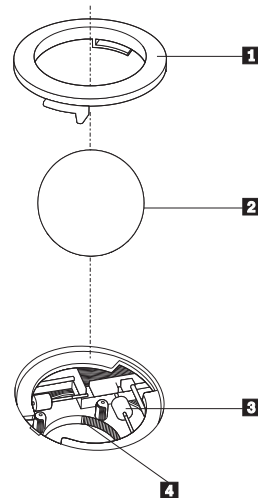

- 1** Retainer ring
- 2** Ball
- 3** Plastic rollers
- 4** Ball cage

To clean a mouse with a ball:

1. Turn off your computer.
2. Turn the mouse over, with the top side down, and look carefully at the bottom. Twist the retainer ring **1** to the unlocked position to remove the ball.
3. Place your hand over the retainer ring and ball **2**, and then turn the mouse over, top side up, so that the retainer ring and ball fall out into your hand.
4. Wash the ball in warm, soapy water then dry it with a clean cloth. Blow air carefully into the ball cage **4** to dislodge dust and lint.
5. Look for a build up of dirt on the plastic rollers **3** inside the ball cage. This build up usually appears as a stripe running across the middle of the rollers.
6. If the rollers are dirty, clean them by using a cotton swab soaked in isopropyl (rubbing) alcohol. Turn the rollers with your finger and continue swabbing them until all the dirt is removed. Be sure the rollers are still centered in their channels after you clean them.
7. Remove any fibers from the swab that might be remaining on the rollers.
8. Replace the ball and the retainer ring.
9. Turn your computer back on.

Appendix C. Manual modem commands

The following section lists commands for manually programming your modem.

Commands are accepted by the modem while it is in Command Mode. Your modem is automatically in Command Mode until you dial a number and establish a connection. Commands can be sent to your modem from a PC running communication software or any other terminal devices.

All commands sent to the modem must begin with **AT** and end with **ENTER**. All commands can be typed in either upper or lower case, but not mixed. To make the command line more readable, spaces can be inserted between commands. If you omit a parameter from a command that requires one, it is just like specifying a parameter of **0**.

Example:

ATH [ENTER]

Basic AT commands

In the following listings, all default settings are printed in **bold text**.

Command		Function
A		Manually answer incoming call.
A/		Repeat last command executed. Do not precede A/ with AT or follow with ENTER.
D_		0 - 9, A-D, # and *
	L	last number redial
	P	pulse dialing
		Note: Pulse dialing is not supported for Australia, New Zealand, Norway, and South Africa.
	T	touch-tone dialing
	W	wait for second dial tone
	,	pause
	@	wait for five seconds of silence
	!	flash
	;	return to Command Mode after dialing
DS=n		Dial one of the four telephone numbers (n=0-3) stored in the modem non-volatile memory.
E_	E0	Commands are not echoed
	E1	Commands are echoed
+++		Escape Characters - Switch from Data Mode to Command Mode (T.I.E.S. Command)
H_	H0	Force modem on-hook (hang up)

Command		Function
	H1	Force modem off-hook (make busy) Note: H1 command is not supported for Italy
I_	I0	Display product-identification code
	I1	Factory ROM checksum test
	I2	Internal memory test
	I3	Firmware ID
	I4	Reserved ID
L_	L0	Low speaker volume
	L1	Low speaker volume
	L2	Medium speaker volume
	L3	High speaker volume
M_	M0	Internal speaker off
	M1	Internal speaker on until carrier detected
	M2	Internal speaker always on
	M3	Internal speaker on until carrier detected and off while dialing
N_		Included for compatibility only, provides no effect
O_	O0	Return to Data Mode
	O1	Return to Data Mode and initiate an equalizer retrain
P		Set Pulse dial as default
Q_	Q0	Modem sends responses
Sr?		Read and display value in register r.
Sr=n		Set register r to value n (n = 0-255).
T		Set Tone Dial as default
V_	V0	Numeric responses
	V1	Word responses
W_	W0	Report DTE speed only
	W1	Report line speed, error correction protocol, and DTE speed.
	W2	Report DCE speed only
X_	X0	Hayes Smartmodem 300 compatible responses/blind dialing.
	X1	Same as X0 plus all CONNECT responses/blind dialing
	X2	Same as X1 plus dial tone detection
	X3	Same as X1 plus busy detection/blind dialing
	X4	All responses and dial tone and busy signal detection
Z_	Z0	Reset and retrieve active profile 0
	Z1	Reset and retrieve active profile 1

Extended AT commands

Command		Function
&C_	&C0	Force Carrier Detect Signal High (ON)
	&C1	Turn on CD when remote carrier is present
&D_	&D0	Modem ignores the DTR signal
	&D1	Modem returns to Command Mode after DTR toggle
	&D2	Modem hangs up, returns to the Command Mode after DTR toggle
	&D3	Resets modem after DTR toggle
&F_	&F	Recall factory default configuration
&G_	&G0	Guard tone disabled
	&G1	Guard tone disabled
	&G2	1800 Hz guard tone
&K_	&K0	Disable flow control
	&K3	Enable RTS/CTS hardware flow control
	&K4	Enable XON/XOFF software flow control
	&K5	Enable transparent XON/XOFF flow control
	&K6	Enable both RTS/CTS and XON/XOFF flow control
&M_	&M0	Asynchronous operation
&P_	&P0	US setting for off-hook-to-on-hook ratio
	&P1	UK and Hong Kong off-hook-to-on-hook ratio
	&P2	Same as &P0 setting but at 20 pulses per minute
	&P3	Same as &P1 setting but at 20 pulses per minute
&R_	&R0	Reserved
	&R1	CTS operates per flow control requirements
&S_	&S0	Force DSR Signal High (ON)
	&S1	DSR off in command mode, on in on-line mode
&T_	&T0	Ends test in progress
	&T1	Perform Local Analog Loopback Test
	&T3	Perform Local Digital Loopback Test
	&T4	Grant Remote Digital Loopback Test request by remote modem
	&T5	Deny Remote Digital Loopback Test request
	&T6	Perform a Remote Digital Loopback Test
	&T7	Perform a Remote Digital Loopback Test and Self-Test
	&T8	Perform Local Analog Loopback Test and Self-Test
&V	&V0	Displays Active and Stored Profiles

Command		Function
	&V1	Display Last Connection Statistics
&W_	&W0	Stores the active profile as Profile 0
	&W1	Stores the active profile as Profile 1
%E_	%E0	Disable auto-retrain
	%E1	Enable auto-retrain
+MS?		Displays the current Select Modulation settings
+MS=?		Displays a list of supported Select Modulation options
+MS=a,b,c,e,f		Select modulation where: a =0, 1, 2, 3, 9, 10, 11, 12, 56, 64, 69; b =0-1; c =300-56000; d =300-56000; e =0-1; and f =0-1. A, b, c, d, e, f default= 12, 1, 300, 56000, 0, 0 . Parameter " a " specifies the modulation protocol desired where: 0=V.21, 1=V.22, 2=V.22bis, 3=V.23, 9=V.32, 10=V.32bis, 11=V.34, 12=V.90,K56Flex,V.34.....,56=K 56Flex, V.90,V.34....., 64=Bell 103, and 69=Bell 212. Parameter " b " specifies automode operations where: 0=automode disabled, 1= automode enabled with V.8/V.32 Annex A. Parameter " c " specifies the minimum connection data rate (300- 56000). Parameter " d " specifies the maximum connection rate (300-56000); Parameter " e " specifies the codec type (0= Law, and 1=A-Law). Parameter " f " specifies "robbed bit" signaling detection (0=detection disabled 1=detection enabled)

MNP/V.42/V.42bis/V.44 commands

Command		Function
%C_	%C0	Disable MNP Class 5 and V.42bis data compression
	%C1	Enable MNP Class 5 data compression only
	%C2	Enable V.42bis data compression only
	%C3	Enable MNP Class 5 and V.42bis data compression
&Q_	&Q0	Direct data link only (same as \N1)
	&Q5	V.42 data link with fallback options
	&Q6	Normal data link only (same as \N0)
+DS44=0, 0		Disable V.44
+DS44=3, 0		Enable V.44
+DS44?		Current values
+DS44=?		List of support values

Fax Class 1 commands

+FAE=n	Data/Fax Auto Answer
+FCLASS=n	Service Class
+FRH=n	Receive data with HDLC framing
+FRM=n	Receive data
+FRS=n	Receive silence
+FTH=n	Transmit data with HDLC framing
+FTM=n	Transmit data
+FTS=n	Stop transmission and wait

Fax Class 2 commands

+FCLASS=n	Services class.
+FAA=n	Adaptive answer.
+FAXERR	Fax error value.
+FBOR	Phase C data bit order.
+FBUF?	Buffer size (read only).
+FCFR	Indicate confirmation to receive.
+FCLASS=	Service class.
+FCON	Facsimile connection response.
+FCIG	Set the polled station identification.
+FCIG:	Report the polled station identification.
+FCR	Capability to receive.
+FCR=	Capability to receive.
+FCSI:	Report the called station ID.
+FDCC=	DCE capabilities parameters.
+FDCS:	Report current session.
+FDCS=	Current session results.
+FDIS:	Report remote capabilities.
+FDIS=	Current sessions parameters.
+FDR	Begin or continue phase C receive data.
+FDT=	Data transmission.
+FDTC:	Report the polled station capabilities.
+FET:	Post page message response.
+FET=N	Transmit page punctuation.
+FHNG	Call termination with status.
+FK	Session termination.
+FLID=	Local ID string.
+FLPL	Document for polling.
+FMDL?	Identify model.
+FMFR?	Identify manufacturer.

+FPHCTO	Phase C time out.
+FPOLL	Indicates polling request.
+FPTS:	Page transfer status.
+FPTS=	Page transfer status.
+FRECV?	Identify revision.
+FSPT	Enable polling.
+FTSI:	Report the transmit station ID.

Voice commands

#BDR	Select Baud Rate
#CID	Enable Caller ID detection and reporting format
#CLS	Select Data, Fax or Voice/Audio
#MDL?	Identify Model
#MFR?	Identify Manufacturer
#REV?	Identify Revision Level
#TL	Audio output transmit level
#VBQ?	Query Buffer Size
#VBS	Bits per sample (ADPCM or PCM)
#VBT	Beep Tone Timer
#VCI?	Identify Compression Method
#VLS	Voice line select
#VRA	Ringback goes away timer
#VRN	Ringback never came timer
#VRX	Voice Receive Mode
#VSDB	Silence deletion tuner
#VSK	Buffer skid setting
#VSP	Silence detection period
#VSR	Sampling rate selection
#VSS	Silence deletion tuner
#VTD	DTMF tone reporting capability
#VTM	Enable timing mark placement
#VTS	Generate tone signals
#VTX	Voice transmit mode

Attention Switzerland User:

If your Swisscom phone line does not have Taxsignal switched OFF, modem function may be impaired. The impairment may be resolved by a filter with the following specifications:

Telekom PTT SCR-BE
Taximpulssperrfilter-12kHz
PTT Art. 444.112.7
Bakom 93.0291.Z.N

Appendix D. Notices

Lenovo may not offer the products, services, or features discussed in this document in all countries. Consult your local Lenovo representative for information on the products and services currently available in your area. Any reference to a Lenovo product, program, or service is not intended to state or imply that only that Lenovo product, program, or service may be used. Any functionally equivalent product, program, or service that does not infringe any Lenovo intellectual property right may be used instead. However, it is the user's responsibility to evaluate and verify the operation of any other product, program, or service.

Lenovo may have patents or pending patent applications covering subject matter described in this document. The furnishing of this document does not give you any license to these patents. You can send license inquiries, in writing, to:

*Lenovo (United States), Inc.
500 Park Offices Drive, Hwy. 54
Research Triangle Park, NC 27709
U.S.A.
Attention: Lenovo Director of Licensing*

LENOVO GROUP LTD. PROVIDES THIS PUBLICATION "AS IS" WITHOUT WARRANTY OF ANY KIND, EITHER EXPRESS OR IMPLIED, INCLUDING, BUT NOT LIMITED TO, THE IMPLIED WARRANTIES OF NON-INFRINGEMENT, MERCHANTABILITY OR FITNESS FOR A PARTICULAR PURPOSE. Some jurisdictions do not allow disclaimer of express or implied warranties in certain transactions, therefore, this statement may not apply to you.

This information could include technical inaccuracies or typographical errors. Changes are periodically made to the information herein; these changes will be incorporated in new editions of the publication. Lenovo may make improvements and/or changes in the product(s) and/or the program(s) described in this publication at any time without notice.

The products described in this document are not intended for use in implantation or other life support applications where malfunction may result in injury or death to persons. The information contained in this document does not affect or change Lenovo product specifications or warranties. Nothing in this document shall operate as an express or implied license or indemnity under the intellectual property rights of Lenovo or third parties. All information contained in this document was obtained in specific environments and is presented as an illustration. The result obtained in other operating environments may vary.

Lenovo may use or distribute any of the information you supply in any way it believes appropriate without incurring any obligation to you.

Any references in this publication to non-Lenovo Web sites are provided for convenience only and do not in any manner serve as an endorsement of those Web sites. The materials at those Web sites are not part of the materials for this Lenovo product, and use of those Web sites is at your own risk.

Any performance data contained herein was determined in a controlled environment. Therefore, the result obtained in other operating environments may

vary significantly. Some measurements may have been made on development-level systems and there is no guarantee that these measurements will be the same on generally available systems. Furthermore, some measurements may have been estimated through extrapolation. Actual results may vary. Users of this document should verify the applicable data for their specific environment.

Television output notice

The following notice applies to models that have the factory-installed television-output feature.

This product incorporates copyright protection technology that is protected by method claims of certain U.S. patents and other intellectual property rights owned by Macrovision Corporation and other rights owners. Use of this copyright protection technology must be authorized by Macrovision Corporation, and is intended for home and other limited viewing uses only unless otherwise authorized by Macrovision Corporation. Reverse engineering or disassembly is prohibited.

Trademarks

The following terms are trademarks of Lenovo in the United States, other countries, or both:

- Lenovo
- ThinkCentre
- ThinkPad

The following terms are trademarks of International Business Machines Corporation in the United States, other countries, or both:

- IBM (used under license)
- Wake on LAN

Microsoft and Windows are trademarks of Microsoft Corporation in the United States, other countries, or both.

Intel, Celeron, and Pentium are trademarks of Intel Corporation in the United States, other countries, or both.

Linux is a trademark of Linus Torvalds in the United States, other countries, or both.

Other company, product, or service names may be trademarks or service marks of others.

Index

A

- adapters
 - connectors 14
 - installing 14
 - peripheral component interconnect (PCI) 5
- audio line in connector 9
- audio line out connector 9
- audio, subsystem 2

B

- battery location 11
- boot-block recovery 30

C

- cables, connecting 23
- changing the battery 21
- cleaning the mouse 31
- commands
 - Basic AT 33
 - Extended AT 35
 - Fax Class 1 37
 - Fax Class 2 37
 - MNP/V.42/V.42bis/V.44 36
 - Voice 38
- connector description 9
- cover
 - removing 10
 - replacing 23

D

- device, drivers 9
- drives
 - bays 3, 16
 - diskette 5
 - hard disk 5
 - installing 17
 - internal 2, 16
 - optical 5
 - removable media 5
 - specifications 16

E

- environment, operating 4
- Ethernet connector 9

I

- information resources xiii
- input/output (I/O)
 - features 2
- installing options
 - adapters 14
 - internal drives 17
 - memory modules 12, 13

- installing options (*continued*)
 - security features 20

K

- keyboard connector 9

L

- locating components 11

M

- memory
 - dual inline memory modules (DIMMs) 12
 - installing 12
 - system 12
- modem
 - Basic AT commands 33
 - Extended AT commands 35
 - Fax Class 1 commands 37
 - Fax Class 2 commands 37
 - MNP/V.42/V.42bis/V.44 commands 36
 - Voice commands 38
- mouse connector 9

N

- noise level 4

O

- options
 - available 5
 - external 5
 - internal 5
- overview xiii

P

- parallel connector 9
- password
 - considerations 25
 - erasing 23
 - IDE drive master 26
 - IDE drive user 26
 - lost or forgotten 23
 - setting, changing, deleting 27
- physical specifications 4
- power
 - Advanced Configuration and Power Interface (ACPI) support 3
 - Advanced Power Management support 3

R

- recovering from a POST/BIOS update failure 30
- removing the cover 10

replacing the cover 23

S

security

features 3, 20

padlock loop 21

security profile by device 27

serial connector 9

Setup Utility 25

system board

connectors 12

identifying parts 11

location 12

memory 5, 12

system programs 29

U

USB connectors 9

using

passwords 25

security profile by device 27

V

video, subsystem 2

ThinkCentre®

Part Number: 19R0462

Printed in USA

(1P) P/N: 19R0462

