



# Intel® Celeron® Processor for the PGA370 Socket up to 1.40 GHz on 0.13 Micron Process

*Datasheet*

## Product Features

- Available at 1.4 GHz, 1.30 GHz, 1.20 GHz, 1.10A GHz, 1A GHz and 900 MHz with 100 MHz system bus
- 256 KB on-die Level 2 (L2) cache with Error Correcting Code (ECC)
- Dual Independent Bus (DIB) architecture: Separate dedicated external System Bus and dedicated internal high-speed cache bus
- Internet Streaming SIMD Extensions for enhanced video, sound and 3D performance
- Binary compatible with applications running on previous members of the Intel microprocessor line
- Dynamic execution micro architecture
- Power Management capabilities
  - System Management mode
  - Multiple low-power states
- Optimized for 32-bit applications running on advanced 32-bit operating systems
- Flip Chip Pin Grid Array (FC-PGA2) packaging technology
- Integrated high performance 16 KB instruction and 16 KB data, nonblocking, level one cache
- Integrated Full Speed level two cache allows for low latency on read/store operations
- Error-correcting code for System Bus data

The Intel® Celeron® processor is designed for uni-processor based Value PC desktops and is binary compatible with previous generation Intel architecture processors. The Intel Celeron processor provides good performance for applications running on advanced operating systems such as Windows® 95/98, WindowsNT®, Windows® 2000, WindowsXP® and UNIX®. This is achieved by integrating the best attributes of Intel processors—the dynamic execution performance of the P6 microarchitecture plus the capabilities of MMX™ technology—bringing a balanced level of performance to the Value PC market segment. The Intel Celeron processor offers the dependability you would expect from Intel at an exceptional value. Systems based on Intel Celeron processors also include the latest features to simplify system management and lower the cost of ownership for small business and home environments.



May 2002

Order Number: 298596-004



Information in this document is provided in connection with Intel products. No license, express or implied, by estoppel or otherwise, to any intellectual property rights is granted by this document. Except as provided in Intel's Terms and Conditions of Sale for such products, Intel assumes no liability whatsoever, and Intel disclaims any express or implied warranty, relating to sale and/or use of Intel products including liability or warranties relating to fitness for a particular purpose, merchantability, or infringement of any patent, copyright or other intellectual property right. Intel products are not intended for use in medical, life saving, or life sustaining applications.

Intel may make changes to specifications and product descriptions at any time, without notice.

Designers must not rely on the absence or characteristics of any features or instructions marked "reserved" or "undefined." Intel reserves these for future definition and shall have no responsibility whatsoever for conflicts or incompatibilities arising from future changes to them.

The Intel® Celeron® processor may contain design defects or errors known as errata which may cause the product to deviate from published specifications. Current characterized errata are available on request.

Contact your local Intel sales office or your distributor to obtain the latest specifications and before placing your product order.

Copies of documents which have an ordering number and are referenced in this document, or other Intel literature may be obtained by calling 1-800-548-4725 or by visiting Intel's website at <http://www.intel.com>.

Copyright © Intel Corporation, 2002

Intel, Celeron, MMX, Pentium, and the Intel logo are trademarks or registered trademarks of Intel Corporation or its subsidiaries in the United States and other countries.

\*Other names and brands may be claimed as the property of others.

# Contents

---

1.0	Introduction.....	9
1.1	Terminology.....	10
1.1.1	Package and Processor Terminology .....	10
1.1.2	Processor Naming Convention.....	11
1.2	Related Documents.....	12
2.0	Electrical Specifications.....	13
2.1	Processor System Bus and V <sub>REF</sub> .....	13
2.2	Clock Control and Low Power States.....	14
2.2.1	Normal State—State 1 .....	15
2.2.2	AutoHALT Powerdown State—State 2.....	15
2.2.3	Stop-Grant State—State 3 .....	15
2.2.4	HALT/Grant Snoop State—State 4 .....	15
2.2.5	Sleep State—State 5.....	16
2.2.6	Deep Sleep State—State 6 .....	16
2.2.7	Clock Control.....	17
2.3	Power and Ground Pins .....	17
2.3.1	Phase Lock Loop (PLL) Power.....	17
2.4	Decoupling Guidelines .....	18
2.4.1	Processor VCC <sub>CORE</sub> Decoupling.....	18
2.5	Processor System Bus Clock and Processor Clocking .....	19
2.6	Voltage Identification .....	19
2.7	Processor System Bus Unused Pins.....	21
2.8	Processor System Bus Signal Groups .....	22
2.8.1	Asynchronous vs. Synchronous for System Bus Signals.....	23
2.8.2	System Bus Frequency Select Signals .....	24
2.9	Test Access Port (TAP) Connection.....	25
2.10	Maximum Ratings.....	25
2.11	Processor Voltage Level Specifications .....	25
2.12	AGTL System Bus Specifications.....	30
2.13	System Bus Timing Specifications .....	31
3.0	Signal Quality Specifications .....	41
3.1	BCLK/BCLK# & PICCLK Signal Quality Specifications and Measurement Guidelines .....	41
3.2	AGTL Signal Quality Specifications and Measurement Guidelines.....	42
3.2.1	Overshoot/Undershoot Guidelines .....	43
3.2.2	Overshoot/Undershoot Magnitude .....	44
3.2.3	Overshoot/Undershoot Pulse Duration.....	44
3.2.4	Activity Factor.....	44
3.2.5	Reading Overshoot/Undershoot Specification Tables.....	45
3.2.6	Determining if a System Meets the Overshoot/Undershoot Specifications .....	46
3.3	Non-AGTL Signal Quality Specifications and Measurement Guidelines.....	47
3.3.1	Overshoot/Undershoot Guidelines .....	48
3.3.2	Ringback Specification .....	48
3.3.3	Settling Limit Guideline.....	49



3.4	VTT_PWRGD Signal Quality Specification .....	49
3.4.1	Transition region .....	49
3.4.2	Transition time .....	50
3.4.3	Noise .....	50
4.0	Thermal Specifications and Design Considerations .....	51
4.1	Thermal Specifications .....	51
4.1.1	THERMTRIP# Requirement .....	51
4.1.2	Thermal Diode .....	52
4.2	Thermal Metrology .....	52
5.0	Mechanical Specifications .....	53
5.1	FC-PGA2 Mechanical Specifications .....	53
5.2	Recommended Mechanical Keep-Out Zones .....	55
5.3	Processor Markings .....	56
5.4	Processor Signal Listing .....	57
6.0	Boxed Processor Specifications .....	68
6.1	Mechanical Specifications .....	68
6.1.1	Mechanical Specifications for the FC-PGA2 Package .....	68
6.1.2	Boxed Processor Heatsink Weight .....	70
6.2	Thermal Specifications .....	70
6.2.1	Boxed Processor Cooling Requirements .....	70
6.2.2	Boxed Processor Thermal Cooling Solution Clip .....	71
6.3	Electrical Requirements for the Boxed Processor .....	71
6.3.1	Electrical Requirements .....	71
7.0	Processor Signal Description .....	73
7.1	Alphabetical Signals Reference .....	73
7.2	Signal Summaries .....	80



## List of Figures

1	Integrated Heat Spreader (IHS) .....	9
2	AGTL Bus Topology in a Uniprocessor Configuration.....	14
3	Stop Clock State Machine .....	14
4	PLL Filter Specification.....	18
5	Differential/Single-Ended Clocking Example.....	19
6	VTT Power Good and Bus Select Interconnect Diagram .....	21
7	BSEL[1:0] Example for a System Design.....	24
8	Vcc Static and Transient Tolerance .....	28
9	Clock Waveform .....	36
10	BCLK/BCLK#, PICCLK, and TCK Generic Clock Waveform .....	37
11	System Bus Valid Delay Timings .....	37
12	System Bus Setup and Hold Timings.....	38
13	System Bus Reset and Configuration Timings.....	38
14	Platform Power-On Sequence and Timings.....	39
15	Power-On Reset and Configuration Timings.....	39
16	Test Timings (TAP Connection) .....	40
17	Test Reset Timings .....	40
18	BCLK/BCLK#, PICCLK Generic Clock Waveform at the Processor Pins .....	42
19	Low to High AGTL Receiver Ringback Tolerance.....	43
20	Maximum Acceptable AGTL Overshoot/Undershoot Waveform .....	47
21	Non-AGTL Overshoot/Undershoot, Settling Limit, and Ringback .....	47
22	Noise Estimation .....	50
23	Package Dimensions.....	53
24	Volumetric Keep-Out.....	55
25	Component Keep-Out .....	55
26	Top Side Processor Markings .....	56
27	Processor Pinout.....	57
28	Conceptual Boxed Processor for the PGA370 Socket .....	68
29	Comparison between FC-PGA and FC-PGA2 package.....	69
30	Side View of Space Requirements for the Boxed Processor .....	69
31	Dimensions of Mechanical Step Feature in Heatsink Base.....	70
32	Thermal Airspace Requirement for all Boxed Processor Fan Heatsinks in the PGA370 Socket .....	71
33	Boxed Processor Fan Heatsink Power Cable Connector Description.....	72
34	Motherboard Power Header Placement Relative to the Boxed Processor.....	72

## List of Tables

1	Processor Identification .....	11
2	System Bus Clock in Deep Sleep Mode (Differential Mode only) .....	16
3	Voltage Identification Definition .....	20
4	System Bus Signal Groups .....	23
5	Frequency Select Truth Table for BSEL[1:0] .....	24
6	Absolute Maximum Ratings .....	25
7	Voltage and Current Specifications .....	26
8	Power Supply Current Slew Rate (dlccore/dt) .....	27
9	Vcc Static & Transient Tolerance .....	28
10	AGTL Signal Group Levels Specifications .....	29
11	Non-AGTL Signal Group Levels Specifications .....	29
12	3.3 Volt CMOS Output Signal Group DC Specifications .....	30
13	Processor AGTL Bus Specifications .....	30
14	System Bus Timing Specifications (Single-Ended Clock) .....	31
15	System Bus Timing Specifications (Differential Clock) .....	32
16	Valid System Bus to Core Frequency Ratios .....	33
17	System Bus Timing Specifications (AGTL Signal Group) .....	33
18	System Bus Timing Specifications (CMOS Signal Group) .....	33
19	System Bus Timing Specifications (Reset Conditions) .....	34
20	System Bus Timing Specifications (APIC Clock and APIC I/O) .....	34
21	System Bus Timing Specifications (TAP Connection) .....	35
22	Platform Power-On Timings .....	36
23	BCLK (Single-Ended Clock Mode) Signal Quality Specifications for Simulation at the Processor Pins .....	41
24	BCLK/BCLK# (Differential Clock Mode) and PICCLK Signal Quality Specifications for Simulation at the Processor Pins .....	41
25	AGTL Signal Groups Ringback Tolerance Specifications at the Processor Pins .....	42
26	Example Platform Information .....	45
27	100 MHz AGTL Signal Group Overshoot/Undershoot Tolerance .....	46
28	33 MHz CMOS Signal Group Overshoot/Undershoot Tolerance .....	48
29	Signal Ringback Specifications for Non-AGTL Signal Simulation at the Processor Pins .....	49
30	Processor Thermal Design Power .....	51
31	THERMTRIP# Time Requirement .....	51
32	Thermal Diode Parameters .....	52
33	Thermal Diode Interface .....	52
34	The Processor Package Dimensions .....	54
35	Processor Case Loading Parameters .....	54
36	Signal Listing in Order by Signal Name .....	58
37	Signal Listing in Order by Pin Number .....	63
38	Boxed Processor Fan Heatsink Spatial Dimensions .....	70
39	Fan Heatsink Power and Signal Specifications .....	72
40	Signal Description .....	73
41	Output Signals .....	80
42	Input Signals .....	80
43	Input/Output Signals (Single Driver) .....	81
44	Input/Output Signals (Multiple Driver) .....	82



## Revision History

---

Revision	Date	Description
-004	May 2002	<ul style="list-style-type: none"><li>Added 1.4 GHz processor information; Added Section 3.4, "VTT_PWRGD Signal Quality Specification"; Updated Table 40, "Signal Description" for <math>V_{CMOS\_REF}</math></li></ul>



This page is intentionally left blank.



## 1.0 Introduction

---

The Intel<sup>®</sup> Celeron<sup>®</sup> processor based on 0.13 micron process core for the PGA370 socket is the next member of the P6 family, in the Intel IA-32 processor line and hereafter will be referred to as simply “the processor”. The processor will continue in the package technology called flip-chip pin grid array but will contain an Integrated Heat Spreader (IHS) (see [Figure 1](#)). The flip-chip with IHS package will be labeled as FC-PGA2 and will utilize the same 370-pin zero insertion force socket (PGA370). Thermal solutions contact the IHS directly for the FC-PGA2 package and not to the bare-die as with the FC-PGA attachment.

The processor, like its predecessors in the P6 family of processors, implements a Dynamic Execution microarchitecture—a unique combination of multiple branch prediction, data flow analysis, and speculative execution. The processor delivers higher performance than the Intel<sup>®</sup> Celeron<sup>®</sup> processor based on 0.18 micron process core, while maintaining binary compatibility with all previous Intel Architecture processors. The processor also executes Intel<sup>®</sup> MMX<sup>™</sup> technology instructions for enhanced media and communication performance just as the predecessor Celeron processor based on 0.18 micron process core. Additionally, the processor executes Streaming SIMD (single-instruction, multiple data) Extensions for enhanced floating point and 3-D application performance. The processor utilizes multiple low-power states such as Stop-Grant, Sleep, and Deep Sleep to conserve power during idle times.

The processor includes an integrated on-die, 256KB 8-way set associative level-two (L2) cache. The L2 cache implements the Advanced Transfer Cache Architecture with a 256-bit wide bus. The processor also includes a 16 KB level one (L1) instruction cache and 16 KB L1 data cache. These cache arrays run at the full speed of the processor core. The processor for the PGA370 socket has a dedicated L2 cache bus, thus maintaining the dual independent bus architecture to deliver high bus bandwidth and performance. Memory is cacheable for 64 GB of addressable memory space, allowing significant headroom for desktop systems. Refer to the Specification Update document for this processor to determine the cacheability and cache configuration options for a specific processor. Contact your nearest Intel Sales Representative for the latest Processor Specification Update.

**Figure 1. Integrated Heat Spreader (IHS)**

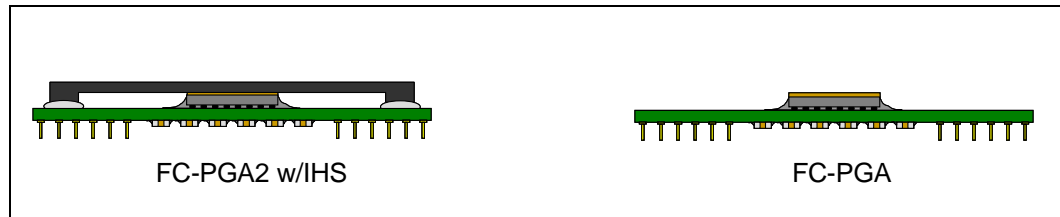

The processor will support a lower voltage differential and single-ended clocking for the system bus. The previous generation Intel Celeron processors for the PGA370 socket will function in a platform that supports this processor, if the platform has been designed to be backward compatible. In addition, the processor will not function in a previous generation platform due to incompatible system bus signal levels and clock type. Care must be taken to ensure the correct processors are installed in the correct PGA370 socket platforms.

## 1.1 Terminology

In this document, a '#' symbol after a signal name refers to an active low signal. This means that a signal is in the active state (based on the name of the signal) when driven to a low level. For example, when FLUSH# is low, a flush has been requested. When NMI is high, a nonmaskable interrupt has occurred. In the case of signals where the name does not imply an active state but describes part of a binary sequence (such as *address* or *data*), the '#' symbol implies that the signal is inverted. For example, D[3:0] = 'HLHL' refers to a hex 'A', and D[3:0]# = 'LHLH' also refers to a hex 'A' (H= High logic level, L= Low logic level).

The term "system bus" refers to the interface between the processor, system core logic (a.k.a. the chipset components), and other bus agents.

### 1.1.1 Package and Processor Terminology

The following terms are used often in this document and are explained here for clarification:

- **The processor** - The entire product including all internal components.
- **256k UP processor** - The desktop version of the 0.13 micron process processor. Contains 256KB of L2 cache and is uni-processor capable only.
- **PGA370 socket** - 370-pin Zero Insertion Force (ZIF) socket which a FC-PGA packaged processor plugs into.
- **FC-PGA** - Flip Chip Pin Grid Array. The package technology used on processors based on the 0.18 micron process for the PGA370 socket. The FC-PGA package has the processor die exposed.
- **FC-PGA2** - Flip Chip Pin Grid Array 2. The package technology used on the processor for the PGA370 socket. The FC-PGA2 package contains an Integrated Heat Spreader which covers the processor die.
- **Advanced Transfer Cache (ATC)** - L2 cache architecture used on the Celeron® processors. ATC consists of microarchitectural improvements that provide a higher data bandwidth interface into the processor core that is completely scaleable with the processor core frequency.
- **Keep-out zone** - The area on or near a FC-PGA packaged processor that system designs can not utilize.
- **Keep-in zone** - The area of a FC-PGA packaged processor that thermal solutions may utilize.
- **Processor** - For this document, the term processor is the generic form of the Celeron® processor based on 0.13 micron process core for the PGA370 socket in the FC-PGA2 package.
- **Processor core** - The processor's execution engine.
- **Integrated Heat Spreader (IHS)** - The Integrated Heat Spreader (IHS) is a metal cover on the die and it is an integral part of the processor. The IHS promotes heat spreading away from the die backside to ease thermal constraints.

The cache and L2 cache are industry designated names.



## 1.1.2 Processor Naming Convention

Table 1. Processor Identification

Processor	Core Frequency	System Bus Frequency (MHz)	L2 Cache Size (Kbytes)	L2 Cache Type <sup>2</sup>	CPUID <sup>1</sup>
1.4	1.40	100	256	ATC	06Bxh
1.30	1.30 GHz	100	256	ATC	06Bxh
1.20 <sup>3</sup>	1.20 GHz	100	256	ATC	06Bxh
1.20	1.20 GHz	100	256	ATC	06Bxh
1.10A	1.10A GHz	100	256	ATC	06Bxh
1A	1A GHz	100	256	ATC	06Bxh
900	900 MHz	100	256	ATC	06Bxh

**NOTES:**

1. Refer to the *Intel® Celeron® Processor Specification Update* for the exact CPUID for each processor.
2. ATC = Advanced Transfer Cache. ATC is an L2 Cache integrated on the same die as the processor core. With ATC, the interface between the processor core and L2 Cache is 256-bits wide, runs at the same frequency as the processor core and has enhanced buffering.
3. 1.20 GHz at  $V_{CC_{CORE}} = 1.475$  volts and S-Spec number SL5XS.

## 1.2 Related Documents

The reader of this specification should also be familiar with material and concepts presented in the following documents <sup>1,2</sup>:

Document	Intel Order Number
AP-485, <i>Intel® Processor Identification and the CPUID Instruction</i>	241618
AP-589, <i>Design for EMI</i>	243334
<i>Intel® Architecture Software Developer's Manual</i>	243193
Volume I: Basic Architecture	243190
Volume II: Instruction Set Reference	243191
Volume III: System Programming Guide	243192
<i>P6 Family of Processors Hardware Developer's Manual</i>	244001
IA-32 Processors and Related Products 1999 Databook	243565
<i>370-Pin Socket (PGA370) Design Guidelines</i>	244410
PGA370 Heat Sink Cooling in MicroATX Chassis	245025
815 B-step Chipset Platform Design Guide <sup>3</sup>	
CK-815 Clock Synthesizer/Driver Specification <sup>3</sup>	
CK-408 Clock Synthesizer/Driver Specification <sup>3</sup>	
<i>VRM 8.5 DC-DC Converter Design Guidelines</i> <sup>3</sup>	249659
Extensions to the Pentium® Pro Processor BIOS Writer's Guide Revision <sup>3</sup>	
<i>Intel® Pentium® III Processor in the FC-PGA2, 370-pin Package Thermal Design Guidelines</i> <sup>3</sup>	249660

### NOTES:

1. Unless otherwise noted, this reference material can be found on the Intel Developer's Website located at <http://developer.intel.com>.
2. For a complete listing of Intel Celeron processor reference material, please refer to the Intel Developer's Website at <http://developer.intel.com/design/Celeron/>.
3. This material is available through an Intel Field Sales Representative.

## 2.0 Electrical Specifications

---

### 2.1 Processor System Bus and $V_{REF}$

The processor uses the original low voltage signaling of the Gunning Transceiver Logic (GTL) technology for the system bus. The GTL system bus operates at 1.25V signal levels versus GTL+ which operates at 1.5 V signal levels. The GTL+ signal technology is used by the Intel<sup>®</sup> Pentium<sup>®</sup> Pro, Intel<sup>®</sup> Pentium<sup>®</sup> II and Intel<sup>®</sup> Pentium<sup>®</sup> III processors.

Current P6 family processors vary from the Intel<sup>®</sup> Pentium<sup>®</sup> Pro processor in their output buffer implementation. The buffers that drive the system bus signals on the processor are actively driven to  $V_{TT}$  for one clock cycle after the low to high transition to improve rise times. These signals are open-drain and require termination to a supply. Because this specification is different from the standard GTL specification, it is referred to as AGTL, or Assisted GTL in this and other documentation related to the processor.

AGTL logic and AGTL+ logic are not compatible with each other due to differences with the signal switching levels. The processor cannot be installed into platforms where the chipset only supports the AGTL+ signal levels. For more information on AGTL or AGTL+ routing, please refer to the appropriate platform design guide.

AGTL inputs use differential receivers which requires a reference voltage ( $V_{REF}$ ).  $V_{REF}$  is used by the differential receivers to determine if the input signal is a logical 0 or a logical 1. The  $V_{REF}$  signal is typically implemented as a voltage divider on the platform. Noise decoupling is critical for the  $V_{REF}$  signal. Refer to the platform design guide for the recommended decoupling requirements. Another important item for the AGTL system bus is termination.

System bus termination is used to pull each signal to a high voltage level and to control reflections on the transmission line. The processor contains on-die termination resistors that provide termination for one end of the system bus. The other end of the system bus should also be terminated near the chipset by resistors placed on the platform or on-die termination within the chipset. It is recommended that the system bus is implemented using Dual-End Termination (DET) to meet the timings and signal integrity specified by the processor. [Figure 2](#) is a schematic representation of the AGTL bus topology for the processor, when the chipset has does not have on-die termination.

**Note:** The RESET# signal requires a discrete external termination resistor on the system board.

The AGTL bus depends on incident wave switching. Therefore, timing calculations for AGTL signals are based on flight time as opposed to capacitive deratings. Analog signal simulations of the system bus, including trace lengths, is highly recommended especially when not following the recommended layout guidelines.

Figure 2. AGTL Bus Topology in a Uniprocessor Configuration

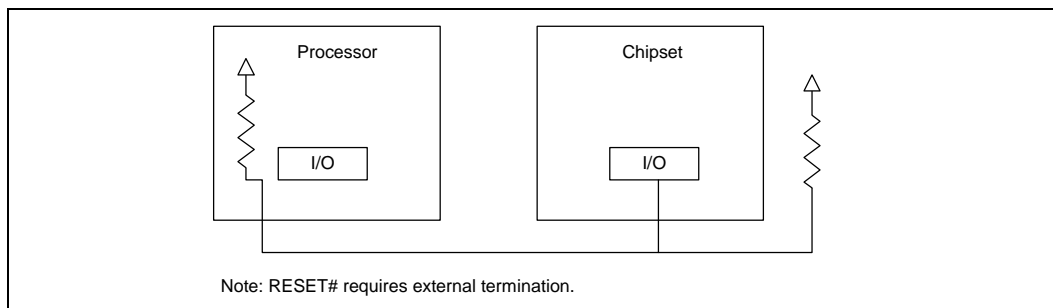

## 2.2 Clock Control and Low Power States

Processors allow the use of Sleep, and Deep Sleep states to reduce power consumption by stopping the clock to internal sections of the processor, depending on each particular state. See Figure 3 for a visual representation of the processor low power states.

Figure 3. Stop Clock State Machine

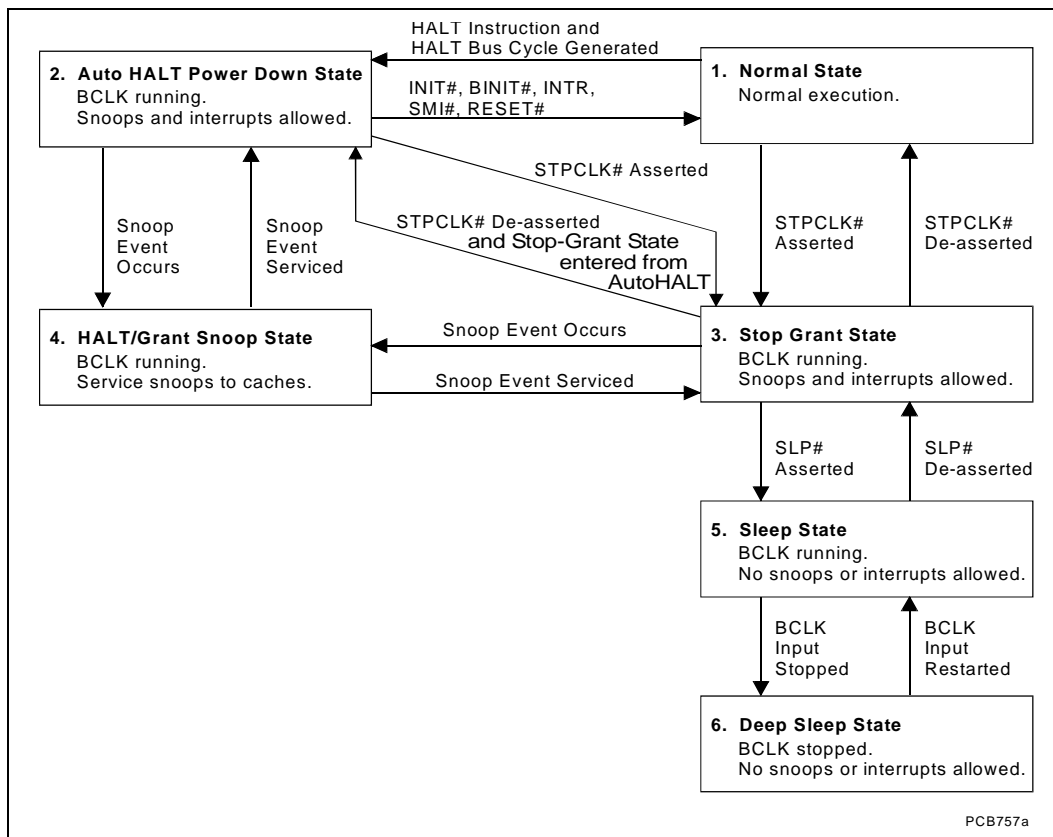

For the processor to fully realize the low current consumption of the Stop-Grant, Sleep and Deep Sleep states, a Model Specific Register (MSR) bit must be set. For the MSR at 02AH (Hex), bit 26 must be set to a '1' (this is the power on default setting) for the processor to stop all internal clocks during these modes. For more information, see the *Intel Architecture Software Developer's Manual, Volume 3: System Programming Guide*.

### 2.2.1 Normal State—State 1

This is the normal operating state for the processor.

### 2.2.2 AutoHALT Powerdown State—State 2

AutoHALT is a power state entered when the processor executes the HALT instruction. The processor transitions to the Normal state upon the occurrence of SMI#, INIT#, or LINT[1:0] (NMI, INTR). RESET# causes the processor to immediately initialize itself.

The return from a System Management Interrupt (SMI) handler can be to either Normal Mode or the AutoHALT Power Down state. See the *Intel Architecture Software Developer's Manual, Volume III: System Programmer's Guide* for more information.

FLUSH# is serviced during the AutoHALT state, and the processor will return to the AutoHALT state.

The system can generate a STPCLK# while the processor is in the AutoHALT Power Down state. When the system deasserts the STPCLK# interrupt, the processor returns execution to the HALT state.

### 2.2.3 Stop-Grant State—State 3

The Stop-Grant state on the processor is entered when the STPCLK# signal is asserted.

Since the AGTL signal pins receive power from the system bus, these pins should not be driven (allowing the level to return to VTT) for minimum power drawn by the termination resistors in this state. In addition, all other input pins on the system bus should be driven to the inactive state.

BINIT# and FLUSH# are not serviced during the Stop-Grant state.

RESET# causes the processor to immediately initialize itself, but the processor stays in Stop-Grant state. A transition back to the Normal state occurs with the deassertion of the STPCLK# signal.

A transition to the HALT/Grant Snoop state occurs when the processor detects a snoop on the system bus (see [Section 2.2.4](#)). A transition to the Sleep state (see [Section 2.2.5](#)) occurs with the assertion of the SLP# signal.

While in Stop-Grant State, SMI#, INIT#, and LINT[1:0] are latched by the processor, and only serviced when the processor returns to the Normal state. Only one occurrence of each event is recognized and serviced upon return to the Normal state.

### 2.2.4 HALT/Grant Snoop State—State 4

The processor responds to snoop transactions on the system bus while in Stop-Grant state or in AutoHALT Power Down state. During a snoop transaction, the processor enters the HALT/Grant Snoop state. The processor stays in this state until the snoop on the system bus has been serviced (whether by the processor or another agent on the system bus). After the snoop is serviced, the processor returns to the Stop-Grant state or AutoHALT Power Down state, as appropriate.

## 2.2.5 Sleep State—State 5

The Sleep state is a very low power state in which the processor maintains its context, maintains the phase-locked loop (PLL), and has stopped all internal clocks. The Sleep state can only be entered from the Stop-Grant state. Once in the Stop-Grant state, the SLP# pin can be asserted, causing the processor to enter the Sleep state. The SLP# pin is not recognized in the Normal or AutoHALT states.

Snoop events that occur while in Sleep State or during a transition into or out of Sleep state will cause unpredictable behavior.

In the Sleep state, the processor is incapable of responding to snoop transactions or latching interrupt signals. No transitions or assertions of signals (with the exception of SLP# or RESET#) are allowed on the system bus while the processor is in Sleep state. Any transition on an input signal before the processor has returned to Stop-Grant state will result in unpredictable behavior.

If RESET# is driven active while the processor is in the Sleep state, and held active as specified in the RESET# pin specification, then the processor will reset itself, ignoring the transition through Stop-Grant State. If RESET# is driven active while the processor is in the Sleep State, the SLP# and STPCLK# signals should be deasserted immediately after RESET# is asserted to ensure the processor correctly executes the reset sequence.

While in the Sleep state, the processor is capable of entering its lowest power state, the Deep Sleep state, by stopping the BCLK input (see Section 2.2.6). Once in the Sleep state, the SLP# pin can be deasserted if another asynchronous system bus event occurs. The SLP# pin has a minimum assertion of one BCLK period.

## 2.2.6 Deep Sleep State—State 6

The Deep Sleep state is the lowest power state the processor can enter while maintaining context. The Deep Sleep state is entered by stopping the BCLK input (after the Sleep state was entered from the assertion of the SLP# pin). The processor is in Deep Sleep state immediately after BCLK is stopped. BCLK and BCLK# have to be separated by at least 0.2V during the Deep Sleep State. Stopping of the BCLK input lowers the overall current consumption to leakage levels.

To re-enter the Sleep state, the BCLK input must be restarted. A period of 1 ms (to allow for PLL stabilization) must occur before the processor can be considered to be in the Sleep state. Once in the Sleep state, the SLP# pin can be deasserted to re-enter the Stop-Grant state.

While in Deep Sleep state, the processor is incapable of responding to snoop transactions or latching interrupt signals. No transitions or assertions of signals are allowed on the system bus while the processor is in Deep Sleep state. Any transition on an input signal before the processor has returned to Stop-Grant state will result in unpredictable behavior.

**Table 2. System Bus Clock in Deep Sleep Mode (Differential Mode only)**

Symbol	Parameter	Min	Max	Units	Notes <sup>1</sup>
$V_{\text{BCLK}}$	BCLK Voltage Level when not active	0.4	1.45	V	2
$V_{\text{BCLK}} - V_{\text{BCLK\#}}$	BCLK# Voltage Level when not active	0	$V_{\text{BCLK}} - 0.2$	V	2

**NOTES:**

- The values in this table are based on differential probe measurement of the Bclk.
- The DC voltage level specified must be maintained when the system bus clock is not active (e.g., Deep Sleep Mode).  $V_{\text{BCLK\#}}$  has to be 200 mV less than  $V_{\text{BCLK}}$ .



### 2.2.7 Clock Control

BCLK provides the clock signal for the processor and on-die L2 cache. During AutoHALT Power Down and Stop-Grant states, the processor will process a system bus snoop. The processor does not stop the clock to the L2 cache during AutoHALT Power Down or Stop-Grant states. Entrance into the Halt/Grant Snoop state allows the L2 cache to be snooped, similar to the Normal state.

When the processor is in Sleep and Deep Sleep states, it does not respond to interrupts or snoop transactions. During the Sleep state, the internal clock to the L2 cache is not stopped. During the Deep Sleep state, the internal clock to the L2 cache is stopped. The internal clock to the L2 cache is restarted only after the internal clocking mechanism for the processor is stable (i.e., the processor has re-entered Sleep state).

PICCLK should not be removed during the AutoHALT Power Down or Stop-Grant states. PICCLK can be removed during the Sleep or Deep Sleep states. When transitioning from the Deep Sleep state to the Sleep state, PICCLK must be restarted with BCLK.

## 2.3 Power and Ground Pins

The operating voltage for the processor is the same for the core and the L2 cache.  $V_{CC_{CORE}}$  is defined as the power pins that supply voltage to the processor's core and cache. The Voltage Regulator Module (VRM) or Voltage Regulator are controlled by the five voltage identification (VID) signals driven by the processor. The VID signals specify the voltage required by the processor core. Refer to [Section 2.6](#) for further details on the VID voltage settings.

The processor has 74  $V_{CC_{CORE}}$ , 7  $V_{REF}$ , 20  $V_{TT}$ ,  $V_{CC_{CMOS1.5}}$ ,  $V_{CC_{CMOS1.8}}$ ,  $V_{CC_{CMOS2.0}}$  and 74  $V_{SS}$  inputs. The  $V_{REF}$  inputs are used as the AGTL reference voltage for the processor. The  $V_{TT}$  inputs (1.25V) are used to provide an AGTL termination voltage to the processor.  $V_{CC_{CMOS1.5}}$  and  $V_{CC_{CMOS1.8}}$  and  $V_{CC_{CMOS2.0}}$  are not voltage input pins to the processor but rather voltage sources for the pullup resistors which are connected to CMOS (non-AGTL) input/output signals driven to/from the processor. The  $V_{SS}$  inputs are ground pins for the processor core and L2 cache.

On the platform, all  $V_{CC_{CORE}}$  pins must be connected to a voltage island (an island is a portion of a power plane that has been divided, or an entire plane) to minimize any voltage drop that may occur due to trace impedance. It is also highly recommended for the platform to provide either a voltage island or a wide trace for the  $V_{TT}$  pins. Similarly, all  $V_{SS}$  pins must be connected to a system ground plane. These recommendations can be found in the platform design guide layout section.

### 2.3.1 Phase Lock Loop (PLL) Power

It is highly critical that phase lock loop power delivery to the processor meets Intel's requirements. A low pass filter is required for power delivery to pins PLL1 and PLL2. This serves as an isolated, decoupled power source for the internal PLL. Refer to the Phase Lock Loop Power section in the appropriate platform design guide for the recommended filter implementation.

Figure 4. PLL Filter Specification

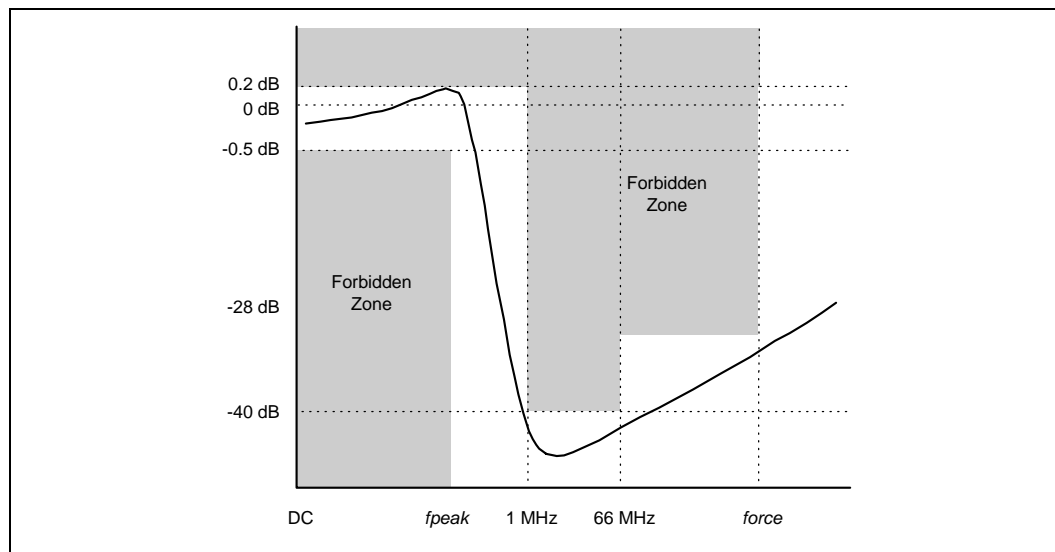

## 2.4 Decoupling Guidelines

Due to the large number of transistors and high internal clock speeds, the processor is capable of generating large average current swings between low and full power states. The fluctuations can cause voltages on power planes to sag below their nominal values if bulk decoupling is not adequate. Care must be taken in the board design to ensure that the voltage provided to the processor remains within the specifications listed in Table 7. Failure to do so can result in timing violations (in the event of a voltage sag) or a reduced lifetime of the component (in the event of a voltage overshoot).

### 2.4.1 Processor $V_{CC_{CORE}}$ Decoupling

The regulator for the  $V_{CC_{CORE}}$  input must be capable of delivering the  $dI_{CC_{CORE}}/dt$  (defined in Table 7) while maintaining the required tolerances (also defined in Table 7). Failure to meet these specifications can result in timing violations (during  $V_{CC_{CORE}}$  sag) or a reduced lifetime of the component (during  $V_{CC_{CORE}}$  overshoot).

The processor requires both high frequency and bulk decoupling on the system motherboard for proper AGTL bus operation. The minimum recommendation for the processor decoupling requirement is listed below. All capacitors should be placed next to and within the PGA370 socket cavity and mounted on the primary side of the motherboard. The capacitors are arranged to minimize the overall inductance between the  $V_{CC_{CORE}}$  and  $V_{SS}$  power pins.

Decoupling Recommendations:

- $V_{CC_{CORE}}$  decoupling: A minimum of sixteen 4.7  $\mu$ F capacitors in a 1206 package.
- VTT decoupling: Twenty 0.1  $\mu$ F capacitors in 0603 packages.
- $V_{REF}$  decoupling: 0.1  $\mu$ F and 0.001  $\mu$ F capacitors in 0603 package placed near the  $V_{REF}$  pins.

For additional decoupling requirements, refer to the appropriate platform design guide for recommended capacitor component value/quantity and placement.

## 2.5 Processor System Bus Clock and Processor Cloning

The processor will implement an auto-detect mechanism that will allow the processor to use either single-ended or differential signaling for the system bus and processor clocking. The processor checks to see if the signal on pin Y33 is toggling. If this signal is toggling then the processor operates in differential mode. Refer to Figure 5 for an example on differential clocking. Resistor values and clock topology are listed in the appropriate platform design guide for a differential implementation.

**Note:** References to BCLK throughout this document will also imply to its complement signal, BCLK# in differential implementations, and when noted otherwise.

Since legacy PGA370 socket platforms use a different single-ended clocking specification than the processor, the processor will not function when placed into these platforms. The BCLK input directly controls the operating speed of the system bus interface. All AGTL system bus timing parameters are specified with respect to the crossing point of the rising edge of the BCLK and the falling edge of BCLK# inputs in a differential implementation. See the *P6 Family of Processors Hardware Developer's Manual* for further details. The reference voltage of the BCLK in the *P6 Family of Processors Hardware Developer Manual* is re-defined as the crossing point of the BCLK and BCLK# in a differential implementation.

Figure 5. Differential/Single-Ended Cloning Example

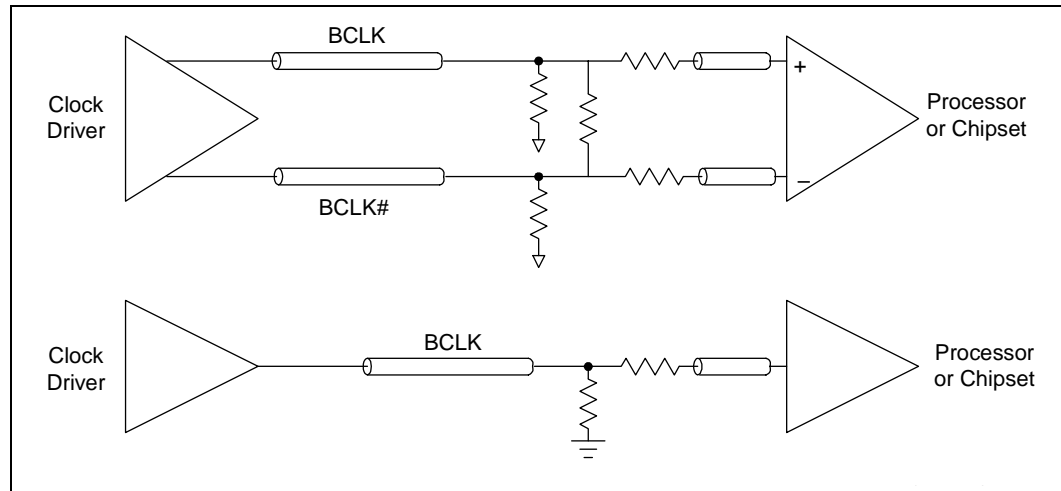

## 2.6 Voltage Identification

There are five voltage identification (VID) pins on the PGA370 socket. These pins can be used to support automatic selection of  $V_{CC_{CORE}}$  voltages. The VID pins for the processor are open drain signals versus opens or shorts found on the previous Intel Celeron FC-PGA processor. Refer to Table 11 for level specifications for the VID signals. This pull-up resistor may be either external logic on the motherboard or internal to the Voltage Regulator.

The VID signals rely on a 3.3 V pull-up resistor to set the signal to a logic high level. The VID pins are needed to fully support voltage specification variations on current and future processors. The voltage selection range for the processor is defined in Table 3. The VID25mV signal is a new signal that allows the voltage regulator or voltage regulator module (VRM) to output voltage levels in 25 mV increment necessary for the processor only. The current Celeron processor in the FC-PGA package will not have this VID25mV signal. The VID25mV pin location is actually a Vss pin

on the model 68xh based on 0.18 micron process core processor. By connecting the VID25mV signal to the Vss pin, it will disable the 25 mV stepping granularity output and the regulator will resort to 50 mV stepping increment. The voltage regulator or VRM must supply the voltage that is requested or disable itself.

In addition to the new signal “VID25mV”, the processor will introduce a second new signal labeled as “VTT\_PWRGD”. The VTT\_PWRGD signal informs the platform that the VID and BSEL signals are stable and should be sampled. During Power-up, the VID signals will be in an indeterminate state for a small period of time. The voltage regulator or the VRM should not latch the VID signals until the VTT\_PWRGD signal is asserted by the VRM and sampled active. The assertion of the VTT\_PWRGD signal indicates the VID signals are stable and are driven to the final state by the processor. Refer to [Figure 14](#) for power-up timing sequence for the VTT\_PWRGD and the VID signals.

**Table 3. Voltage Identification Definition <sup>1</sup>**

VID25mV	VID3	VID2	VID1	VID0	VCC <sub>CORE</sub>
0	0	1	0	0	1.05
1	0	1	0	0	1.075
0	0	0	1	1	1.10
1	0	0	1	1	1.125
0	0	0	1	0	1.15
1	0	0	1	0	1.175
0	0	0	0	1	1.20
1	0	0	0	1	1.225
0	0	0	0	0	1.25
1	0	0	0	0	1.275
0	1	1	1	1	1.30
1	1	1	1	1	1.325
0	1	1	1	0	1.35
1	1	1	1	0	1.375
0	1	1	0	1	1.40
1	1	1	0	1	1.425
0	1	1	0	0	1.45
1	1	1	0	0	1.475
0	1	0	1	1	1.50
1	1	0	1	1	1.525
0	1	0	1	0	1.55
1	1	0	1	0	1.575
0	1	0	0	1	1.60
1	1	0	0	1	1.625
0	1	0	0	0	1.65
1	1	0	0	0	1.675
0	0	1	1	1	1.70
1	0	1	1	1	1.725
0	0	1	1	0	1.75
1	0	1	1	0	1.775
0	0	1	0	1	1.80
1	0	1	0	1	1.825

**NOTES:**

- 0 = Processor pin connected to Vss. and 1 = Open on processor; may be pulled up to TTL V<sub>IH</sub> (3.3 V max) on baseboard.

The VID pins should be pulled up to a 3.3 V level. This may be accomplished with pull-ups internal to the voltage regulator, which ensures valid VID pull-up voltage during Power-up and Power-down sequences. If external resistors are used for the VID[3:0, 25mV] signal, then the power source must be guaranteed to be stable whenever the supply to the voltage regulator is stable. This will prevent the possibility of the processor supply going above the specified  $V_{CC_{CORE}}$  in the event of a failure in the supply for the VID lines. In the case of a DC-to-DC converter, this can be accomplished by using the input voltage to the converter for the VID line pull-ups. A resistor equal to 1 kΩ may be used to connect the VID signals to the voltage regulator input.

**Note:** Intel requires that designs utilize VRM 8.5 and Not VRM 8.4 guidelines to meet the processor requirements.

To re-emphasize, VRM 8.5 introduces two new signals [VID25mV and VTT\_PWRGD] that is utilized by the processor and platform. Ignoring and not connecting these two new pins, as documented in the Platform Design Guidelines, will prevent the processor from operating at the specified voltage levels and core frequency. Figure 6 provides a high-level interconnection schematic. Refer to the *VRM 8.5 DC-DC Converter Design Guideline* and the appropriate Platform Design Guidelines for further detailed information on the voltage identification and bus select implementation. Refer to Figure 14 for VID power-up sequence and timing requirements.

**Figure 6. VTT Power Good and Bus Select Interconnect Diagram**

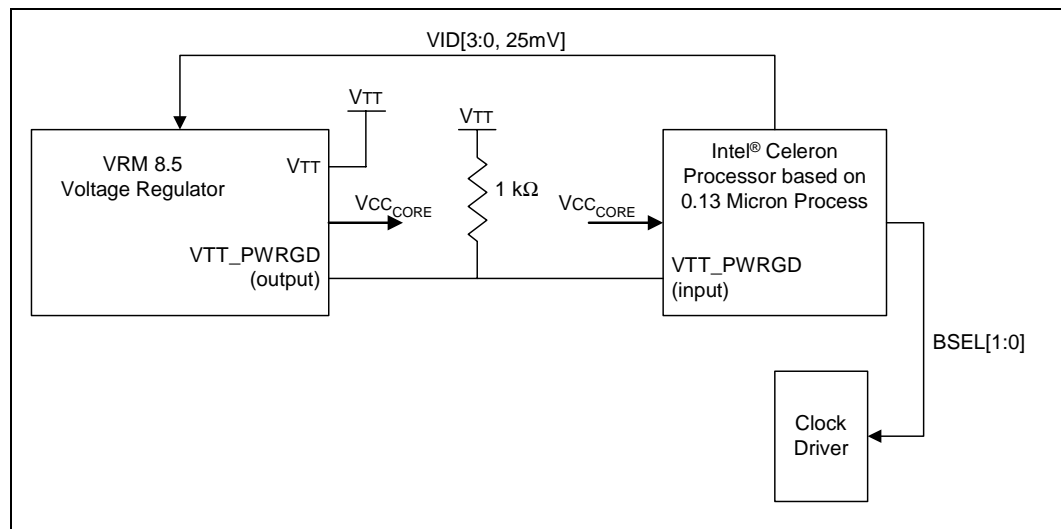

## 2.7 Processor System Bus Unused Pins

All RESERVED pins must remain unconnected unless specifically noted. Connection of these pins to  $V_{CC_{CORE}}$ ,  $V_{REF}$ ,  $V_{SS}$ ,  $V_{TT}$  or to any other signal (including each other) can result in component malfunction or incompatibility with future processors. See Section 5.4 for a pin listing of the processor and the location of each RESERVED pin.

PICCLK must be driven with a valid clock input and the PICD[1:0] signals must be pulled-up to  $V_{CC_{CMOS1.5}}$  even when the APIC will not be used. A separate pull-up resistor must be provided for each PICD signal.

For reliable operation, always connect unused inputs or bidirectional signals to their deasserted signal level. The pull-up or pull-down resistor values are system dependent and should be chosen such that the logic high ( $V_{IH}$ ) and logic low ( $V_{IL}$ ) requirements are met. See Table 11 for level specifications of non-AGTL signals.

For unused AGTL inputs, the on-die termination will be sufficient. No external  $R_{TT}$  is necessary on the motherboard

For unused CMOS inputs, active low signals should be connected through a pull-up resistor to  $V_{CC_{CMOS1.5}}$  and meet  $V_{IH}$  requirements. Unused active high CMOS inputs should be connected through a pull-down resistor to ground ( $V_{SS}$ ) and meet  $V_{IL}$  requirements. Unused CMOS outputs can be left unconnected. A resistor must be used when tying bidirectional signals to power or ground. When tying any signal to power or ground, a resistor will also allow for system testability.

## 2.8 Processor System Bus Signal Groups

To simplify the following discussion, the processor system bus signals have been combined into groups by buffer type. All P6 family processor system bus outputs are open drain and require a high-level source provided termination resistors. However, the processor includes on-die termination for AGTL signals and termination resistors placed on the platform are not necessary except for the RESET# signal which still requires external termination.

AGTL input signals have differential input buffers which use  $V_{REF}$  as a reference signal. AGTL output signals require termination to 1.25 V. In this document, the term “AGTL Input” refers to the AGTL input group as well as the AGTL I/O group when receiving. Similarly, “AGTL Output” refers to the AGTL output group as well as the AGTL I/O group when driving.

The PWRGOOD signal input is a 1.8 V signal level and must be pulled up to  $V_{CC_{CMOS1.8}}$ . The VTT\_PWRGD is **not** 1.8 V tolerant and must be connected to VTT (1.25 V). Other CMOS inputs (A20M#, IGNNE#, INIT#, LINT0/INTR, LINT1/NMI, PREQ#, SMI, SLP#, and STPCLK#) are only 1.5 V tolerant and must be pulled up to  $V_{CC_{CMOS1.5}}$ . The CMOS, APIC, and TAP outputs are open drain and must be pulled to the appropriate level to meet the input specifications of the interfacing device.

The groups and the signals contained within each group are shown in [Table 4](#). Refer to [Section 7.0](#) for a description of these signals.

**Table 4. System Bus Signal Groups <sup>1</sup>**

Group Name	Signals
AGTL Input	BPRI#, DEFER#, RESET#, RSP#
AGTL Output	PRDY#
AGTL I/O	A[35:3]#, ADS#, AERR#, AP[1:0]#, BERR#, BINIT#, BNR#, BP[3:2]#, BPM[1:0]#, BR0# <sup>2</sup> , D[63:0]#, DBSY#, DEP[7:0]#, DRDY#, HIT#, HITM#, LOCK#, REQ[4:0]#, RP#, RS[2:0]#, TRDY#
CMOS Input (1.25 V) <sup>3</sup>	VTT_PWRGD
CMOS Input (1.5 V) <sup>4</sup>	A20M#, FLUSH#, IGNNE#, INIT#, LINT0/INTR, LINT1/NMI, PREQ#, SLP#, SMI#, STPCLK#
CMOS Input (1.8 V) <sup>5</sup>	PWRGOOD
CMOS Output (1.5 V) <sup>4</sup>	FERR#, IERR#, THERMTRIP#
CMOS Output <sup>8</sup> (3.3 V)	VID[3:0,25mV], BSEL[1:0]
System Bus Clock <sup>10</sup> (1.25 V/2.5 V)	BCLK0, BCLK0#
APIC Clock <sup>9</sup>	PICCLK
APIC I/O <sup>4</sup>	PICD[1:0]
TAP Input <sup>4</sup>	TCK, TDI, TMS, TRST#
TAP Output <sup>4</sup>	TDO
Power/Other <sup>6</sup>	CPUPRES#, DYN_OE, NCHTRL, PLL[2:1], SLEWCTRL, RTTCTRL <sup>7</sup> , THERMDN, THERMDP, VCC <sub>CORE</sub> , V <sub>REF</sub> , VSS, VTT, Reserved,

**NOTES:**

1. See [Section 7.0](#) for information on the these signals.
2. The BR0# pin is the only BREQ# signal that is bidirectional. See [Section 7.0](#) for more information.
3. This signal is 1.25 V.
4. These signals are 1.5 V.
5. This signal is 1.8 V.
6. VCC<sub>CORE</sub> is the power supply for the processor core and is described in [Section 2.6](#). VID[3:0,25mV] is described in [Section 2.6](#). VTT is used to terminate the system bus and generate V<sub>REF</sub> on the motherboard. VSS is system ground. BSEL[1:0] is described in [Section 2.8.2](#) and [Section 7.0](#). All other signals are described in [Section 7.0](#).
7. This signal is used to control the value of the processor on-die termination resistance. Refer to the platform design guide for the recommended pulldown resistor value.
8. These signals are 3.3 V.
9. These signals are 2.0 V.
10. 1.25 V signal for Differential clock application and 2.5 V for Single-ended clock application.

### 2.8.1 Asynchronous vs. Synchronous for System Bus Signals

All AGTL signals are synchronous to BCLK (BCLK/BCLK#). All of the CMOS, Clock, APIC, and TAP signals can be applied asynchronously to BCLK (BCLK/BCLK#). All APIC signals are synchronous to PICCLK. All TAP signals are synchronous to TCK.

## 2.8.2 System Bus Frequency Select Signals

The System Bus Frequency Select Signals (BSEL [1:0]) are used to select the system bus frequency for the processor. The BSEL signals are also used by the chipset and system bus clock generator. The BSEL pins for the processor are open drain signals versus opens or shorts found on the previous Intel Celeron FC-PGA processor. Refer to [Table 11](#) for level specifications for the BSEL signals.

The BSEL signals rely on a 3.3 V pull-up resistor to set the signal to a logic high level. Similar to the VID signals described in [Section 2.6](#), the VTT\_PWRGD signal also informs the platform that the BSEL signals are stable and should be sampled. During Power-up, the BSEL signals will be in an indeterminate state for a small period of time. The chipset or system bus clock generator should not sample and/or latch the BSEL signals until the VTT\_PWRGD signal is asserted. The assertion of the VTT\_PWRGD signal indicates the BSEL signals are stable and are driven to the final state by the processor. Refer to [Figure 14](#) for power-up timing sequence for the VTT\_PWRGD and the BSEL signals.

[Table 5](#) defines the possible combinations of the BSEL signals and the frequency associated with each combination. The frequency selection is determined by the processor(s) and driven out to the chipset and system bus clock generator. All system bus agents must operate at the same frequency determined by the processor. The processor operates at 100 MHz system bus frequency based on the system bus specified rating marked on the package. Over or under-clocking the system bus frequency outside the specified rating marked on the package is not recommended.

**Figure 7. BSEL[1:0] Example for a System Design**

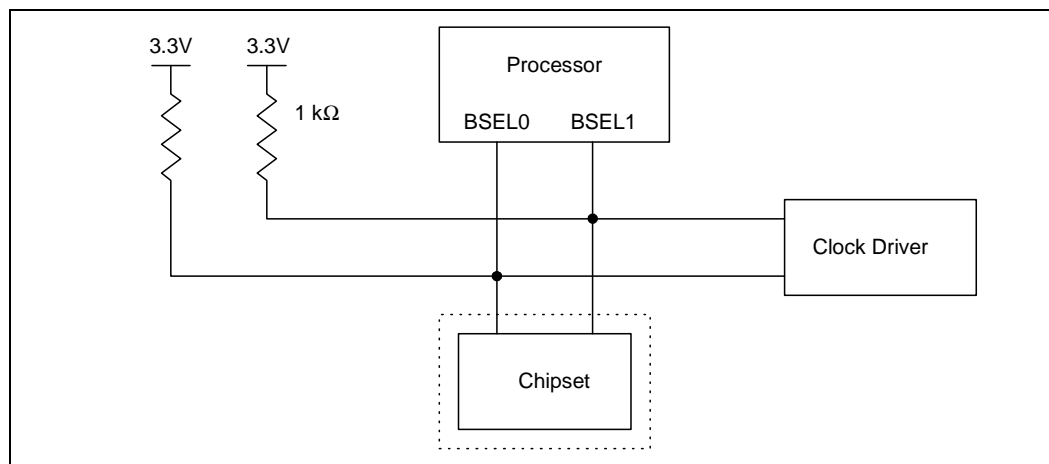

**Table 5. Frequency Select Truth Table for BSEL[1:0]**

BSEL1	BSEL0	Frequency
0	0	Reserved
0	1	100 MHz
1	0	Reserved
1	1	Reserved



## 2.9 Test Access Port (TAP) Connection

Due to the voltage levels supported by other components in the Test Access Port (TAP) logic, it is recommended that the processor be first in the TAP chain and followed by any other components within the system. A translation buffer should be used to connect to the rest of the chain unless one of the other components is capable of accepting an input of the appropriate voltage. Similar considerations must be made for TCK, TMS, and TRST#. Two copies of each signal may be required with each driving a different voltage level.

## 2.10 Maximum Ratings

Table 6 contains processor stress ratings only. Functional operation at the absolute maximum and minimum is not implied nor guaranteed. The processor should not receive a clock while subjected to these conditions. Functional operating conditions are given in the timing and level tables in Section 2.11 through Section 2.13. Extended exposure to the maximum ratings may affect device reliability. Furthermore, although the processor contains protective circuitry to resist damage from static electric discharge, one should always take precautions to avoid high static voltages or electric fields.

**Table 6. Absolute Maximum Ratings**

Symbol	Parameter	Min	Max	Unit	Notes
T <sub>STORAGE</sub>	Processor storage temperature	-40	85	°C	
V <sub>CC</sub> <sub>CORE</sub> and V <sub>TT</sub>	Processor core voltage and termination supply voltage with respect to V <sub>SS</sub>	0.5	1.75	V	
V <sub>in</sub> <sub>AGTL</sub>	AGTL buffer input voltage	-0.3	1.78	V	1, 3
V <sub>in</sub> <sub>CMOS1.5</sub>	CMOS buffer DC input voltage with respect to V <sub>SS</sub>	-0.3	2.08	V	2, 3, 4
V <sub>VID</sub> & V <sub>BSEL</sub>	Max VID and BSEL pin current	-0.3	3.6	V	

**NOTES:**

1. Input voltage can never exceed V<sub>SS</sub> + 1.78 volts.
2. Input voltage can never exceed V<sub>SS</sub> + 2.08 volts.
3. Input voltage can never go below -0.3 V
4. Parameter applies to CMOS, APIC, and TAP bus signal groups only.

## 2.11 Processor Voltage Level Specifications

The processor voltage level specifications in this section are defined at the PGA370 socket pins (bottom side of the motherboard). See Section 7.0 for the processor signal descriptions and Section 5.4 for the signal listings.

Most of the signals on the processor system bus are in the AGTL signal group. These signals are specified to be terminated to 1.25 V. The voltage level specifications for these signals are listed in Table 10 on page 29.

To allow connection with other devices, the clock, CMOS, APIC, and TAP signals are designed to interface at non-AGTL levels. The voltage level specifications for these pins are listed in Table 11 on page 29.

Table 7 through Table 13 list the voltage level specifications for the processor. Specifications are valid only while meeting specifications for junction temperature, clock frequency, and input voltages. Care should be taken to read all notes associated with each parameter.

**Table 7. Voltage and Current Specifications (Sheet 1 of 2)**

Symbol	Parameter	Core Freq	Min	Typ	Max	Unit	Notes <sup>1,2</sup>
V <sub>CC</sub> CORE	V <sub>CC</sub> for processor core	1.4 GHz 1.30 GHz 1.20 GHz 1.20 <sup>14</sup> GHz 1.10A GHz 1A GHz 900 MHz		1.5 1.5 1.5 1.475 1.475 1.475 1.475		V	3, 13
V <sub>TT</sub>	Static AGTL bus termination voltage			1.25		V	1.25 ±3%, <sup>4</sup>
V <sub>TT</sub>	Transient AGTL bus termination voltage			1.25		V	1.25 ±9%, <sup>4</sup>
V <sub>CC</sub> _cmos1.5				1.5		V	1.5 ± 10%, <sup>12</sup>
V <sub>CC</sub> _cmos1.8				1.8		V	1.8 ± 10%, <sup>12</sup>
Baseboard V <sub>CC</sub> CORE Tolerance, Static	Processor core voltage static tolerance level at the PGA370 socket pins		Refer to Figure 8 and Table 9 for Tolerance values			V	5
Baseboard V <sub>CC</sub> CORE Tolerance, Transient	Processor core voltage transient tolerance level at the PGA370 socket pins					V	5
I <sub>CC</sub> CORE	I <sub>CC</sub> for processor core	1.4 GHz 1.30 GHz 1.20 GHz 1.20 <sup>14</sup> GHz 1.10A GHz 1A GHz 900 MHz			22.6 22.5 21.5 20.6 19.9 19.1 18.1	A	6, 13
I <sub>CC</sub> CMOS1.5	I <sub>CC</sub> for V <sub>CC</sub> CMOS1.5				250	mA	
I <sub>CC</sub> CMOS1.8	I <sub>CC</sub> for V <sub>CC</sub> CMOS1.8				1	mA	
I <sub>CC</sub> CMOS3.3	I <sub>CC</sub> for V <sub>CC</sub> CMOS3.3				35	mA	
I <sub>V</sub> TT	Termination voltage supply current				2.3	A	
I <sub>SGnt</sub>	I <sub>CC</sub> Stop-Grant for processor core				15.37	A	7, 8
I <sub>D</sub> SLP	I <sub>CC</sub> Deep Sleep	1.4 GHz 1.30 GHz 1.20 GHz 1.20 <sup>14</sup> GHz 1.1A GHz 1A GHz 900 MHz			12.0 12.0 12.0 11.0 11.0 11.0 11.0	A	
dl <sub>CC</sub> CORE/dt	Power supply current slew rate		Refer to Table 8 for Slew Rate			A/μs	8, 9, 10, 11

**Table 7. Voltage and Current Specifications (Sheet 2 of 2)**

Symbol	Parameter	Core Freq	Min	Typ	Max	Unit	Notes <sup>1, 2</sup>
$dl_{V_{TT}}/dt$	Termination current slew rate				Table 13	A/μs	8, 9, 10 See Table 13

**NOTES:**

1. Unless otherwise noted, all specifications in this table apply to all processor frequencies.
2. All specifications in this table apply only to the Celeron processor based on 0.13 micron process core.
3.  $V_{CC_{CORE}}$  and  $I_{CC_{CORE}}$  supply the processor core and the on-die L2 cache.
4.  $V_{TT}$  must be held to 1.25 V ±9% while the AGTL bus is active. It is required that  $V_{TT}$  be held to 1.25 V ±3% while the processor system bus is static (idle condition). The ±3% range is the required design target; ±9% will come from the transient noise added. This is measured at the PGA370 socket pins on the bottom side of the baseboard.
5. **These are the tolerance requirements, across a 20 MHz frequency bandwidth, measured at the processor socket pin on the soldered-side of the motherboard.**  $V_{CC_{CORE}}$  must return to within the static voltage specification within 100 μs after a transient event; see the *VRM 8.5 DC-DC Converter Design Guidelines* for further details.
6. Maximum  $I_{CC}$  is measured at  $V_{CC}$  typical voltage and under a maximum signal loading conditions.
7. The current specified is also for AutoHALT state.
8. Maximum values are specified by design/characterization at nominal  $V_{CC_{CORE}}$ .
9. Based on simulation and averaged over the duration of any change in current. Use to compute the maximum inductance tolerable and reaction time of the voltage regulator. This parameter is not tested.
10.  $dl_{CC}/dt$  specifications are measured and specified at the PGA370 socket pins.
11. Static voltage regulation includes: DC output initial voltage set point adjust, Output ripple and noise, Output load ranges specified in the tables above. See VRM 8.5 Specification.
12. Pull ups only.
13. For frequencies beyond 1.40 GHz, refer to the latest flexible motherboard 1 extended (FMB1-E) guidelines available via your Intel Representative.
14. 1.20 GHz at  $V_{CC_{CORE}} = 1.475$  volts and S-Spec number SL5XS.

**Table 8. Power Supply Current Slew Rate ( $dl_{CC_{CORE}}/dt$ )**

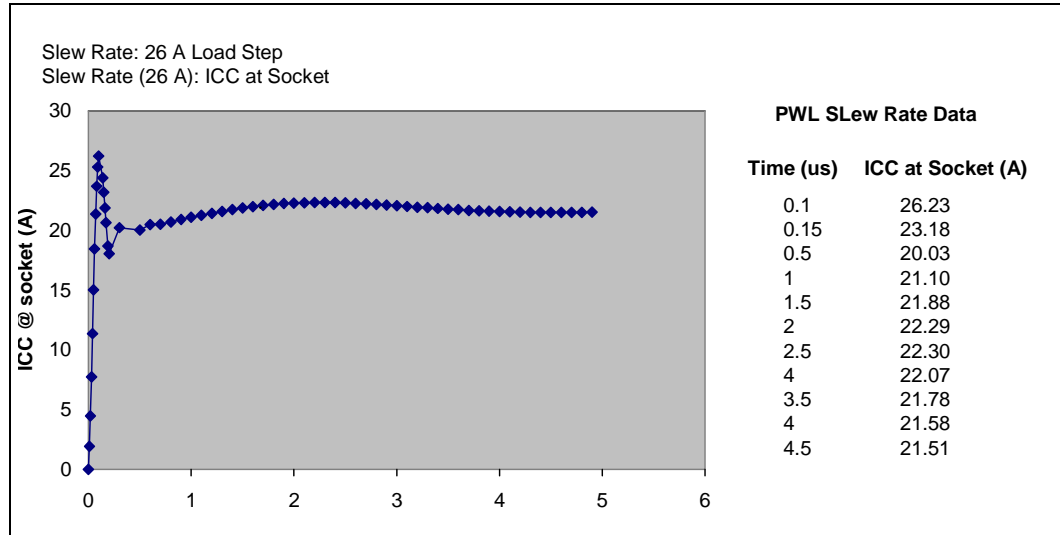
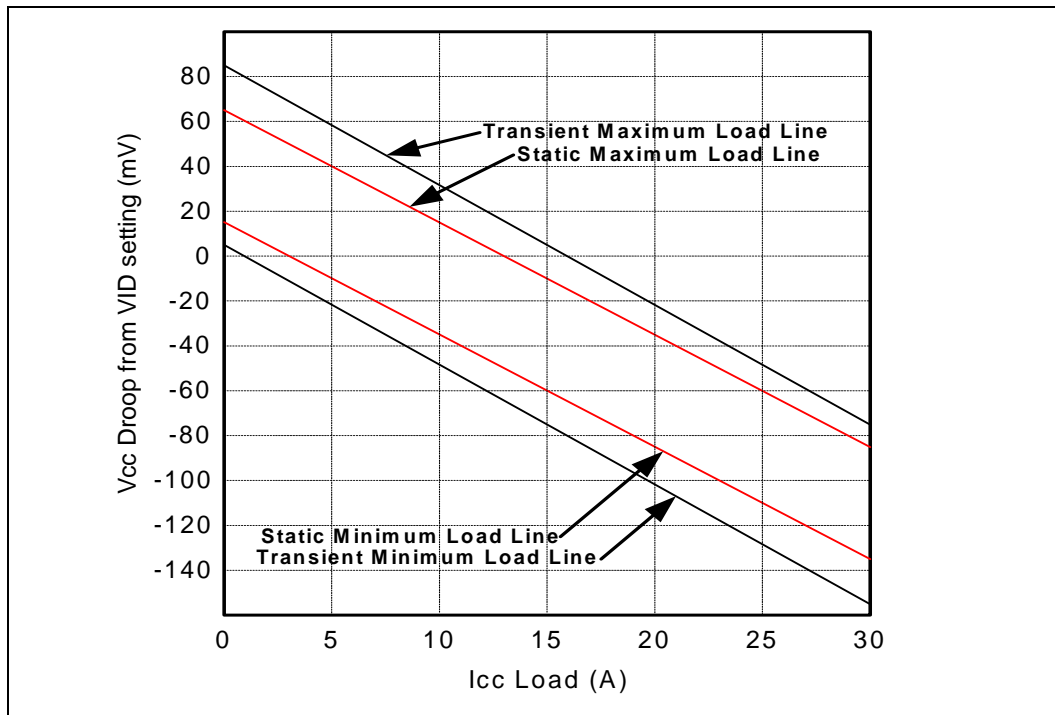

Table 8 contains typical slew rate data for the processor. Actual slew rate values and wave-shapes may vary slightly depending on the type and size of decoupling capacitors used in a particular implementation.

**Table 9. Vcc Static & Transient Tolerance**

Icc (A)	Voltage Deviation from VID Setting (mV)			
	Static Tolerance		Transient Tolerance	
	Min	Max	Min	Max
0	15	65	5	85
2	5	55	-5	74
4	-5	45	-15	62
6	-15	35	-25	51
8	-25	25	-35	40
10	-35	15	-45	28
12	-45	5	-55	17
14	-55	-5	-65	6
16	-65	-15	-76	-5
18	-75	-25	-87	-15
20	-85	-35	-98	-25
22	-95	-45	-110	-35
24	-105	-55	-121	-45
26	-115	-65	-132	-55
28	-125	-75	-144	-65
30	-135	-85	-155	-75

**Figure 8. Vcc Static and Transient Tolerance**



**Table 10. AGTL Signal Group Levels Specifications**

Symbol	Parameter	Min	Max	Unit	Notes <sup>1</sup>
V <sub>IL</sub>	Input Low Voltage		V <sub>REF</sub> - 0.200	V	6
V <sub>IH</sub>	Input High Voltage	V <sub>REF</sub> + 0.200		V	2, 3, 6
R <sub>on</sub>	Buffer On Resistance		16.67	Ω	5
I <sub>L</sub>	Leakage Current for inputs, outputs, and I/O		±100	μA	4, 7

**NOTES:**

1. Unless otherwise noted, all specifications in this table apply to the processor at a frequency up to 1.40 GHz on 0.13 micron.
2. All inputs, outputs, and I/O pins must comply with the signal quality specifications in [Section 3.0](#).
3. Minimum and maximum V<sub>TT</sub> are given in [Table 13 on page 30](#).
4. (0 ≤ V<sub>IN</sub> ≤ 1.25 V +3%) and (0 ≤ V<sub>OUT</sub> ≤ 1.25 V +3%).
5. Refer to the processor I/O Buffer Models for I/V characteristics.
6. Steady state input voltage must not be above V<sub>SS</sub> + 1.65 V or below V<sub>TT</sub> - 1.65 V.
7. Does not apply to V<sub>CC</sub> leakage current due to the presence of on-die RTT.

**Table 11. Non-AGTL Signal Group Levels Specifications**

Symbol	Parameter	Min	Max	Unit	Notes <sup>1</sup>
V <sub>IL1,2</sub>	Input Low Voltage		0.4	V	11
V <sub>IL1,5</sub>	Input Low Voltage	-0.150	V <sub>cmos_ref</sub> - 0.300	V	10
V <sub>IL1,8</sub>	Input Low Voltage	-0.36	0.36	V	8
V <sub>IL2,0</sub>	Input Low Voltage	-0.40	0.40	V	9
V <sub>IH1,2</sub>	Input High Voltage	1.03		V	11
V <sub>IH1,5</sub>	Input High Voltage	V <sub>cmos_ref</sub> + 0.250	V <sub>CC_CMOS1.5</sub> + 10%	V	6, 10, 12
V <sub>IH1,5PICD</sub>	Input High Voltage PICD[1:0]	V <sub>cmos_ref</sub> + 0.200	2.0	V	12, 13
V <sub>IH1,8</sub>	Input High Voltage	1.44	2.16	V	8
V <sub>IH2,0</sub>	Input High Voltage	1.60		V	9
R <sub>on</sub>			30	Ω	2
V <sub>OL</sub>	Output Low Voltage		0.30	V	7, 9, All outputs are open-drain
I <sub>OL</sub>	Output Low Current		10	mA	
I <sub>LI</sub>	Input Leakage Current		±100	μA	3, 6
I <sub>LO</sub>	Output Leakage Current		±100	μA	3, 4, 6, 7

**NOTES:**

1. Unless otherwise noted, all specifications in this table apply to the processor up to 1.40 GHz frequency on 0.13 micron.
2. Parameter measured at 9 mA (for use with TTL inputs).
3. (0 ≤ V<sub>IN</sub> ≤ 1.8 V +10%).
4. (0 ≤ V<sub>OUT</sub> ≤ 1.8 V +10%).
5. For BCLK specifications, refer to [Table 24 on page 41](#).
6. (0 ≤ V<sub>IN</sub> ≤ 1.5 V +10%).
7. (0 ≤ V<sub>OUT</sub> ≤ 1.5 V +10%).
8. Applies to non-AGTL signal PWRGOOD.
9. Applies to non-AGTL signal PICCLK.
10. Applies to non-AGTL signals **except** BCLK, PICCLK, and PWRGOOD.
11. Applies to non-AGTL signal VTT\_PWRGD.
12. V<sub>cmos\_ref</sub> = 2/3 V<sub>CC\_CMOS1.5</sub>, refer to [Table 7 on page 26](#).
13. Applies to PICD[1:0] only

Table 12. 3.3 Volt CMOS Output Signal Group DC Specifications

Symbol	Parameter	Min	Max	Unit	Notes
V	Nominal Voltage		3.45	V	3.3 + 5%
V <sub>OH</sub>	Output High Voltage		0.9	V	
I <sub>LO</sub>	Output Leakage Current		100	μA	

## 2.12 AGTL System Bus Specifications

It is recommended that the AGTL bus be routed in a daisy-chain fashion with termination resistors to V<sub>TT</sub>. These termination resistors are placed electrically between the ends of the signal traces and the V<sub>TT</sub> voltage supply. The valid high and low levels are determined by the input buffers using a reference voltage called V<sub>REF</sub>. Refer to the appropriate platform design guide for more information.

Table 13 lists the nominal specification for the AGTL termination voltage (V<sub>TT</sub>). The AGTL reference voltage (V<sub>REF</sub>) is generated on the system motherboard and should be set to 2/3 V<sub>TT</sub> for the processor and other AGTL logic. It is important that the baseboard impedance be specified and held to a ±15% tolerance, and that the intrinsic trace capacitance for the AGTL signal group traces is known and well-controlled. For more details on the AGTL buffer specification, see the *Intel® Pentium® II Processor Developer's Manual* and AP-585, *Intel® Pentium® II Processor AGTL Guidelines*.

Table 13. Processor AGTL Bus Specifications

Symbol	Parameter	Min	Typ	Max	Units	Notes <sup>1,2</sup>
V <sub>TT</sub>	Bus Termination Voltage	1.1375	1.25		V	3
On-die R <sub>TT</sub>	Termination Resistor	50	56 68	115	Ω	4
V <sub>REF</sub>	Bus Reference Voltage		2/3V <sub>TT</sub>		V	5

### NOTES:

1. Unless otherwise noted, all specifications in this table apply to the processor up to 1.40 GHz frequency.
2. The processor for the PGA370 socket contain AGTL termination resistors on the processor die, except for the RESET# input.
3. V<sub>TT</sub> must be held to 1.25 V ±9%. It is required that V<sub>TT</sub> be held to 1.25 V ±3% while the processor system bus is idle (static condition). This is measured at the PGA370 socket pins on the bottom side of the baseboard.
4. Uni-processor platforms require a 56 Ω resistor and dual-processor platforms require a 68Ω resistor. Tolerance for on-die R<sub>tt</sub> is ±10% (56 Ω, 68 Ω resistors). R<sub>tt</sub> is ±15% (100 Ω resistors).
5. V<sub>REF</sub> is generated on the motherboard and should be 2/3 V<sub>TT</sub> ±5% nominally. Insure that there is adequate V<sub>REF</sub> decoupling on the motherboard.

## 2.13 System Bus Timing Specifications

The processor system bus timings specified in this section are defined at the socket pins on the bottom of the motherboard. Unless otherwise specified, timings are tested at the processor pins during manufacturing. Timings at the processor pins are specified by design characterization. See [Section 7.0](#) for the processor signal definitions.

[Table 14](#) through [Table 21](#) list the timing specifications associated with the processor system bus. These specifications are broken into the following categories: [Table 14](#) contains the system bus clock specifications for Single-ended clock mode operation and [Table 15](#) contains the system bus clock specifications for Differential clock mode operation. [Table 17](#) contains the AGTL specifications, [Table 18](#) contains the CMOS signal group specifications, [Table 19](#) contains timings for the reset conditions, [Table 20](#) and covers APIC bus timing, and [Table 21](#) covers TAP timing.

All processor system bus timing specifications for the AGTL signal group are relative to the rising edge of the BCLK input. All AGTL timings are referenced to  $V_{REF}$  for both '0' and '1' logic levels unless otherwise specified..

AGTL layout guidelines are also available in the appropriate platform design guide. Care should be taken to read all notes associated with a particular timing parameter.

**Table 14. System Bus Timing Specifications (Single-Ended Clock)**

T# Parameter	100 MHz		Unit	Figure	Notes <sup>1,4</sup>
	Min	Max			
T1: BCLK Period - average	10.0	10.15	nS	9	2
T1 <sub>abs</sub> : BCLK Period - Instantaneous minimum	9.75		nS		2
T2: BCLK Period Stability		250	pS		2
T5: BCLK Rise Time	0.4	1.6	nS	10	3
T6: BCLK Fall Time	0.4	1.6	nS	10	3
T3: BCLK High Time	2.5		nS	10	5
T4: BCLK Low Time	2.4		nS	10	6
T7: BCLK Input High	2.2		V		
T8: BCLK Input Low		0.3	V		

**NOTES:**

1. Unless otherwise noted, all specifications in this table apply to the processor up to 1.40 GHz frequency on 0.13 micron process.
2. Period, jitter, offset and skew measured at 1.25 V.
3. Measured from 0.5 to 2.0 V.
4. CLKREF (BCLK#) = 1.25 V with ±5% DC tolerance. CLKREF must be generated from a stable source. AC tolerances must be less than -40 dB at 1 MHz.
5. BCLK High Time is measured above 2.0 V.
6. BCLK Low Time is measured below 0.5 V.

Table 15. System Bus Timing Specifications (Differential Clock)

T# Parameter	100 MHz		Unit	Figure	Notes <sup>1,2,6</sup>
	Min	Max			
T1: BCLK Period - average	10.0	10.2	nS	9	3, 4
T1 <sub>abs</sub> : BCLK Period - Instantaneous minimum	9.8		nS		3, 4
T2: BCLK Period Stability		200	pS		5
Vcross: Crossing point at 1V Swing	0.51	0.76	V	9	
T5: BCLK Rise Time	175	550	pS	10	7, 8
T6: BCLK Fall Time	175	550	pS	10	7, 8
Rise/Fall Time Matching		325	pS		
BCLK Duty Cycle	45%	55%			4
Input High Voltage	0.92	1.45	V		
Input Low Voltage	-0.2	0.35	V		
Rising Edge Ring Back	0.35		V		
Falling Edge Ring Back		-0.35	V		

1. Unless otherwise noted, all specifications in this table apply to the processor up to 1.40 GHz frequency on 0.13 micron process.
2. All timings for the AGTL signals are referenced at the rising edge of BCLK and the falling edge of BCLK# at the processor pin. All AGTL signal timings (address bus, data bus, etc.) are referenced at 1.00 V at the processor pins.
3. The internal core clock frequency is derived from the processor system bus clock. The system bus clock to core clock ratio is determined during initialization. Individual processors will only operate at their specified system bus frequency, 100 MHz. Table 16 shows the supported ratios for each processor.
4. Due to the difficulty of accurately measuring clock jitter in a system, it is recommended that a clock driver be used that is designed to meet the period stability specification into a test load of 10 to 20 pF. This should be measured at adjacent crossing points of BCLK and BCLK# which is defined as the rising edge of BCLK and the falling edge of BCLK# at the processor pin. The jitter present must be accounted for as a component of BCLK timing skew between devices.
5. The clock driver's closed loop jitter bandwidth must be set low to allow any PLL-based device to track the jitter created by the clock driver. The -20 dB attenuation point, as measured into a 10 to 20 pF load, should be less than 500 kHz. This specification may be ensured by design characterization and/or measured with a spectrum analyzer. See the appropriate clock synthesizer/driver specification for details.
6. Measurement taken from differential waveform, defined as BCLK - BCLK#.
7. Rise time is measured from -0.35 to +0.35V and fall time is measured from 0.35 V to -0.35 V.
8. Measured at the socket pin.



**Table 16. Valid System Bus to Core Frequency Ratios** <sup>1, 2, 3</sup>

Processor	Core Frequency	BCLK Frequency (MHz)	Frequency Multiplier
1.4 GHz	1.40	100	14
1.30	1.30 GHz	100	13
1.20	1.20 GHz	100	12
1.20 <sup>4</sup>	1.20 <sup>4</sup> GHz	100	12
1.1A	1.1A GHz	100	11
1A	1A GHz	100	10
900	900 MHz	100	9

**NOTES:**

1. Contact your local Intel representative for the latest information on processor frequencies and/or frequency multipliers.
2. While other bus ratios are defined, operation at frequencies other than those listed are not supported by the processor.
3. Individual processors will only operate at their specified system bus frequency; 100 MHz.
4. 1.20 GHz at V<sub>CC</sub>CORE = 1.475 volts and S-Spec number SL5XS.

**Table 17. System Bus Timing Specifications (AGTL Signal Group)**

T# Parameter	Min	Max	Unit	Figure	Notes <sup>1,2,3</sup>
T7: AGTL Output Valid Delay	0.40	3.25	ns	11	4
T8: AGTL Input Setup Time	1.30		ns	12	5, 6, 7, 10
T9: AGTL Input Hold Time	1.00		ns	12	8
T10: RESET# Pulse Width	1.00		ms	13	6, 9

**NOTES:**

1. Unless otherwise noted, all specifications in this table apply to the processor up to 1.40 GHz on 0.13 micron process.
2. These specifications are tested during manufacturing.
3. All timings for the AGTL signals are referenced to the rising edge of BCLK and the falling edge of BCLK# at the processor pin. All AGTL signal timings (compatibility signals, etc.) are referenced at 0.80 V at the processor pins.
4. Valid delay timings for these signals are specified into 50 Ω to 1.25 V, V<sub>REF</sub> at 0.8 V ±2% and with 56 Ω or 68 Ω on-die R<sub>TT</sub>.
5. A minimum of 3 clocks must be guaranteed between two active-to-inactive transitions of TRDY#.
6. RESET# can be asserted (active) asynchronously, but must be deasserted synchronously.
7. Specification is for a minimum 0.40 V swing from V<sub>REF</sub> – 200 mV to V<sub>REF</sub> + 200 mV. This assumes an edge rate of 0.3V/ns.
8. Specification is for a maximum 0.8 V swing from V<sub>TT</sub> – 0.8V to V<sub>TT</sub>. This assumes an edge rate of 3 V/ns.
9. This should be measured after V<sub>CC</sub>CORE, V<sub>TT</sub>, V<sub>CC</sub>CMOS, and BCLK (and BCLK#) are stable
10. BREQ signals observe a 1.2 ns minimum setup time.

**Table 18. System Bus Timing Specifications (CMOS Signal Group)**

T# Parameter	Min	Max	Unit	Figure	Notes <sup>1,2,3,4</sup>
T14: CMOS Input Pulse Width, except PWRGOOD	2		BCLKs	11	Active and Inactive states
T15: PWRGOOD Inactive Pulse Width	10		BCLKs	15	5

**NOTES:**

1. Unless otherwise noted, all specifications in this table apply to the processor up to 1.40 GHz frequency
2. These specifications are tested during manufacturing.
3. These signals may be driven asynchronously.

4. All CMOS outputs shall be asserted for at least 2 system bus clocks.
5. When driven inactive or after  $V_{CC_{CORE}}$ ,  $V_{TT}$ ,  $V_{CC_{CMOS}}$ , and BCLK and BCLK# are stable.

**Table 19. System Bus Timing Specifications (Reset Conditions) <sup>1</sup>**

T# Parameter	Min	Max	Unit	Figure	Notes
T16: Reset Configuration Signals (A[14:5]#, BR0#, INIT#) Setup Time	4		BCLKs	13	Before deassertion of RESET#
T17: Reset Configuration Signals (A[14:5]#, BR0#, INIT#) Hold Time	2	20	BCLKs	13	After clock that deasserts RESET#

**NOTE:**

1. Unless otherwise noted, all specifications in this table apply to all the processor up to 1.40 GHz frequency.

**Table 20. System Bus Timing Specifications (APIC Clock and APIC I/O) <sup>1, 2, 3</sup>**

T# Parameter	Min	Max	Unit	Figure	Notes
T21: PICCLK Frequency	2.0	33.3	MHz		
T22: PICCLK Period	30.0	500.0	ns	10	
T23: PICCLK High Time	10.5		ns	10	@ > 1.60 V
T24: PICCLK Low Time	10.5		ns	10	@ < 0.40 V
T25: PICCLK Rise Time	0.25	3.0	ns	10	(0.40 V – 1.60 V)
T26: PICCLK Fall Time	0.25	3.0	ns	10	(1.60 – 0.40 V)
T27: PICD[1:0] Setup Time	8.0		ns	12	4
T28: PICD[1:0] Hold Time	2.5		ns	12	4
T29a: PICD[1:0] Valid Delay (Rising Edge)	1.5	8.7	ns	11	4, 5, 6
T29b: PICD[1:0] Valid Delay (Falling Edge)	1.5	12.0	ns	10	4, 5, 6

**NOTES:**

1. Unless otherwise noted, all specifications in this table apply to the processor up to 1.40 GHz frequency.
2. These specifications are tested during manufacturing.
3. All timings for the APIC I/O signals are referenced to the PICCLK rising edge at 0.9 V at the processor pins. All APIC I/O signal timings are referenced at 1.0 V at the processor pins.
4. Referenced to PICCLK rising edge.
5. For open drain signals, valid delay is synonymous with float delay.
6. Valid delay timings for these signals are specified into 150 Ω load pulled up to 1.5 V.

**Table 21. System Bus Timing Specifications (TAP Connection)**

T# Parameter	Min	Max	Unit	Figure	Notes <sup>1,2,3</sup>
T30: TCK Frequency		16.667	MHz		
T31: TCK Period	60.0		ns	10	
T32: TCK High Time	25.0		ns	10	V <sub>cmos_ref</sub> + 0.200 V, 10
T33: TCK Low Time	25.0		ns	10	V <sub>cmos_ref</sub> - 0.200 V, 10
T34: TCK Rise Time		5.0	ns	10	(V <sub>cmos_ref</sub> - 0.200 V) - (V <sub>cmos_ref</sub> + 0.200 V), 4, 10
T35: TCK Fall Time		5.0	ns	10	(V <sub>cmos_ref</sub> + 0.200 V) - (V <sub>cmos_ref</sub> - 0.200 V), 4, 10
T36: TRST# Pulse Width	40.0		ns	17	Asynchronous, 10
T37: TDI, TMS Setup Time	5.0		ns	16	5
T38: TDI, TMS Hold Time	14.0		ns	16	5
T39: TDO Valid Delay	1.0	10.0	ns	16	6, 7
T40: TDO Float Delay		25.0	ns	16	6, 7, 10
T41: All Non-Test Outputs Valid Delay	2.0	25.0	ns	16	6, 8, 9
T42: All Non-Test Inputs Setup Time		25.0	ns	16	6, 8, 9, 10
T43: All Non-Test Inputs Setup Time	5.0		ns	16	5, 8, 9
T44: All Non-Test Inputs Hold Time	13.0		ns	16	5, 8, 9

**NOTES:**

1. Unless otherwise noted, all specifications in this table apply to the processor up to 1.40 GHz frequency.
2. All timings for the TAP signals are referenced to the TCK rising edge at 1.0 V at the processor pins. All TAP signal timings (TMS, TDI, etc.) are referenced at 1.0 V at the processor pins.
3. These specifications are tested during manufacturing, unless otherwise noted.
4. 1 ns can be added to the maximum TCK rise and fall times for every 1 MHz below 16.667 MHz.
5. Referenced to TCK rising edge.
6. Referenced to TCK falling edge.
7. Valid delay timing for this signal is specified to 1.5 V.
8. Non-Test Outputs and Inputs are the normal output or input signals (besides TCK, TRST#, TDI, TDO, and TMS). These timings correspond to the response of these signals due to TAP operations.
9. During Debug Port operation, use the normal specified timings rather than the TAP signal timings.
10. Not 100% tested. Specified by design characterization.

**Table 22. Platform Power-On Timings**

T# Parameter	Min	Max	Unit	Figure	Notes <sup>2</sup>
T45: Valid Time Before VTT_PWRGD	1.0		mS	14	1
T46: Valid Time Before PWRGOOD	2.0		mS	14	1
T47: RESET# Inactive to Valid Outputs	1		BCLK	14	1
T48: RESET# Inactive to Drive Signals	4		BCLK	14	1

**NOTES:**

1. All signals, during their invalid states, must be guarded against spurious levels from effecting the platform during processor power-up sequence.
2. Configuration Input signals include: A[14:5], BR0#, INIT#. For timing of these signals, refer to Table 18 and Figure 13.

**Notes:** For Figure 9 through Figure 19, the following apply:

1. Figure 9 through Figure 19 are to be used in conjunction with Table 14 through Table 21.
2. All timings for the AGTL signals at the processor pins are referenced to the rising edge of BCLK and the falling edge of BCLK# at the crossing point for differential clock mode and to the rising edge of BCLK at BCLK<sub>VREF</sub> (1.25 V) for single-ended clock mode. All AGTL signal timings (address bus, data bus, etc.) are referenced at 2/3V<sub>TT</sub> at the processor pins.
3. All timings for the APIC I/O signals at the processor pins are referenced to the PICCLK rising edge at 0.9 V. All APIC I/O signal timings are referenced at 1.0 V at the processor pins.
4. All timings for the TAP signals at the processor pins are referenced to the TCK rising edge at 1.0 V. All TAP signal timings (TMS, TDI, etc.) are referenced at 1.0 V at the processor pins.

**Figure 9. Clock Waveform**

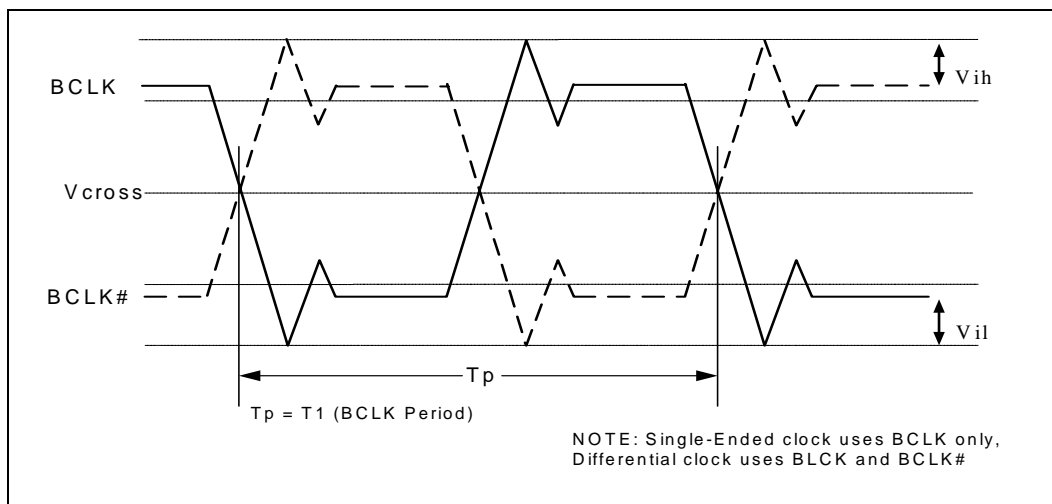

Figure 10. BCLK/BCLK#, PICCLK, and TCK Generic Clock Waveform

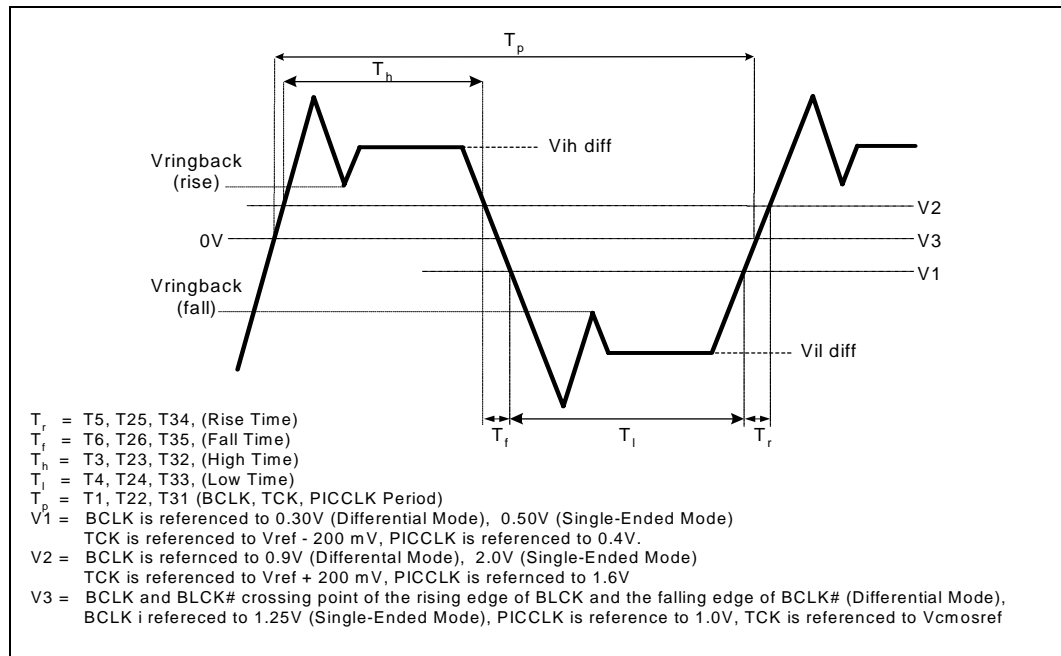

Figure 11. System Bus Valid Delay Timings

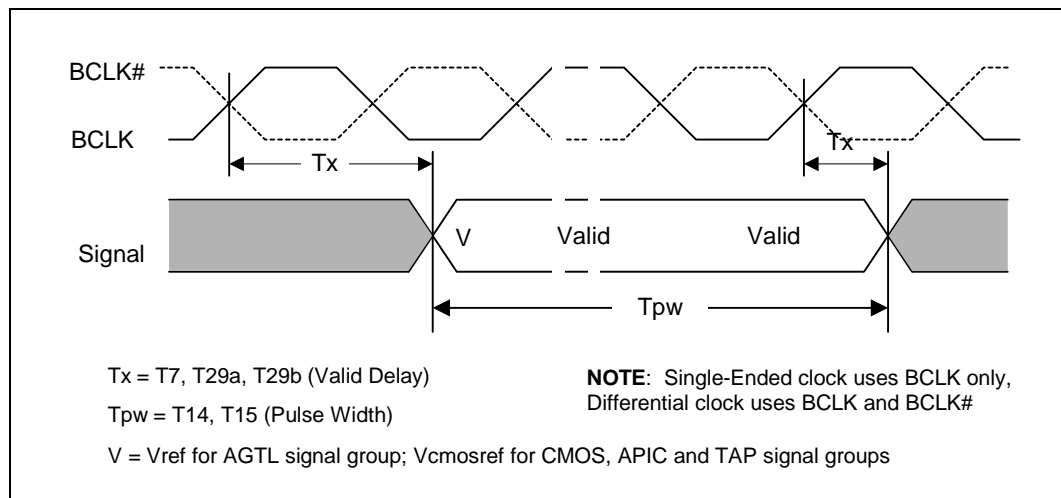

Figure 12. System Bus Setup and Hold Timings

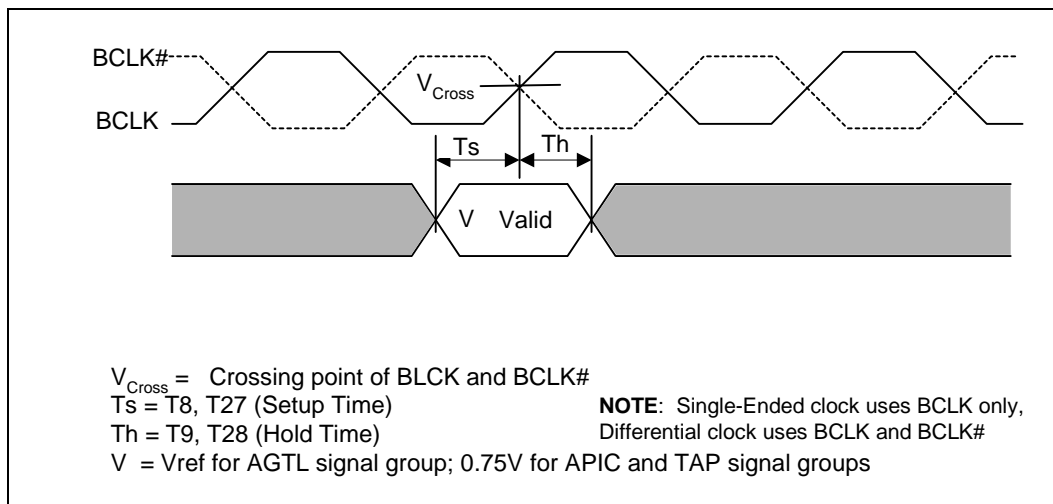

Figure 13. System Bus Reset and Configuration Timings

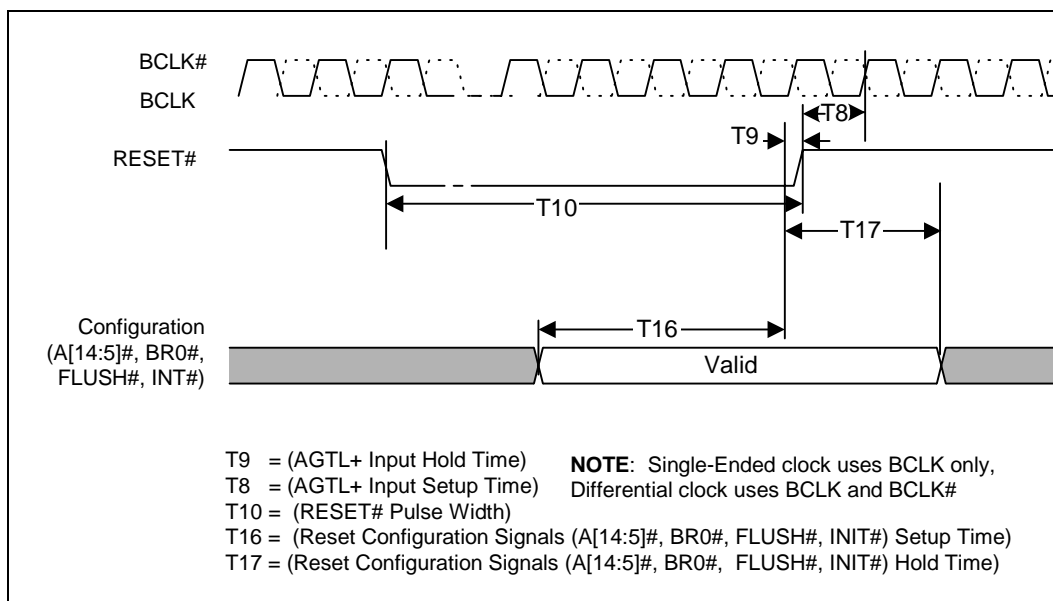

Figure 14. Platform Power-On Sequence and Timings

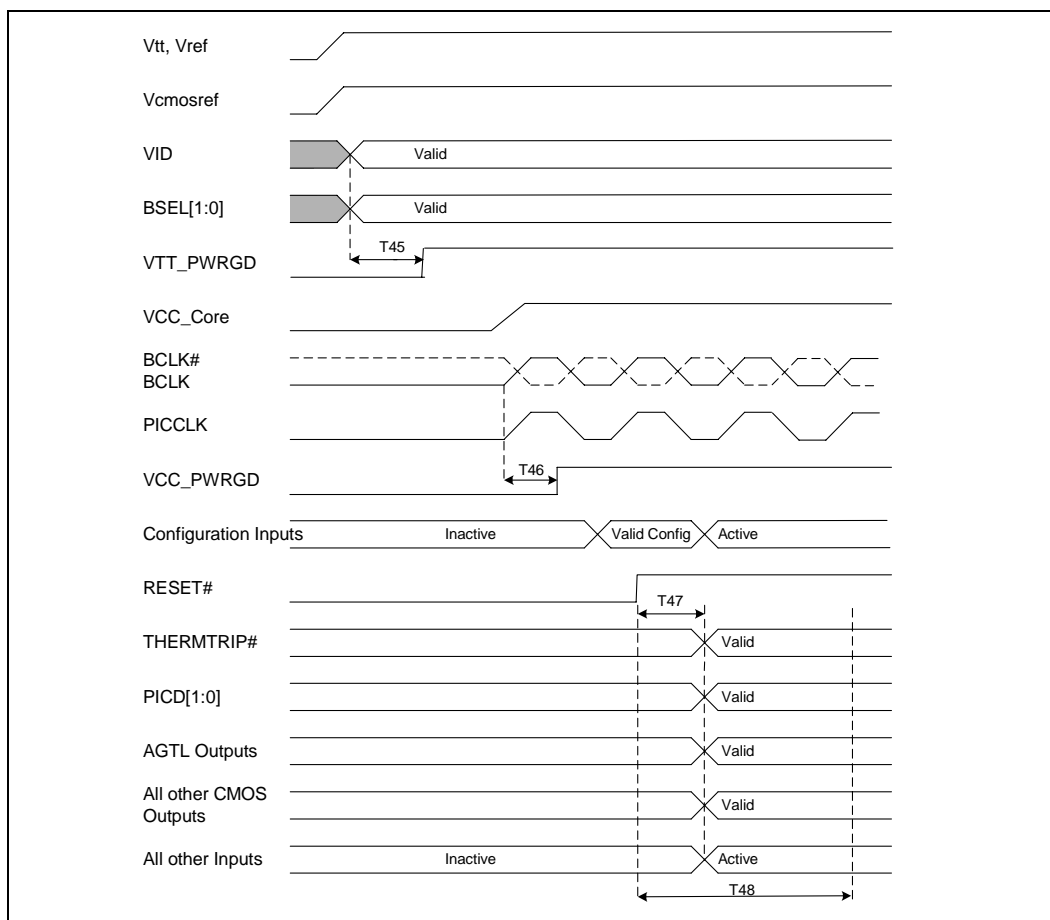

Figure 15. Power-On Reset and Configuration Timings

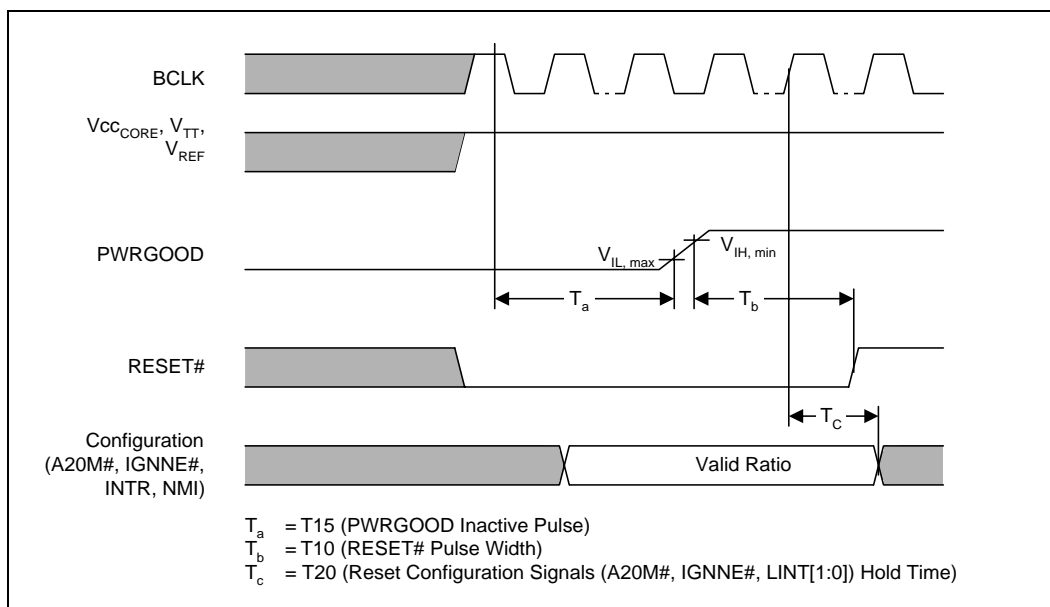

Figure 16. Test Timings (TAP Connection)

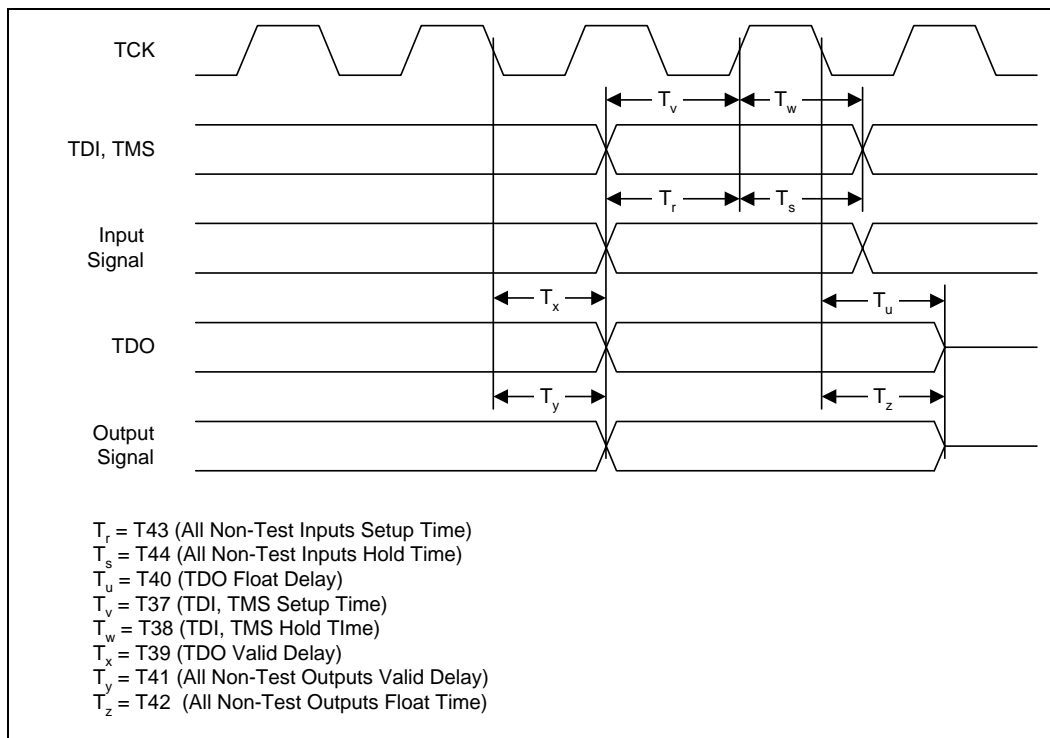
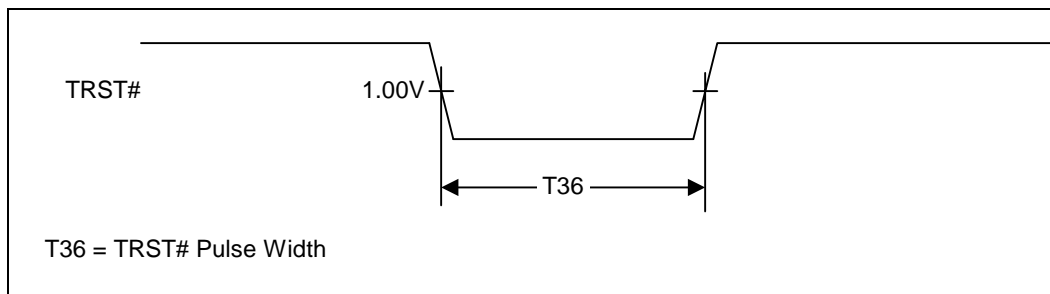

Figure 17. Test Reset Timings





### 3.0 Signal Quality Specifications

Signals driven on the processor system bus should meet signal quality specifications to ensure that the components read data properly and to ensure that incoming signals do not affect the long term reliability of the component. Specifications are provided for simulation at the processor pins. Meeting the specifications at the processor pins in Table 23, Table 24, and Table 27 ensures that signal quality effects will not adversely affect processor operation.

#### 3.1 BCLK/BCLK# & PICCLK Signal Quality Specifications and Measurement Guidelines

Table 24 describes the signal quality specifications at the processor pins for the processor system bus clock (BCLK/BCLK#) and APIC clock (PICCLK) signals. References made to BCLK signal quality specifications also applies to BCLK#. Figure 18 describes the signal quality waveform for the system bus clock at the processor pins.

**Table 23. BCLK (Single-Ended Clock Mode) Signal Quality Specifications for Simulation at the Processor Pins**

T# Parameter	Min	Nom	Max	Unit	Figure	Notes <sup>1</sup>
V1: BCLK V <sub>IL</sub>			0.3	V	18	
V2: BCLK V <sub>IH</sub>	2.2			V	18	
V3: BCLK Absolute Voltage Range	-0.5		3.1	V	18	
V4: BCLK Rising Edge Ringback	2.0			V	18	2
V5: BCLK Falling Edge Ringback			0.5	V	18	2

**Table 24. BCLK/BCLK# (Differential Clock Mode) and PICCLK Signal Quality Specifications for Simulation at the Processor Pins**

T# Parameter	Min	Nom	Max	Unit	Figure	Notes <sup>1</sup>
V1: BCLK V <sub>IL</sub>	-0.2		0.35	V	18	
V1: PICCLK V <sub>IL</sub>			0.40	V	18	
V2: BCLK V <sub>IH</sub>	0.92		1.45	V	18	
V2 PICCLK V <sub>IH</sub>	1.60			V	18	
V3: BCLK Absolute Voltage Range	-0.2		1.45	V	18	
V3: PICCLK Absolute Voltage Range	-0.4		2.4	V	18	
V4: BCLK Rising Edge Ringback	0.35			V	18	2
V4: PICCLK Rising Edge Ringback	1.60			V	18	2
V5: BCLK Falling Edge Ringback			-0.35	V	18	2
V5: PICCLK Falling Edge Ringback			0.40	V	18	2

**NOTES:**

1. Unless otherwise noted, all specifications in this table apply to the processor up to 1.40 GHz frequency.
2. The rising and falling edge ringback voltage specified is the minimum (rising) or maximum (falling) absolute voltage the BCLK/BCLK# and PICCLK signals can dip back to after passing the V<sub>IH</sub> (rising) or V<sub>IL</sub> (falling) voltage limits. This specification is an absolute value.

Figure 18. BCLK/BCLK#, PICCLK Generic Clock Waveform at the Processor Pins

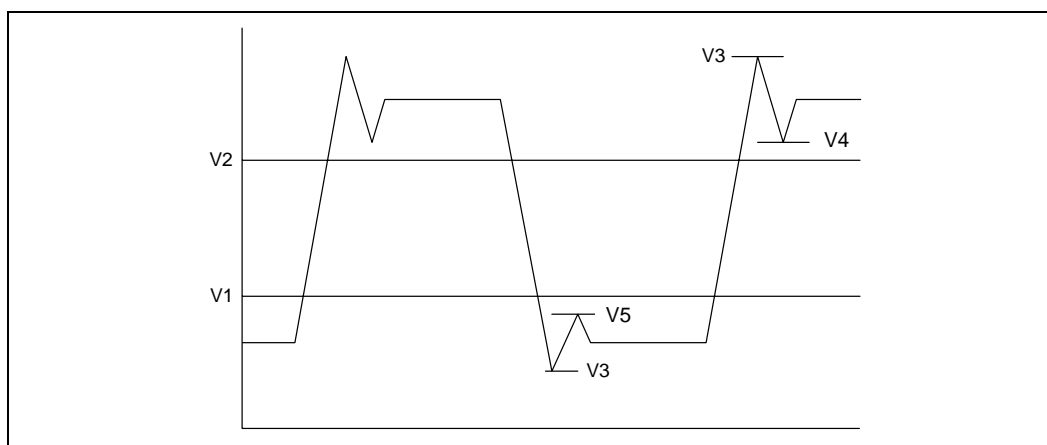

## 3.2 AGTL Signal Quality Specifications and Measurement Guidelines

Many scenarios have been simulated to generate a set of AGTL layout guidelines which are available in the appropriate platform design guide. Refer to the *Intel® Pentium® II Processor Developer's Manual* (Order Number 243502) for the AGTL buffer specification.

Table 25 provides the AGTL signal quality specifications for the processor for use in simulating signal quality at the processor pins.

The processor maximum allowable overshoot and undershoot specifications for a given duration of time are detailed in Table 24 through Table 26. Figure 19 shows the AGTL ringback tolerance and Figure 20 shows the overshoot/undershoot waveform.

Table 25. AGTL Signal Groups Ringback Tolerance Specifications at the Processor Pins

T# Parameter	Min	Unit	Figure	Notes 1,2,3
$\alpha$ : Overshoot	100	mV	19	4, 8
$\tau$ : Minimum Time at High	0.50	ns	19	
$\rho$ : Amplitude of Ringback	$\pm 200$	mV	19	5, 6, 7, 8
$\phi$ : Final Settling Voltage	200	mV	19	8
$\delta$ : Duration of Squarewave Ringback	N/A	ns	19	

### NOTES:

- Unless otherwise noted, all specifications in this table apply to the processor up to 1.40 GHz frequency.
- Specifications are for the edge rate of **0.3 – 3 V/ns**. See Figure 19 for the generic waveform.
- All values specified by design characterization.
- See Table 24 for maximum allowable overshoot.
- Ringback between  $V_{REF} + 100$  mV and  $V_{REF} + 200$  mV or  $V_{REF} - 300$  mV and  $V_{REF} - 100$  mVs requires the flight time measurements to be adjusted as described in the Intel AGTL Specifications. Ringback below  $V_{REF} + 100$  mV or above  $V_{REF} - 100$  mV is not supported.
- Intel recommends simulations not exceed a ringback value of  $V_{REF} \pm 200$  mV to allow margin for other sources of system noise.
- A negative value for  $\rho$  indicates that the amplitude of ringback is above  $V_{REF}$  (i.e.,  $\phi = -100$  mV specifies the signal cannot ringback below  $V_{REF} + 100$  mV).
- $\phi$  and  $\rho$  are measured relative to  $V_{REF}$ .  $\alpha$  is measured relative to  $V_{REF} + 200$  mV.

Figure 19. Low to High AGTL Receiver Ringback Tolerance

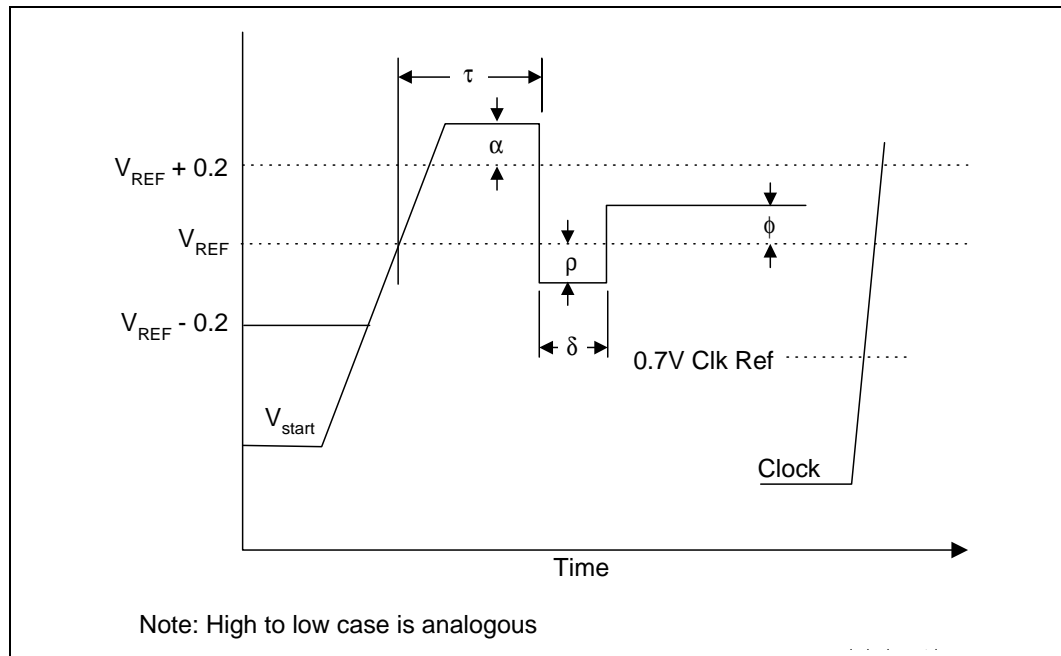

### 3.2.1 Overshoot/Undershoot Guidelines

Overshoot (or undershoot) is the absolute value of the maximum voltage above the nominal high voltage or below VSS. The overshoot guideline limits transitions beyond VCC or VSS due to the fast signal edge rates. The processor can be damaged by repeated overshoot events on 1.25 V or 2.5 V tolerant buffers if the charge is large enough (i.e., if the overshoot is great enough). Determining the impact of an overshoot/undershoot condition requires knowledge of the magnitude, the pulse direction and the activity factor (AF). Permanent damage to the processor is the likely result of excessive overshoot/undershoot. Violating the overshoot/undershoot guideline will also make satisfying the ringback specification difficult.

When performing simulations to determine impact of overshoot and undershoot, ESD diodes must be properly characterized. ESD protection diodes do not act as voltage clamps and will not provide overshoot or undershoot protection. ESD diodes modeled within Intel I/O Buffer models do not clamp undershoot or overshoot and will yield correct simulation results. If other I/O buffer models are being used to characterize the processor performance, care must be taken to ensure that ESD models do not clamp extreme voltage levels. Intel I/O Buffer models also contain I/O capacitance characterization. Therefore, removing the ESD diodes from an I/O Buffer model will impact results and may yield excessive overshoot/undershoot.

### 3.2.2 Overshoot/Undershoot Magnitude

Magnitude describes the maximum potential difference between a signal and its voltage reference level, VSS (overshoot) and VTT (undershoot). While overshoot can be measured relative to VSS using one probe (probe to signal and GND lead to VSS), undershoot must be measured relative to VTT. This could be accomplished by simultaneously measuring the VTT plane while measuring the signal undershoot. Today's oscilloscopes can easily calculate the true undershoot waveform. The true undershoot waveform can also be obtained with the following oscilloscope data file analysis:

$$\text{Converted Undershoot Waveform} = V_{TT} - \text{Signal}_{\text{measured}}$$

**Note:** The converted undershoot waveform appears as a positive (overshoot) signal.

**Note:** Overshoot (rising edge) and undershoot (falling edge) conditions are separate and their impact must be determined independently.

After the true waveform conversion, the undershoot/overshoot specifications shown in [Table 26](#) through [Table 29](#) can be applied to the converted undershoot waveform using the same magnitude and pulse duration specifications used with an overshoot waveform.

Overshoot/undershoot magnitude levels must observe the Absolute Maximum Specifications listed in [Table 26](#) through [Table 29](#). These specifications must not be violated at any time regardless of bus activity or system state. Within these specifications are threshold levels that define different allowed pulse durations. Provided that the magnitude of the overshoot/undershoot is within the Absolute Maximum Specifications (1.78 V AGTL, 2.08 V CMOS), the pulse magnitude, duration and activity factor must all be used to determine if the overshoot/undershoot pulse is within specifications.

### 3.2.3 Overshoot/Undershoot Pulse Duration

Pulse duration describes the total time an overshoot/undershoot event exceeds the overshoot/undershoot reference voltage ( $V_{os\_ref} = 1.32 \text{ V AGTL}, 1.80 \text{ V CMOS}$ ). The total time could encompass several oscillations above the reference voltage. Multiple overshoot/undershoot pulses within a single overshoot/undershoot event may need to be measured to determine the total pulse duration.

**Note:** Oscillations below the reference voltage can not be subtracted from the total overshoot/undershoot pulse duration.

**Note:** Multiple Overshoot/Undershoot events occurring within the same clock cycle must be considered together as one event. Using the worst case Overshoot/Undershoot Magnitude, sum together the individual Pulse Durations to determine the total Overshoot/Undershoot Pulse Duration for that total event.

### 3.2.4 Activity Factor

Activity Factor (AF) describes the frequency of overshoot (or undershoot) occurrence relative to a clock. Since the highest frequency of assertion of an AGTL or a CMOS signal is every other clock, an AF = 1 indicates that the specific overshoot (or undershoot) waveform occurs EVERY OTHER clock cycle. Thus, an AF = 0.01 indicates that the specific overshoot (or undershoot) waveform occurs one time in every 200 clock cycles.

The specifications provided in [Table 26](#) through [Table 29](#) show the Maximum Pulse Duration allowed for a given Overshoot/Undershoot Magnitude at a specific Activity Factor. Each Table entry is independent of all others, meaning that the Pulse Duration reflects the existence of overshoot/undershoot events of that magnitude ONLY. A platform with an overshoot/undershoot

that just meets the pulse duration for a specific magnitude where the  $AF < 1$ , means that there can be NO other overshoot/undershoot events, even of lesser magnitude (note that if  $AF = 1$ , then the event occurs at all times and no other events can occur).

**Note:** Activity factor for AGTL signals is referenced to system bus clock frequency.

**Note:** Activity factor for CMOS signals is referenced to PICCLK frequency.

### 3.2.5 Reading Overshoot/Undershoot Specification Tables

The overshoot/undershoot specification for the processor is not a simple single value. Instead, many factors are needed to determine what the over/undershoot specification is. In addition to the magnitude of the overshoot, the following parameters must also be known: the junction temperature the processor will be operating at, the width of the overshoot (as measured above TBD V) and the Activity Factor (AF). To determine the allowed overshoot for a particular overshoot event, the following must be done:

1. Determine the signal group that particular signal falls into. If the signal is an AGTL signal operating with a 100 MHz system bus, use [Table 27](#) (100 MHz AGTL signal group). If the signal is a CMOS signal, use [Table 28](#) (33 MHz CMOS signal group).
2. Determine the maximum case temperature (Tcase) for the range of processors that the system will support (65°C).
3. Determine the Magnitude of the overshoot (relative to VSS)
4. Determine the Activity Factor (how often does this overshoot occur?)
5. From the appropriate Specification table, read off the Maximum Pulse Duration (in ns) allowed.
6. Compare the specified Maximum Pulse Duration to the signal being measured. If the Pulse Duration measured is less than the Pulse Duration shown in the table, then the signal meets the specifications.

The above procedure is similar for undershoots after the undershoot waveform has been converted to look like an overshoot. Undershoot events must be analyzed separately from Overshoot events as they are mutually exclusive.

Below is an example showing how the maximum pulse duration is determined for a given waveform.

**Table 26. Example Platform Information**

Required Information	Maximum Platform Support	Notes
PSB Signal Group	100 MHz AGTL	
Max Tcase	72 °C	
Overshoot Magnitude	1.78 V	Measured Value
Activity Factor (AF)	0.1	Measured overshoot occurs on average every 20 clocks

Given the above parameters, and using [Table 27](#) (65°C/AF = 0.1 column) the maximum allowed pulse duration is 7.5 ns. Since the measure pulse duration is 7.5 ns, this particular overshoot event passes the overshoot specifications, although this doesn't guarantee that the combined overshoot/undershoot events meet the specifications.

### 3.2.6 Determining if a System Meets the Overshoot/Undershoot Specifications

The overshoot/undershoot specifications listed in the following tables specify the allowable overshoot/undershoot for a single overshoot/undershoot event. However most systems will have multiple overshoot and/or undershoot events that each have their own set of parameters (duration, AF and magnitude). While each overshoot on its own may meet the overshoot specification, when you add the total impact of all overshoot events, the system may fail. A guideline to ensure a system passes the overshoot and undershoot specifications is shown below. It is important to meet these guidelines; otherwise, contact your Intel field representative.

1. Insure no AGTL signal ever exceeds 1.78 V and no CMOS signal ever exceeds 2.08 V.

OR

2. If only one overshoot/undershoot event magnitude occurs, ensure it meets the over/undershoot specifications in the following tables

OR

3. If multiple overshoots and/or multiple undershoots occur, measure the worst case pulse duration for each magnitude and compare the results against the AF = 1 specifications. If all of these worst case overshoot or undershoot events meet the specifications (measured time < specifications) in the table (where AF=1), then the system passes.

The following notes apply to [Table 26](#) through [Table 29](#).

#### NOTES:

1. Overshoot/Undershoot Magnitude = 1.78 V(AGTL), 2.08 V(CMOS) is an Absolute value and should never be exceeded
2. Overshoot is measured relative to VSS.
3. Undershoot is measured relative to VTT
4. Overshoot/Undershoot Pulse Duration is measured relative to 1.32 V for AGTL and 1.80 V for CMOS.
5. Rinbacks below VTT can not be subtracted from Overshoots/Undershoots
6. Lesser Undershoot does not allocate longer or larger Overshoot
7. OEM's are encouraged to follow Intel provided layout guidelines. Consult the layout guidelines provided in the specific platform design guide.
8. All values specified by design characterization

**Table 27. 100 MHz AGTL Signal Group Overshoot/Undershoot Tolerance <sup>1, 2, 3</sup>**

Overshoot/ Undershoot Magnitude (V)	Maximum Pulse Duration at Tcase = 60 °C (ns)			Maximum Pulse Duration at Tcase = 69 °C (ns)			Maximum Pulse Duration at Tcase = 71 °C (ns)			Maximum Pulse Duration at Tcase = 72 °C (ns)		
	AF = 0.01	AF = 0.1	AF = 1	AF = 0.01	AF = 0.1	AF = 1	AF = 0.01	AF = 0.1	AF = 1	AF = 0.01	AF = 0.1	AF = 1
1.78	20	1.5	0.153	8.7	0.87	0.087	6	0.6	0.06	6	0.6	0.06
1.73	20	3.1	0.31	15	2.0	0.20	13	1.3	0.13	12	1.2	0.12
1.68	20	6.8	0.68	15	4.6	0.46	20	2.8	0.28	20	2.7	0.27
1.63	20	14	1.42	15	10	1.0	20	6.0	0.6	20	5.7	0.57
1.58	20	15	2.95	20	15	2.3	20	12.7	1.27	20	12	1.2
1.53	20	15	6.2	20	15	5.0	20	20	2.65	20	20	2.46
1.48	20	15	13.2	20	20	15	20	20	5.45	20	20	5.10

- Notes:**
1. Measurements taken at the processor socket pins on the solder-side of the motherboard.
  2. Overshoot/Undershoot Magnitude = 1.78 V is an absolute value and should never be exceeded.
  3. BCLK Period = 10.0 ns.

Figure 20. Maximum Acceptable AGTL Overshoot/Undershoot Waveform

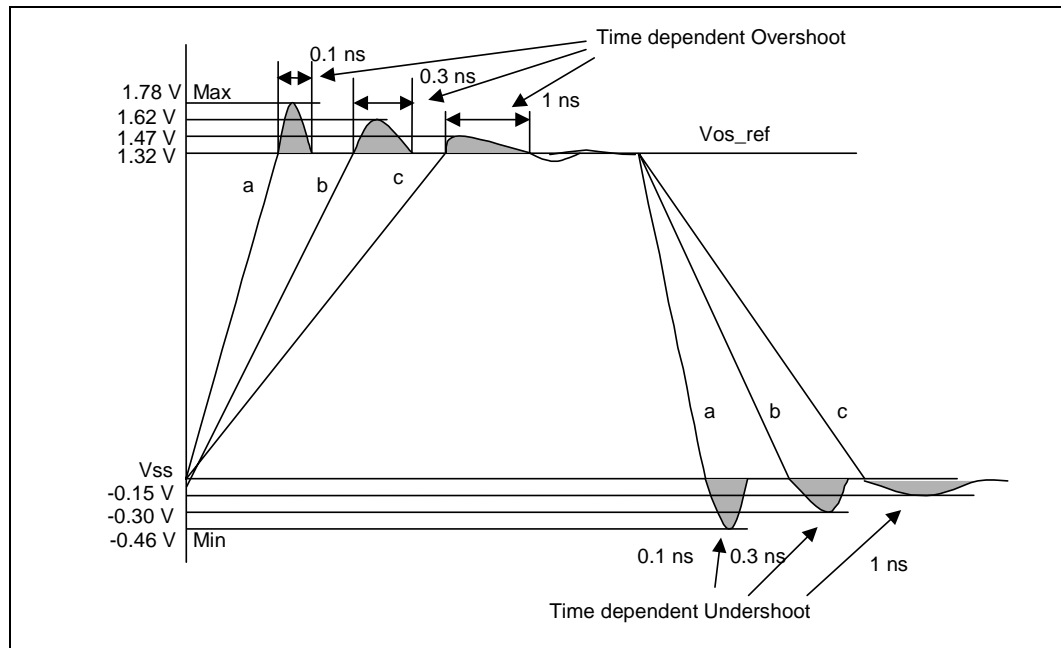

### 3.3 Non-AGTL Signal Quality Specifications and Measurement Guidelines

There are three signal quality parameters defined for non-AGTL signals: overshoot/undershoot, ringback, and settling limit. All three signal quality parameters are shown in Figure 21 for the non-AGTL signal group.

Figure 21. Non-AGTL Overshoot/Undershoot, Settling Limit, and Ringback <sup>1</sup>

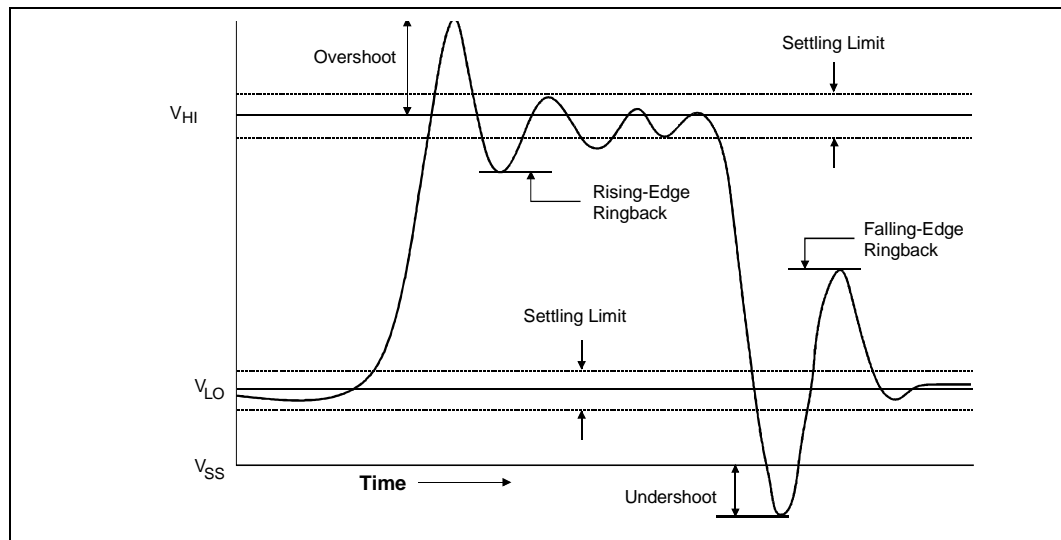

**NOTE:**

1.  $V_{HI} = 1.80\text{ V}$  for all non-AGTL signals except for BCLK, PICCLK, and PWRGOOD.  $V_{HI} = 2.0\text{ V}$  for PICCLK, and  $V_{HI} = 1.8\text{ V}$  for PWRGOOD. BCLK and PICCLK signal quality is detailed in Section 3.1.

### 3.3.1 Overshoot/Undershoot Guidelines

Overshoot (or undershoot) is the absolute value of the maximum voltage above the nominal high voltage or below VSS. The overshoot guideline limits transitions beyond VCC or VSS due to the fast signal edge rates (see [Figure 21](#) for non-AGTL signals). The processor can be damaged by repeated overshoot events on 1.25 V or 1.8 V tolerant buffers if the charge is large enough (i.e., if the overshoot is great enough). Permanent damage to the processor is the likely result of excessive overshoot/undershoot. Violating the overshoot/undershoot guideline will also make satisfying the ringback specification difficult. *The overshoot/undershoot guideline is 0.3 V and assumes the absence of diodes on the input.* These guidelines should be verified in simulations *without the on-chip ESD protection diodes present* because the diodes will begin clamping the 1.25 V and 2.5 V tolerant signals beginning at approximately 0.7 V above the appropriate supply and 0.7 V below VSS. If signals are not reaching the clamping voltage, this will not be an issue. A system should not rely on the diodes for overshoot/undershoot protection as this will negatively affect the life of the components and make meeting the ringback specification very difficult.

**Table 28. 33 MHz CMOS Signal Group Overshoot/Undershoot Tolerance**

Overshoot/ Undershoot Magnitude (V)	Maximum Pulse Duration at Tcase = 69 °C (ns)			Maximum Pulse Duration at Tcase = 71 °C (ns)			Maximum Pulse Duration at Tcase = 72 °C (ns)		
	AF = 0.01	AF = 0.1	AF = 1	AF = 0.01	AF = 0.1	AF = 1	AF = 0.01	AF = 0.1	AF = 1
2.38	35	3.5	0.35	19	1.9	0.19	17	1.7	0.17
2.33	60	8.0	0.8	40	4.0	0.40	36	3.6	0.36
2.28	60	18	1.8	60	8.0	0.80	60	7.7	0.77
2.23	60	41	4.1	60	18	1.80	60	16	1.60
2.18	60	60	9.0	60	37.5	3.75	60	34	3.42
2.13	60	60	21	60	60	8.00	60	60	7.12
2.08	60	60	60	60	60	16.00	60	60	14.5

**Note:** The undershoot guideline limits transitions exactly as described for the ATGL signals. See [Figure 20](#).

### 3.3.2 Ringback Specification

Ringback refers to the amount of reflection seen after a signal has switched. The ringback specification is the voltage that the signal rings back to after achieving its maximum absolute value. See [Figure 21](#) for an illustration of ringback. Excessive ringback can cause false signal detection or extend the propagation delay. The ringback specification applies to the input pin of each receiving agent. Violations of the signal ringback specification are not allowed under any circumstances for non-AGTL signals.

Ringback can be simulated with or without the input protection diodes that can be added to the input buffer model. However, signals that reach the clamping voltage should be evaluated further. See [Table 29](#) for the signal ringback specifications for non-AGTL signals for simulations at the processor pins.



**Table 29. Signal Ringback Specifications for Non-AGTL Signal Simulation at the Processor Pins**

Input Signal Group	Transition	Maximum Ringback (with Input Diodes Present)	Unit	Figure
Non-AGTL Signals <sup>2</sup>	0 → 1	V <sub>cmos_ref</sub> + 0.200	V	21
Non-AGTL Signals <sup>2</sup>	1 → 0	V <sub>cmos_ref</sub> - 0.300	V	21
PWRGOOD	0 → 1	1.44	V	21

**NOTES:**

1. Unless otherwise noted, all specifications in this table apply to the processor up to 1.40 GHz frequency.
2. Non-AGTL signals except PWRGOOD.

### 3.3.3 Settling Limit Guideline

Settling limit defines the maximum amount of ringing at the receiving pin that a signal must reach before its next transition. The amount allowed is 10% of the total signal swing ( $V_{HI} - V_{LO}$ ) above and below its final value. A signal should be within the settling limits of its final value, when either in its high state or low state, before it transitions again.

Signals that are not within their settling limit before transitioning are at risk of unwanted oscillations which could jeopardize signal integrity. Simulations to verify settling limit may be done either with or without the input protection diodes present. Violation of the settling limit guideline is acceptable if simulations of 5 to 10 successive transitions do not show the amplitude of the ringing increasing in the subsequent transitions.

## 3.4 VTT\_PWRGD Signal Quality Specification

The VTT\_PWRGD signal is an input to the processor used to determine that the VTT power is stable and the VID and BSEL signals should be driven to their final state by the processor. To ensure the processor correctly reads this signal, it must meet the following requirement while the signal is in its transition region of 300 mV to 900 mV. Also, VTT\_PWRGD should only enter the transition region once, after VTT is at nominal values, for the assertion of the signal.

$$\text{Amount of noise (glitch)} < 100 \text{ mV}$$

In addition, the VTT\_PWRGD signal should have a reasonable transition time through the transition region. A sharp edge on the signal transition will minimize the chance of noise causing a glitch on this signal. Intel recommends the following transition time for the VTT\_PWRGD signal.

$$\text{Transition time (300 mV to 900 mV)} \leq 100 \text{ us}$$

### 3.4.1 Transition region

The transition region covered by this requirement is 300 mV to 900 mV. Once the VTT\_PWRGD signal is in that voltage range, the processor is more sensitive to noise which may be present on the signal. The transition region when the signal first crosses the 300 mV voltage level and continues until the last time it is below 900 mV.

### 3.4.2 Transition time

The transition time is defined as the time the signal takes to move through the transition region. A 100 microsecond transition time will ensure that the processor receives a good transition edge.

### 3.4.3 Noise

The signal quality of the VTT\_PWRGD signal is critical to the correct operation of the processor. Every effort should be made to ensure this signal is monotonic in the transition region. If noise or glitches are present on this signal, it must be kept to less than 100 mV of a voltage drop from the highest voltage level received to that point. This glitch must remain less than 100 mV until the excursion ends by the voltage returning to the highest voltage previously received. See Figure 22 for an example graph of this situation and requirements.

Figure 22. Noise Estimation

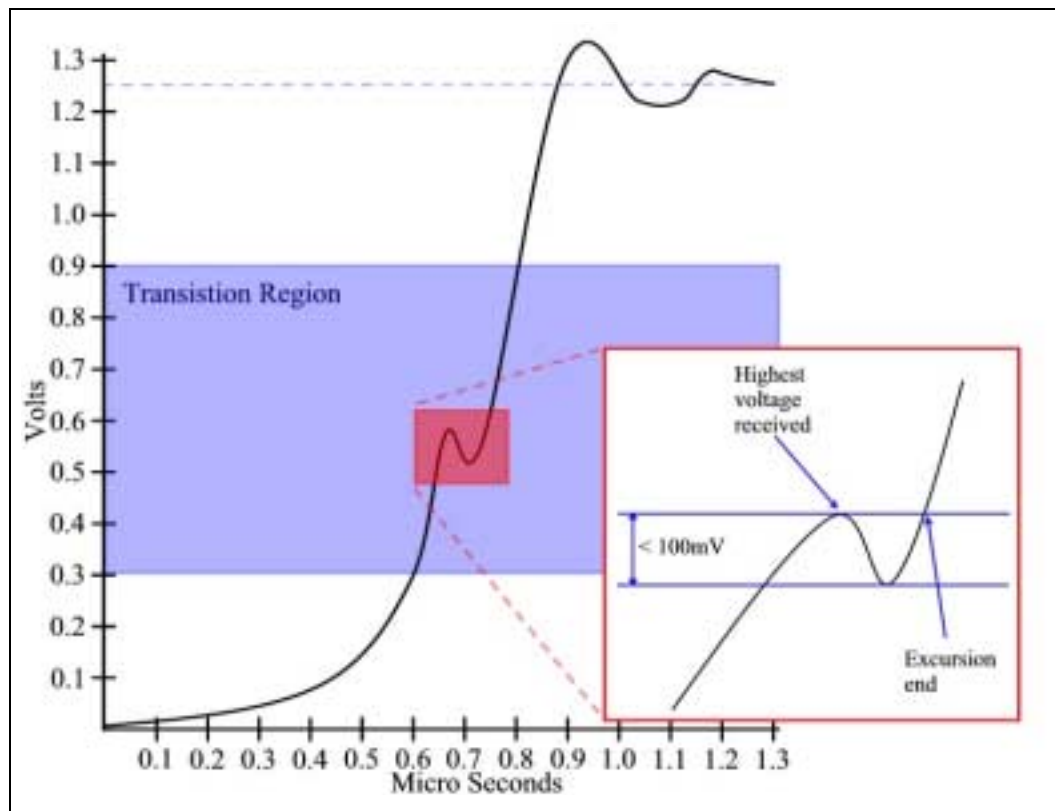

## 4.0 Thermal Specifications and Design Considerations

This chapter provides needed data for designing a thermal solution. However, for the correct thermal measuring processes, refer to *Intel® Pentium® III Processor in the FC-PGA2, 370-pin Package Thermal Design Guidelines* (Order Number 249660). The processor uses flip chip pin grid array packaging technology with a Integrated Heat Spreader and has a case temperature ( $T_{case}$ ) specified.

### 4.1 Thermal Specifications

Table 30 provides the thermal design power dissipation and maximum temperatures for the processor. Systems should design for the highest possible processor power, even if a processor with a lower thermal dissipation is planned. A thermal solution should be designed to ensure the case temperature never exceeds these specifications.

**Table 30. Processor Thermal Design Power <sup>1</sup>**

Processor	Processor Core Frequency	L2 Cache Size (Kbytes)	Processor Power <sup>2</sup> (W)	Maximum $T_{CASE}$ (°C)
1.40 <sup>4</sup>	1.40	256	34.8	72
1.30 <sup>4</sup>	1.30 GHz	256	33.4	71
1.20	1.20 GHz	256	32.1	70
1.20 <sup>5</sup>	1.20 GHz	256	29.9	69
1.10A	1.10A GHz	256	28.9	69
1A	1A GHz	256	27.8	69
900	900 MHz	256	26.3	69

1. These values are specified at nominal  $V_{CC_{CORE}}$  for the processor pins.
2. Processor power includes the power dissipated by the processor core, the L2 cache, and the AGTL bus termination. The maximum power for each of these components does not occur simultaneously.
3. Processor core power includes only the power dissipated by the core die.
4. For frequencies beyond 1.4 GHz, refer to the latest flexible motherboard 1 extended (FMB1-E) guidelines available via your Intel Representative.
5. 1.20 GHz at  $V_{CC_{CORE}} = 1.475$  volts and S-Spec number SL5XS.

#### 4.1.1 THERMTRIP# Requirement

In the event the processor drives the THERMTRIP# signal active during valid operation, both the VCC and VTT supplies to the processor must be turned off to prevent thermal runaway of the processor. Valid operation refers to the operating conditions where the THERMTRIP# signal is guaranteed valid. The time required from THERMTRIP# asserted to VCC rail at 1/2 nominal is 5 s and THERMTRIP# asserted to VTT rail at 1/2 nominal is 5 s.

**Table 31. THERMTRIP# Time Requirement**

Power Rail	Power Target	Time Required for Power Drop
VCC	1/2 Nominal VCC	5 seconds
VTT	1/2 Nominal VTT	5 seconds

**NOTE:** Once VCC and VTT supplies are turned off the THERMTRIP# signal will be deactivated. System logic should ensure no “unsafe” power cycling occurs due to this deassertion.

## 4.1.2 Thermal Diode

The processor incorporates an on-die diode that may be used to monitor the die temperature (junction temperature). A thermal sensor located on the motherboard, or a stand-alone measurement kit, may monitor the die temperature of the processor for thermal management or instrumentation purposes. Table 32 and Table 33 provide the diode parameter and interface specifications.

The processor uses an Integrated Heat Spreader (IHS) and has a case temperature requirement. Please see the *Intel® Pentium® III Processor in the FC-PGA2, 370-pin Package Thermal Design Guidelines* document for details on measuring the case temperature. The thermal diode should be used for system thermal management and not determining spec compliance.

**Table 32. Thermal Diode Parameters**

Symbol	Parameter	Min	Typ	Max	Unit	Notes <sup>1</sup>
$I_{fw}$	Forward Bias Current	5	N/A	150	μA	1
n	Diode Ideality Factor	1.001452	1.007152	1.012852		2, 4, 5
$I_{fw}$	Forward Bias Current	5	N/A	300	μA	1
n	Diode Ideality Factor	1.000807	1.009528	1.018249		3, 4, 5

**NOTES:**

- Intel does not support or recommend operation of the thermal diode under reverse bias.
- Characterized at 75° C with a forward bias current of 5 – 150 μA.
- Characterized at 75° C with a forward bias current of 5 – 300 μA.
- The ideality factor, n, represents the deviation from ideal diode behavior as exemplified by the diode equation:  

$$I_{fw} = I_s (e^{(V_d \cdot q) / (n \cdot k \cdot T)} - 1)$$
 where  $I_s$  = saturation current,  $q$  = electronic charge,  $V_d$  = voltage across the diode,  $k$  = Boltzmann Constant, and  $T$  = absolute temperature (Kelvin).
- Not 100% tested. Specified by design characterization.

**Table 33. Thermal Diode Interface**

Pin Name	PGA370 Socket pin #	Pin Description
THERMDP	AL31	diode anode (p_junction)
THERMDN	AL29	diode cathode (n_junction)

## 4.2 Thermal Metrology

The thermal metrology for the processor in the FC-PGA2 package should be followed to evaluate the thermal performance of proposed cooling solutions. The thermal metrology is contained in the *Intel® Pentium® III Processor in the FC-PGA2, 370-pin Package Thermal Design Guidelines*. Please contact your local Intel field office to obtain this document.

## 5.0 Mechanical Specifications

The processor uses a FC-PGA2 package technology. Mechanical specifications for the processor are given in this section. See [Section 1.1.1](#) for a complete terminology listing.

The processor utilizes a PGA370 socket for installation into the motherboard. Details on the socket are available in the *370-Pin Socket (PGA370) Design Guidelines*.

**Note:** For [Figure 23](#), the following apply:

1. Unless otherwise specified, the following drawings are dimensioned in inches.
2. All dimensions provided with tolerances are guaranteed to be met for all normal production product.
3. Figures and drawings labeled as “Reference Dimensions” are provided for informational purposes only. Reference dimensions are extracted from the mechanical design database and are nominal dimensions with no tolerance information applied. Reference dimensions are NOT checked as part of the processor manufacturing. Unless noted as such, dimensions in parentheses without tolerances are reference dimensions.
4. Drawings are not to scale.

### 5.1 FC-PGA2 Mechanical Specifications

The following figure with package dimensions is provided to aid in the design of heatsink and clip solutions as well as demonstrate where pin-side capacitors will be located on the processor.

[Table 34](#) includes the measurements for these dimensions in both inches and millimeters.

**Figure 23. Package Dimensions**

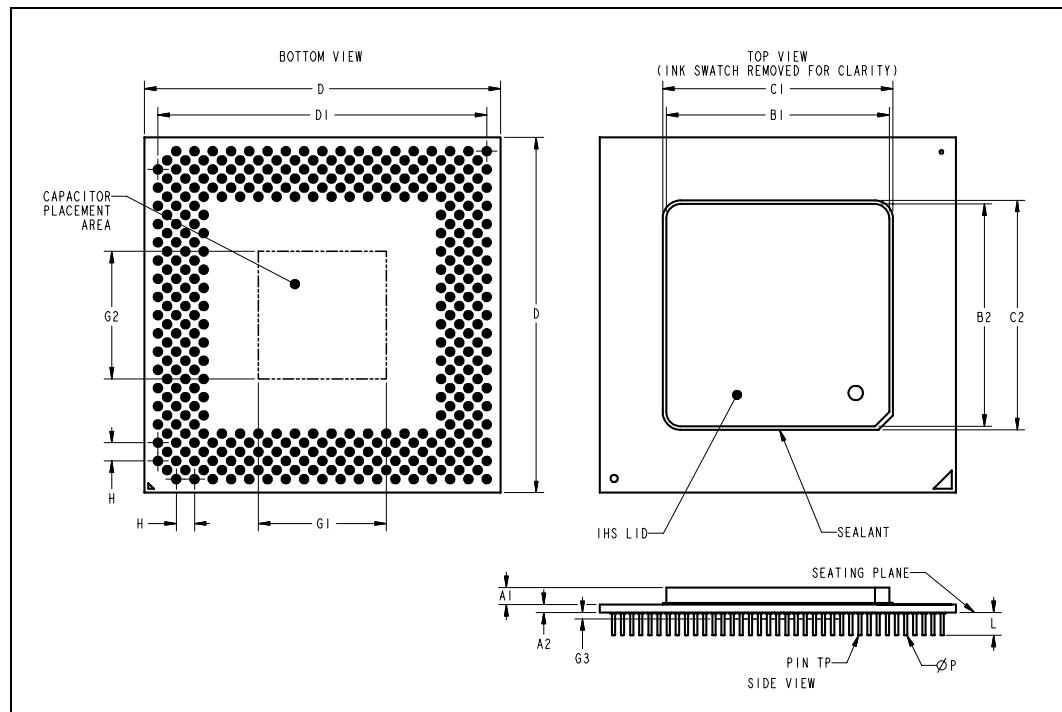

Table 34. The Processor Package Dimensions

Symbol	Millimeters			Inches		
	Minimum	Maximum	Notes	Minimum	Maximum	Notes
A1	2.266	2.690		0.089	0.106	
A2	0.980	1.180		0.038	0.047	
B1	30.800	31.200		1.212	1.229	
B2	30.800	31.200		1.212	1.229	
C1	33.000 max			1.299 max		
C2	33.000 max			1.299 max		
D	49.428	49.632		1.946	1.954	
D1	45.466	45.974		1.790	1.810	
G1	0.000	17.780		0.000	0.700	
G2	0.000	17.780		0.000	0.700	
G3	0.000	0.889		0.000	0.035	
H	2.540		Nominal	0.100		Nominal
L	3.048	3.302		0.120	0.130	
$\Phi$ P	0.431	0.483		0.017	0.019	
Pin TP	0.508 Diametric True Position (Pin-to-Pin)			0.020 Diametric True Position (Pin-to-Pin)		

**NOTE:** Capacitors will be placed on the pin-side of the FC-PGA2 package in the area defined by G1, G2, and G3. This area is a keepout zone for motherboard designers.

For Table 35, the following apply:

1. It is not recommended to use any portion of the processor substrate as a mechanical reference or load bearing surface for thermal solutions.
2. Parameters assume uniformly applied loads

Table 35. Processor Case Loading Parameters

Parameter	Dynamic (max) <sup>1</sup>	Static (max) <sup>2,3</sup>	Unit
IHS Surface	200	100	lbf
IHS Edge	125	N/A	lbf
IHS Corner	75	N/A	ibf

**NOTES:**

1. This specification applies to a uniform and a non-uniform load.
2. This is the maximum static force that can be applied by the heatsink and clip to maintain the heatsink and processor interface.
3. Please see socket manufacturer's force loading specification also to ensure compliance. Maximum static loading listed here does not account for the maximum reaction forces on the socket tabs or pins.

## 5.2 Recommended Mechanical Keep-Out Zones

Figure 24. Volumetric Keep-Out

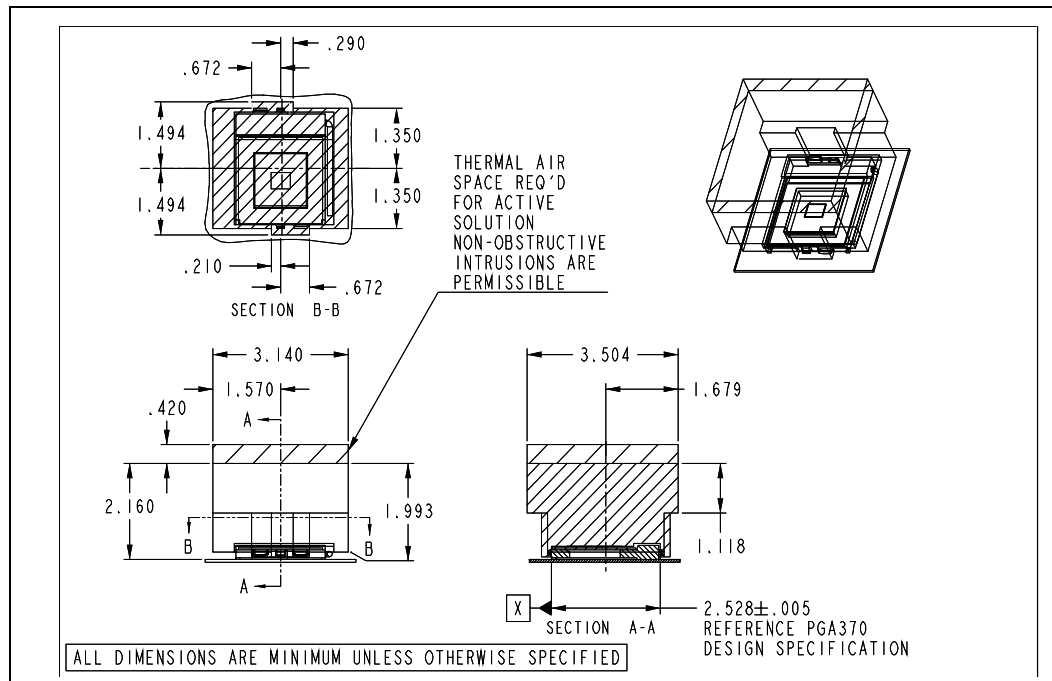
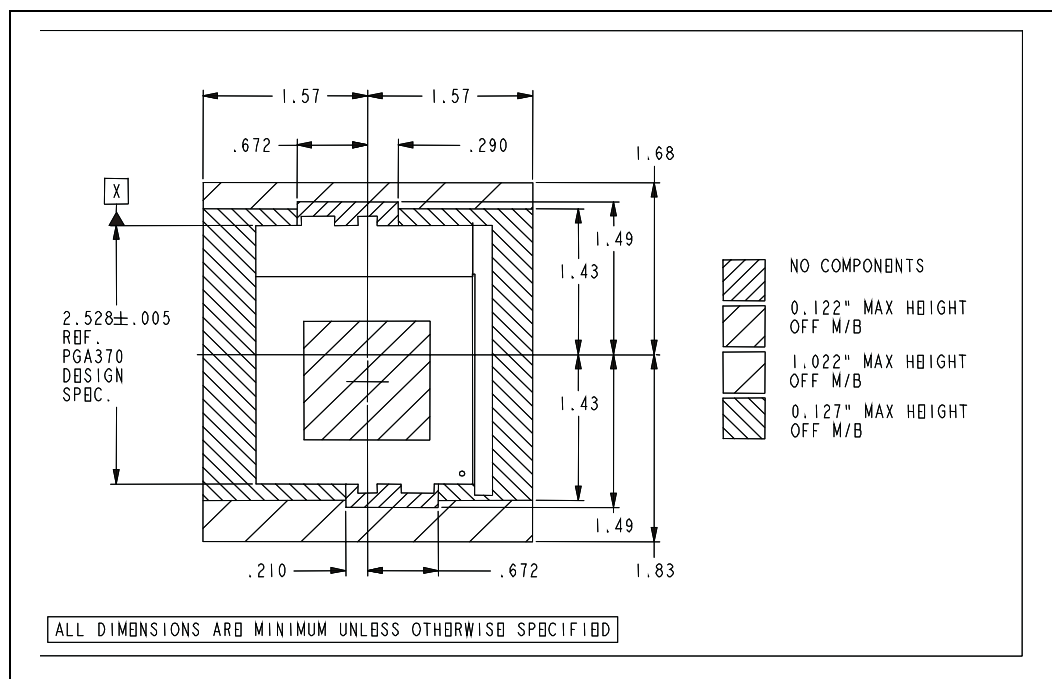

Figure 25. Component Keep-Out



### 5.3 Processor Markings

Figure 26 shows the processor top-side markings and it is provided to aid in the identification of the Celeron processor. Table 34 lists the measurements for the package dimensions.

Figure 26. Top Side Processor Markings

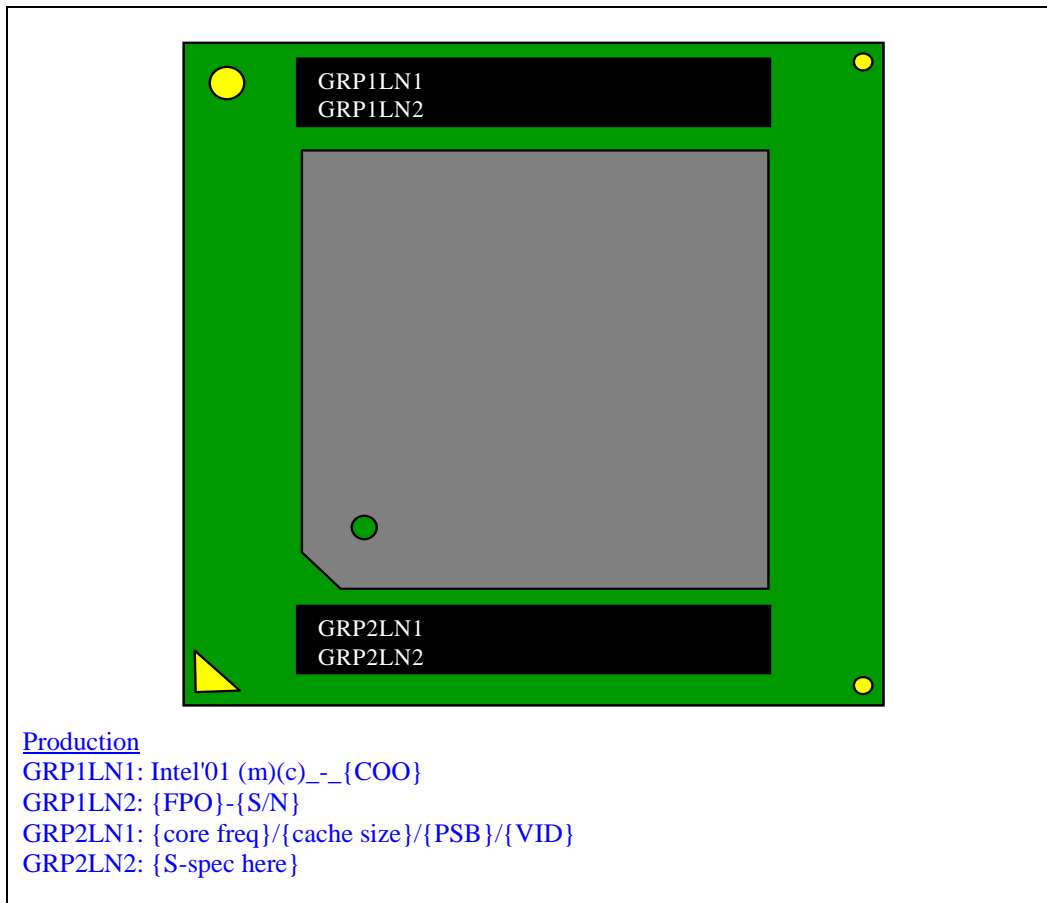



### 5.4 Processor Signal Listing

Table 36 and Table 37 provide the processor pin definitions. The signal locations on the PGA370 socket are to be used for signal routing, simulation, and component placement on the baseboard. Figure 27 provides a pin-side view of the processor pinout.

Figure 27. Processor Pinout

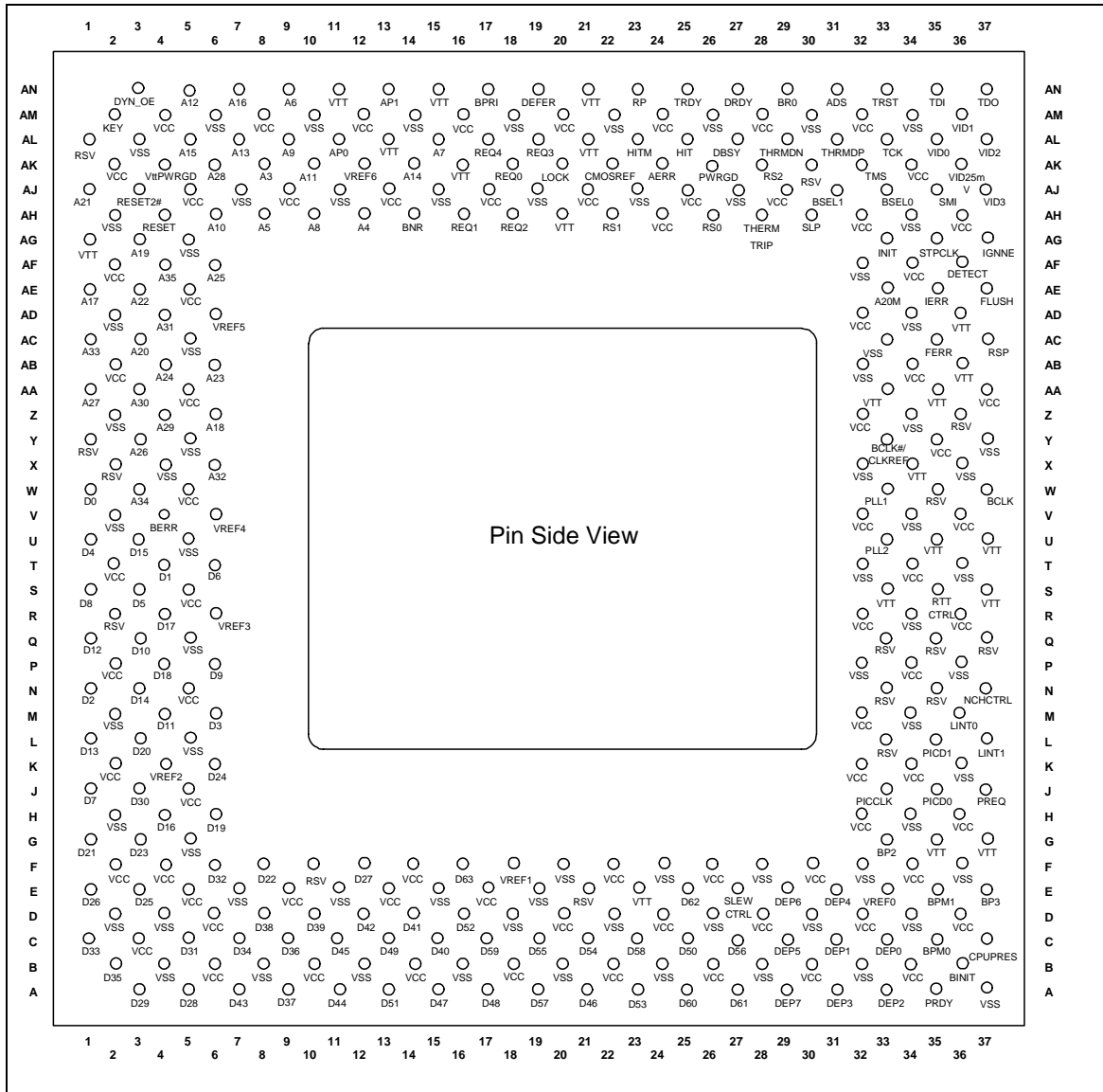

Table 36. Signal Listing in Order by Signal Name

Pin No.	Pin Name	Signal Group
AH6	A10#	AGTL I/O
AK10	A11#	AGTL I/O
AN5	A12#	AGTL I/O
AL7	A13#	AGTL I/O
AK14	A14#	AGTL I/O
AL5	A15#	AGTL I/O
AN7	A16#	AGTL I/O
AE1	A17#	AGTL I/O
Z6	A18#	AGTL I/O
AG3	A19#	AGTL I/O
AC3	A20#	AGTL I/O
AE33	A20M#	CMOS Input
AJ1	A21#	AGTL I/O
AE3	A22#	AGTL I/O
AB6	A23#	AGTL I/O
AB4	A24#	AGTL I/O
AF6	A25#	AGTL I/O
Y3	A26#	AGTL I/O
AA1	A27#	AGTL I/O
AK6	A28#	AGTL I/O
Z4	A29#	AGTL I/O
AK8	A3#	AGTL I/O
AA3	A30#	AGTL I/O
AD4	A31#	AGTL I/O
X6	A32#	AGTL I/O
AC1	A33#	AGTL I/O
W3	A34#	AGTL I/O
AF4	A35#	AGTL I/O
AH12	A4#	AGTL I/O
AH8	A5#	AGTL I/O
AN9	A6#	AGTL I/O
AL15	A7#	AGTL I/O
AH10	A8#	AGTL I/O
AL9	A9#	AGTL I/O
AN31	ADS#	AGTL I/O
AK24	AERR#	AGTL I/O
AL11	AP0#	AGTL I/O
AN13	AP1#	AGTL I/O
W37	BCLK	System Bus Clock
Y33	BCLK#/CLKREF	System Bus Clock

Table 36. Signal Listing in Order by Signal Name (Continued)

Pin No.	Pin Name	Signal Group
V4	BERR#	AGTL I/O
B36	BINIT#	AGTL I/O
AH14	BNR#	AGTL I/O
G33	BP2#	AGTL I/O
E37	BP3#	AGTL I/O
C35	BPM0#	AGTL I/O
E35	BPM1#	AGTL I/O
AN17	BPRI#	AGTL Input
AN29	BR0#	AGTL I/O
X2	Reserved	AGTL I/O
AJ33	BSEL0	3.3V Output
AJ31	BSEL1	3.3V Output
C37	CPUPRES#	Power/Other
W1	D0#	AGTL I/O
T4	D1#	AGTL I/O
Q3	D10#	AGTL I/O
M4	D11#	AGTL I/O
Q1	D12#	AGTL I/O
L1	D13#	AGTL I/O
N3	D14#	AGTL I/O
U3	D15#	AGTL I/O
H4	D16#	AGTL I/O
R4	D17#	AGTL I/O
P4	D18#	AGTL I/O
H6	D19#	AGTL I/O
N1	D2#	AGTL I/O
L3	D20#	AGTL I/O
G1	D21#	AGTL I/O
F8	D22#	AGTL I/O
G3	D23#	AGTL I/O
K6	D24#	AGTL I/O
E3	D25#	AGTL I/O
E1	D26#	AGTL I/O
F12	D27#	AGTL I/O
A5	D28#	AGTL I/O
A3	D29#	AGTL I/O
M6	D3#	AGTL I/O
J3	D30#	AGTL I/O
C5	D31#	AGTL I/O
F6	D32#	AGTL I/O

**Table 36. Signal Listing in Order by Signal Name (Continued)**

Pin No.	Pin Name	Signal Group
C1	D33#	AGTL I/O
C7	D34#	AGTL I/O
B2	D35#	AGTL I/O
C9	D36#	AGTL I/O
A9	D37#	AGTL I/O
D8	D38#	AGTL I/O
D10	D39#	AGTL I/O
U1	D4#	AGTL I/O
C15	D40#	AGTL I/O
D14	D41#	AGTL I/O
D12	D42#	AGTL I/O
A7	D43#	AGTL I/O
A11	D44#	AGTL I/O
C11	D45#	AGTL I/O
A21	D46#	AGTL I/O
A15	D47#	AGTL I/O
A17	D48#	AGTL I/O
C13	D49#	AGTL I/O
S3	D5#	AGTL I/O
C25	D50#	AGTL I/O
A13	D51#	AGTL I/O
D16	D52#	AGTL I/O
A23	D53#	AGTL I/O
C21	D54#	AGTL I/O
C19	D55#	AGTL I/O
C27	D56#	AGTL I/O
A19	D57#	AGTL I/O
C23	D58#	AGTL I/O
C17	D59#	AGTL I/O
T6	D6#	AGTL I/O
A25	D60#	AGTL I/O
A27	D61#	AGTL I/O
E25	D62#	AGTL I/O
F16	D63#	AGTL I/O
J1	D7#	AGTL I/O
S1	D8#	AGTL I/O
P6	D9#	AGTL I/O
AL27	DBSY#	AGTL I/O
AN19	DEFER#	AGTL Input
C33	DEP0#	AGTL I/O

**Table 36. Signal Listing in Order by Signal Name (Continued)**

Pin No.	Pin Name	Signal Group
C31	DEP1#	AGTL I/O
A33	DEP2#	AGTL I/O
A31	DEP3#	AGTL I/O
E31	DEP4#	AGTL I/O
C29	DEP5#	AGTL I/O
E29	DEP6#	AGTL I/O
A29	DEP7#	AGTL I/O
AF36	DETECT	Power/Other
AN27	DRDY#	AGTL I/O
AN3	DYN_OE	Power/Other
AC35	FERR#	CMOS Output
AE37	FLUSH#	CMOS Input
AL25	HIT#	AGTL I/O
AL23	HITM#	AGTL I/O
AE35	IERR#	CMOS Output
AG37	IGNNE#	CMOS Input
AG33	INIT#	CMOS Input
AM2	KEY	Power/Other
M36	LINT0/INTR	CMOS Input
L37	LINT1/NMI	CMOS Input
AK20	LOCK#	AGTL I/O
N37	NCHCTRL	Power/Other
J33	PICCLK	APIC Clock Input
J35	PICD0	APIC I/O
L35	PICD1	APIC I/O
W33	PLL1	Power/Other
U33	PLL2	Power/Other
A35	PRDY#	AGTL Output
J37	PREQ#	CMOS Input
AK26	PWRGOOD	CMOS Input
AK18	REQ0#	AGTL I/O
AH16	REQ1#	AGTL I/O
AH18	REQ2#	AGTL I/O
AL19	REQ3#	AGTL I/O
AL17	REQ4#	AGTL I/O
AK30	Reserved	Reserved for future use
AL1	Reserved	Reserved for future use
F10	Reserved	Reserved for future use
E21	Reserved	Reserved for future use
L33	Reserved	Reserved for future use

Table 36. Signal Listing in Order by Signal Name (Continued)

Pin No.	Pin Name	Signal Group
N33	Reserved	Reserved for future use
N35	Reserved	Reserved for future use
Q33	Reserved	Reserved for future use
Q35	Reserved	Reserved for future use
Q37	Reserved	Reserved for future use
R2	Reserved	Reserved for future use
W35	Reserved	Reserved for future use
Y1	Reserved	Reserved for future use
Z36	Reserved	Reserved for future use
AH4	RESET#	AGTL Input
AJ3	RESET2#	AGTL Input
AN23	RP#	AGTL I/O
AH26	RS0#	AGTL + Input
AH22	RS1#	AGTL Input
AK28	RS2#	AGTL Input
AC37	RSP#	AGTL Input
S35	RTTCTRL	Power/Other
E27	SLEWCTRL	Power/Other
AH30	SLP#	CMOS Input
AJ35	SMI#	CMOS Input
AG35	STPCLK#	CMOS Input
AL33	TCK	TAP Input
AN35	TDI	TAP Input
AN37	TDO	TAP Output
AL29	THERMDN	Power/Other
AL31	THERMDP	Power/Other
AH28	THERMTRIP#	CMOS Output
AK32	TMS	TAP Input
AN25	TRDY#	AGTL Input
AN33	TRST#	TAP Input
AA37	VCC <sub>CORE</sub>	Power/Other
AA5	VCC <sub>CORE</sub>	Power/Other
AB2	VCC <sub>CORE</sub>	Power/Other
AB34	VCC <sub>CORE</sub>	Power/Other
AD32	VCC <sub>CORE</sub>	Power/Other
AE5	VCC <sub>CORE</sub>	Power/Other
AF2	VCC <sub>CORE</sub>	Power/Other
AF34	VCC <sub>CORE</sub>	Power/Other
AH24	VCC <sub>CORE</sub>	Power/Other
AH32	VCC <sub>CORE</sub>	Power/Other

Table 36. Signal Listing in Order by Signal Name (Continued)

Pin No.	Pin Name	Signal Group
AH36	VCC <sub>CORE</sub>	Power/Other
AJ13	VCC <sub>CORE</sub>	Power/Other
AJ17	VCC <sub>CORE</sub>	Power/Other
AJ21	VCC <sub>CORE</sub>	Power/Other
AJ25	VCC <sub>CORE</sub>	Power/Other
AJ29	VCC <sub>CORE</sub>	Power/Other
AJ5	VCC <sub>CORE</sub>	Power/Other
AJ9	VCC <sub>CORE</sub>	Power/Other
AK2	VCC <sub>CORE</sub>	Power/Other
AK34	VCC <sub>CORE</sub>	Power/Other
AM12	VCC <sub>CORE</sub>	Power/Other
AM16	VCC <sub>CORE</sub>	Power/Other
AM20	VCC <sub>CORE</sub>	Power/Other
AM24	VCC <sub>CORE</sub>	Power/Other
AM28	VCC <sub>CORE</sub>	Power/Other
AM32	VCC <sub>CORE</sub>	Power/Other
AM4	VCC <sub>CORE</sub>	Power/Other
AM8	VCC <sub>CORE</sub>	Power/Other
B10	VCC <sub>CORE</sub>	Power/Other
B14	VCC <sub>CORE</sub>	Power/Other
B18	VCC <sub>CORE</sub>	Power/Other
B22	VCC <sub>CORE</sub>	Power/Other
B26	VCC <sub>CORE</sub>	Power/Other
B30	VCC <sub>CORE</sub>	Power/Other
B34	VCC <sub>CORE</sub>	Power/Other
B6	VCC <sub>CORE</sub>	Power/Other
C3	VCC <sub>CORE</sub>	Power/Other
D20	VCC <sub>CORE</sub>	Power/Other
D24	VCC <sub>CORE</sub>	Power/Other
D28	VCC <sub>CORE</sub>	Power/Other
D32	VCC <sub>CORE</sub>	Power/Other
D36	VCC <sub>CORE</sub>	Power/Other
D6	VCC <sub>CORE</sub>	Power/Other
E13	VCC <sub>CORE</sub>	Power/Other
E17	VCC <sub>CORE</sub>	Power/Other
E5	VCC <sub>CORE</sub>	Power/Other
E9	VCC <sub>CORE</sub>	Power/Other
F14	VCC <sub>CORE</sub>	Power/Other
F2	VCC <sub>CORE</sub>	Power/Other
F22	VCC <sub>CORE</sub>	Power/Other

**Table 36. Signal Listing in Order by Signal Name (Continued)**

Pin No.	Pin Name	Signal Group
F26	VCC <sub>CORE</sub>	Power/Other
F30	VCC <sub>CORE</sub>	Power/Other
F34	VCC <sub>CORE</sub>	Power/Other
F4	VCC <sub>CORE</sub>	Power/Other
H32	VCC <sub>CORE</sub>	Power/Other
H36	VCC <sub>CORE</sub>	Power/Other
J5	VCC <sub>CORE</sub>	Power/Other
K2	VCC <sub>CORE</sub>	Power/Other
K32	VCC <sub>CORE</sub>	Power/Other
K34	VCC <sub>CORE</sub>	Power/Other
M32	VCC <sub>CORE</sub>	Power/Other
N5	VCC <sub>CORE</sub>	Power/Other
P2	VCC <sub>CORE</sub>	Power/Other
P34	VCC <sub>CORE</sub>	Power/Other
R32	VCC <sub>CORE</sub>	Power/Other
R36	VCC <sub>CORE</sub>	Power/Other
S5	VCC <sub>CORE</sub>	Power/Other
T2	VCC <sub>CORE</sub>	Power/Other
T34	VCC <sub>CORE</sub>	Power/Other
V32	VCC <sub>CORE</sub>	Power/Other
V36	VCC <sub>CORE</sub>	Power/Other
W5	VCC <sub>CORE</sub>	Power/Other
Y35	VCC <sub>CORE</sub>	Power/Other
Z32	VCC <sub>CORE</sub>	Power/Other
AK22	V <sub>CMOS_REF</sub>	Power/Other
AK36	VID 25mV	3.3V Output
AL35	VID0	3.3V Output
AM36	VID1	3.3V Output
AL37	VID2	3.3V Output
AJ37	VID3	3.3V Output
E33	V <sub>REF0</sub>	Power/Other
F18	V <sub>REF1</sub>	Power/Other
K4	V <sub>REF2</sub>	Power/Other
R6	V <sub>REF3</sub>	Power/Other
V6	V <sub>REF4</sub>	Power/Other
AD6	V <sub>REF5</sub>	Power/Other
AK12	V <sub>REF6</sub>	Power/Other
A37	Vss	Power/Other
AB32	Vss	Power/Other
AC33	Vss	Power/Other

**Table 36. Signal Listing in Order by Signal Name (Continued)**

Pin No.	Pin Name	Signal Group
AC5	Vss	Power/Other
AD2	Vss	Power/Other
AD34	Vss	Power/Other
AF32	Vss	Power/Other
AG5	Vss	Power/Other
AH2	Vss	Power/Other
AH34	Vss	Power/Other
AJ11	Vss	Power/Other
AJ15	Vss	Power/Other
AJ19	Vss	Power/Other
AJ23	Vss	Power/Other
AJ27	Vss	Power/Other
AJ7	Vss	Power/Other
AL3	Vss	Power/Other
AM10	Vss	Power/Other
AM14	Vss	Power/Other
AM18	Vss	Power/Other
AM22	Vss	Power/Other
AM26	Vss	Power/Other
AM30	Vss	Power/Other
AM34	Vss	Power/Other
AM6	Vss	Power/Other
B12	Vss	Power/Other
B16	Vss	Power/Other
B20	Vss	Power/Other
B24	Vss	Power/Other
B28	Vss	Power/Other
B32	Vss	Power/Other
B4	Vss	Power/Other
B8	Vss	Power/Other
D18	Vss	Power/Other
D2	Vss	Power/Other
D22	Vss	Power/Other
D26	Vss	Power/Other
D30	Vss	Power/Other
D34	Vss	Power/Other
D4	Vss	Power/Other
E11	Vss	Power/Other
E15	Vss	Power/Other
E19	Vss	Power/Other

**Table 36. Signal Listing in Order by Signal Name (Continued)**

Pin No.	Pin Name	Signal Group
E7	Vss	Power/Other
F20	Vss	Power/Other
F24	Vss	Power/Other
F28	Vss	Power/Other
F32	Vss	Power/Other
F36	Vss	Power/Other
G5	Vss	Power/Other
H2	Vss	Power/Other
H34	Vss	Power/Other
K36	Vss	Power/Other
L5	Vss	Power/Other
M2	Vss	Power/Other
M34	Vss	Power/Other
P32	Vss	Power/Other
P36	Vss	Power/Other
Q5	Vss	Power/Other
R34	Vss	Power/Other
T32	Vss	Power/Other
T36	Vss	Power/Other
U5	Vss	Power/Other
V2	Vss	Power/Other
V34	Vss	Power/Other
X32	Vss	Power/Other
X36	Vss	Power/Other
X4	Vss	Power/Other

**Table 36. Signal Listing in Order by Signal Name (Continued)**

Pin No.	Pin Name	Signal Group
Y37	Vss	Power/Other
Y5	Vss	Power/Other
Z2	Vss	Power/Other
Z34	Vss	Power/Other
AB36	V <sub>TT</sub>	Power/Other
AD36	V <sub>TT</sub>	Power/Other
AG1	V <sub>TT</sub>	Power/Other
AH20	V <sub>TT</sub>	Power/Other
AK16	V <sub>TT</sub>	Power/Other
AL13	V <sub>TT</sub>	Power/Other
AL21	V <sub>TT</sub>	Power/Other
AN11	V <sub>TT</sub>	Power/Other
AN15	V <sub>TT</sub>	Power/Other
E23	V <sub>TT</sub>	Power/Other
G35	V <sub>TT</sub>	Power/Other
G37	V <sub>TT</sub>	Power/Other
S33	V <sub>TT</sub>	Power/Other
X34	V <sub>TT</sub>	Power/Other
AA33	V <sub>TT</sub>	Power/Other
AA35	V <sub>TT</sub>	Power/Other
AN21	V <sub>TT</sub>	Power/Other
S37	V <sub>TT</sub>	Power/Other
U35	V <sub>TT</sub>	Power/Other
U37	V <sub>TT</sub>	Power/Other
AK4	V <sub>TT_PWRGD</sub>	Power/Other

**Table 37. Signal Listing in Order by Pin Number**

Pin No.	Pin Name	Signal Group
A3	D29#	AGTL I/O
A5	D28#	AGTL I/O
A7	D43#	AGTL I/O
A9	D37#	AGTL I/O
A11	D44#	AGTL I/O
A13	D51#	AGTL I/O
A15	D47#	AGTL I/O
A17	D48#	AGTL I/O
A19	D57#	AGTL I/O
A21	D46#	AGTL I/O
A23	D53#	AGTL I/O
A25	D60#	AGTL I/O
A27	D61#	AGTL I/O
A29	DEP7#	AGTL I/O
A31	DEP3#	AGTL I/O
A33	DEP2#	AGTL I/O
A35	PRDY#	AGTL Output
A37	Vss	Power/Other
AA1	A27#	AGTL I/O
AA3	A30#	AGTL I/O
AA5	VCC <sub>CORE</sub>	Power/Other
AA33	VTT	Power/Other
AA35	VTT	Power/Other
AA37	VCC <sub>CORE</sub>	Power/Other
AB2	VCC <sub>CORE</sub>	Power/Other
AB4	A24#	AGTL I/O
AB6	A23#	AGTL I/O
AB32	Vss	Power/Other
AB34	VCC <sub>CORE</sub>	Power/Other
AB36	VTT	Power/Other
AC1	A33#	AGTL I/O
AC3	A20#	AGTL I/O
AC5	Vss	Power/Other
AC33	Vss	Power/Other
AC35	FERR#	CMOS Output
AC37	RSP#	AGTL Input
AD2	Vss	Power/Other
AD4	A31#	AGTL I/O
AD6	V <sub>REF5</sub>	Power/Other
AD32	VCC <sub>CORE</sub>	Power/Other

**Table 37. Signal Listing in Order by Pin Number (Continued)**

Pin No.	Pin Name	Signal Group
AD34	Vss	Power/Other
AD36	VTT	Power/Other
AE1	A17#	AGTL I/O
AE3	A22#	AGTL I/O
AE5	VCC <sub>CORE</sub>	Power/Other
AE33	A20M#	CMOS Input
AE35	IERR#	CMOS Output
AE37	FLUSH#	CMOS Input
AF2	VCC <sub>CORE</sub>	Power/Other
AF4	A35#	AGTL I/O
AF6	A25#	AGTL I/O
AF32	Vss	Power/Other
AF34	VCC <sub>CORE</sub>	Power/Other
AF36	DETECT	Power/Other
AG1	VTT	Power/Other
AG3	A19#	AGTL I/O
AG5	Vss	Power/Other
AG33	INIT#	CMOS Input
AG35	STPCLK#	CMOS Input
AG37	IGNNE#	CMOS Input
AH2	Vss	Power/Other
AH4	RESET#	AGTL Input
AH6	A10#	AGTL I/O
AH8	A5#	AGTL I/O
AH10	A8#	AGTL I/O
AH12	A4#	AGTL I/O
AH14	BNR#	AGTL I/O
AH16	REQ1#	AGTL I/O
AH18	REQ2#	AGTL I/O
AH20	VTT	Power/Other
AH22	RS1#	AGTL Input
AH24	VCC <sub>CORE</sub>	Power/Other
AH26	RS0#	AGTL + Input
AH28	THERMTRIP#	CMOS Output
AH30	SLP#	CMOS Input
AH32	VCC <sub>CORE</sub>	Power/Other
AH34	Vss	Power/Other
AH36	VCC <sub>CORE</sub>	Power/Other
AJ1	A21#	AGTL I/O
AJ3	RESET2#	AGTL Input

Table 37. Signal Listing in Order by Pin Number (Continued)

Pin No.	Pin Name	Signal Group
AJ5	VCC <sub>CORE</sub>	Power/Other
AJ7	Vss	Power/Other
AJ9	VCC <sub>CORE</sub>	Power/Other
AJ11	Vss	Power/Other
AJ13	VCC <sub>CORE</sub>	Power/Other
AJ15	Vss	Power/Other
AJ17	VCC <sub>CORE</sub>	Power/Other
AJ19	Vss	Power/Other
AJ21	VCC <sub>CORE</sub>	Power/Other
AJ23	Vss	Power/Other
AJ25	VCC <sub>CORE</sub>	Power/Other
AJ27	Vss	Power/Other
AJ29	VCC <sub>CORE</sub>	Power/Other
AJ31	BSEL1	3.3V Output
AJ33	BSEL0	3.3V Output
AJ35	SMI#	CMOS Input
AJ37	VID3	3.3V Output
AK2	VCC <sub>CORE</sub>	Power/Other
AK4	VTT_PWRGD	Power/Other
AK6	A28#	AGTL I/O
AK8	A3#	AGTL I/O
AK10	A11#	AGTL I/O
AK12	V <sub>REF6</sub>	Power/Other
AK14	A14#	AGTL I/O
AK16	VTT	Power/Other
AK18	REQ0#	AGTL I/O
AK20	LOCK#	AGTL I/O
AK22	V <sub>CMOS_REF</sub>	Power/Other
AK24	AERR#	AGTL I/O
AK26	PWRGOOD	CMOS Input
AK28	RS2#	AGTL Input
AK30	Reserved	Reserved for future use
AK32	TMS	TAP Input
AK34	VCC <sub>CORE</sub>	Power/Other
AK36	VID 25mV	3.3V Output
AL1	Reserved	Reserved for future use
AL3	Vss	Power/Other
AL5	A15#	AGTL I/O
AL7	A13#	AGTL I/O
AL9	A9#	AGTL I/O

Table 37. Signal Listing in Order by Pin Number (Continued)

Pin No.	Pin Name	Signal Group
AL11	AP0#	AGTL I/O
AL13	VTT	Power/Other
AL15	A7#	AGTL I/O
AL17	REQ4#	AGTL I/O
AL19	REQ3#	AGTL I/O
AL21	VTT	Power/Other
AL23	HITM#	AGTL I/O
AL25	HIT#	AGTL I/O
AL27	DBSY#	AGTL I/O
AL29	THERMDN	Power/Other
AL31	THERMDP	Power/Other
AL33	TCK	TAP Input
AL35	VID0	3.3V Output
AL37	VID2	3.3V Output
AM2	KEY	Power/Other
AM4	VCC <sub>CORE</sub>	Power/Other
AM6	Vss	Power/Other
AM8	VCC <sub>CORE</sub>	Power/Other
AM10	Vss	Power/Other
AM12	VCC <sub>CORE</sub>	Power/Other
AM14	Vss	Power/Other
AM16	VCC <sub>CORE</sub>	Power/Other
AM18	Vss	Power/Other
AM20	VCC <sub>CORE</sub>	Power/Other
AM22	Vss	Power/Other
AM24	VCC <sub>CORE</sub>	Power/Other
AM26	Vss	Power/Other
AM28	VCC <sub>CORE</sub>	Power/Other
AM30	Vss	Power/Other
AM32	VCC <sub>CORE</sub>	Power/Other
AM34	Vss	Power/Other
AM36	VID1	3.3V Output
AN3	DYN_OE	Power/Other
AN5	A12#	AGTL I/O
AN7	A16#	AGTL I/O
AN9	A6#	AGTL I/O
AN11	VTT	Power/Other
AN13	AP1#	AGTL I/O
AN15	VTT	Power/Other
AN17	BPRI#	AGTL Input



**Table 37. Signal Listing in Order by Pin Number (Continued)**

Pin No.	Pin Name	Signal Group
AN19	DEFER#	AGTL Input
AN21	VTT	Power/Other
AN23	RP#	AGTL I/O
AN25	TRDY#	AGTL Input
AN27	DRDY#	AGTL I/O
AN29	BR0#	AGTL I/O
AN31	ADS#	AGTL I/O
AN33	TRST#	TAP Input
AN35	TDI	TAP Input
AN37	TDO	TAP Output
B2	D35#	AGTL I/O
B4	Vss	Power/Other
B6	VCC <sub>CORE</sub>	Power/Other
B8	Vss	Power/Other
B10	VCC <sub>CORE</sub>	Power/Other
B12	Vss	Power/Other
B14	VCC <sub>CORE</sub>	Power/Other
B16	Vss	Power/Other
B18	VCC <sub>CORE</sub>	Power/Other
B20	Vss	Power/Other
B22	VCC <sub>CORE</sub>	Power/Other
B24	Vss	Power/Other
B26	VCC <sub>CORE</sub>	Power/Other
B28	Vss	Power/Other
B30	VCC <sub>CORE</sub>	Power/Other
B32	Vss	Power/Other
B34	VCC <sub>CORE</sub>	Power/Other
B36	BINIT#	AGTL I/O
C1	D33#	AGTL I/O
C3	VCC <sub>CORE</sub>	Power/Other
C5	D31#	AGTL I/O
C7	D34#	AGTL I/O
C9	D36#	AGTL I/O
C11	D45#	AGTL I/O
C13	D49#	AGTL I/O
C15	D40#	AGTL I/O
C17	D59#	AGTL I/O
C19	D55#	AGTL I/O
C21	D54#	AGTL I/O
C23	D58#	AGTL I/O

**Table 37. Signal Listing in Order by Pin Number (Continued)**

Pin No.	Pin Name	Signal Group
C25	D50#	AGTL I/O
C27	D56#	AGTL I/O
C29	DEP5#	AGTL I/O
C31	DEP1#	AGTL I/O
C33	DEP0#	AGTL I/O
C35	BPM0#	AGTL I/O
C37	CPUPRES#	Power/Other
D2	Vss	Power/Other
D4	Vss	Power/Other
D6	VCC <sub>CORE</sub>	Power/Other
D8	D38#	AGTL I/O
D10	D39#	AGTL I/O
D12	D42#	AGTL I/O
D14	D41#	AGTL I/O
D16	D52#	AGTL I/O
D18	Vss	Power/Other
D20	VCC <sub>CORE</sub>	Power/Other
D22	Vss	Power/Other
D24	VCC <sub>CORE</sub>	Power/Other
D26	Vss	Power/Other
D28	VCC <sub>CORE</sub>	Power/Other
D30	Vss	Power/Other
D32	VCC <sub>CORE</sub>	Power/Other
D34	Vss	Power/Other
D36	VCC <sub>CORE</sub>	Power/Other
E1	D26#	AGTL I/O
E3	D25#	AGTL I/O
E5	VCC <sub>CORE</sub>	Power/Other
E7	Vss	Power/Other
E9	VCC <sub>CORE</sub>	Power/Other
E11	Vss	Power/Other
E13	VCC <sub>CORE</sub>	Power/Other
E15	Vss	Power/Other
E17	VCC <sub>CORE</sub>	Power/Other
E19	Vss	Power/Other
E21	Reserved	Reserved for future use
E23	VTT <sup>4</sup>	Power/Other
E25	D62#	AGTL I/O
E27	SLEWCTRL	Power/Other
E29	DEP6#	AGTL I/O

**Table 37. Signal Listing in Order by Pin Number (Continued)**

Pin No.	Pin Name	Signal Group
E31	DEP4#	AGTL I/O
E33	V <sub>REF0</sub>	Power/Other
E35	BPM1#	AGTL I/O
E37	BP3#	AGTL I/O
F2	V <sub>CC</sub> CORE	Power/Other
F4	V <sub>CC</sub> CORE	Power/Other
F6	D32#	AGTL I/O
F8	D22#	AGTL I/O
F10	Reserved	Reserved for future use
F12	D27#	AGTL I/O
F14	V <sub>CC</sub> CORE	Power/Other
F16	D63#	AGTL I/O
F18	V <sub>REF1</sub>	Power/Other
F20	V <sub>SS</sub>	Power/Other
F22	V <sub>CC</sub> CORE	Power/Other
F24	V <sub>SS</sub>	Power/Other
F26	V <sub>CC</sub> CORE	Power/Other
F28	V <sub>SS</sub>	Power/Other
F30	V <sub>CC</sub> CORE	Power/Other
F32	V <sub>SS</sub>	Power/Other
F34	V <sub>CC</sub> CORE	Power/Other
F36	V <sub>SS</sub>	Power/Other
G1	D21#	AGTL I/O
G3	D23#	AGTL I/O
G5	V <sub>SS</sub>	Power/Other
G33	BP2#	AGTL I/O
G35	V <sub>TT</sub>	Power/Other
G37	V <sub>TT</sub>	Power/Other
H2	V <sub>SS</sub>	Power/Other
H4	D16#	AGTL I/O
H6	D19#	AGTL I/O
H32	V <sub>CC</sub> CORE	Power/Other
H34	V <sub>SS</sub>	Power/Other
H36	V <sub>CC</sub> CORE	Power/Other
J1	D7#	AGTL I/O
J3	D30#	AGTL I/O
J5	V <sub>CC</sub> CORE	Power/Other
J33	PICCLK	APIC Clock Input
J35	PICD0	APIC I/O
J37	PREQ#	CMOS Input

**Table 37. Signal Listing in Order by Pin Number (Continued)**

Pin No.	Pin Name	Signal Group
K2	V <sub>CC</sub> CORE	Power/Other
K4	V <sub>REF2</sub>	Power/Other
K6	D24#	AGTL I/O
K32	V <sub>CC</sub> CORE	Power/Other
K34	V <sub>CC</sub> CORE	Power/Other
K36	V <sub>SS</sub>	Power/Other
L1	D13#	AGTL I/O
L3	D20#	AGTL I/O
L5	V <sub>SS</sub>	Power/Other
L33	Reserved	Reserved for future use
L35	PICD1	APIC I/O
L37	LINT1/NMI	CMOS Input
M2	V <sub>SS</sub>	Power/Other
M4	D11#	AGTL I/O
M6	D3#	AGTL I/O
M32	V <sub>CC</sub> CORE	Power/Other
M34	V <sub>SS</sub>	Power/Other
M36	LINT0/INTR	CMOS Input
N1	D2#	AGTL I/O
N3	D14#	AGTL I/O
N5	V <sub>CC</sub> CORE	Power/Other
N33	Reserved	Reserved for future use
N35	Reserved	Reserved for future use
Q33	Reserved	Reserved for future use
P2	V <sub>CC</sub> CORE	Power/Other
P4	D18#	AGTL I/O
P6	D9#	AGTL I/O
P32	V <sub>SS</sub>	Power/Other
P34	V <sub>CC</sub> CORE	Power/Other
P36	V <sub>SS</sub>	Power/Other
Q1	D12#	AGTL I/O
Q3	D10#	AGTL I/O
Q5	V <sub>SS</sub>	Power/Other
N37	NCHCTRL	Power/Other
Q35	Reserved	Reserved for future use
Q37	Reserved	Reserved for future use
R2	Reserved	Reserved for future use
R4	D17#	AGTL I/O
R6	V <sub>REF3</sub>	Power/Other
R32	V <sub>CC</sub> CORE	Power/Other



**Table 37. Signal Listing in Order by Pin Number (Continued)**

Pin No.	Pin Name	Signal Group
R34	Vss	Power/Other
R36	VCC <sub>CORE</sub>	Power/Other
S1	D8#	AGTL I/O
S3	D5#	AGTL I/O
S5	VCC <sub>CORE</sub>	Power/Other
S33	VTT	Power/Other
S35	RTTCTRL	Power/Other
S37	VTT	Power/Other
T2	VCC <sub>CORE</sub>	Power/Other
T4	D1#	AGTL I/O
T6	D6#	AGTL I/O
T32	Vss	Power/Other
T34	VCC <sub>CORE</sub>	Power/Other
T36	Vss	Power/Other
U1	D4#	AGTL I/O
U3	D15#	AGTL I/O
U5	Vss	Power/Other
U33	PLL2	Power/Other
U35	VTT	Power/Other
U37	VTT	Power/Other
V2	Vss	Power/Other
V4	BERR#	AGTL I/O
V6	V <sub>REF4</sub>	Power/Other
V32	VCC <sub>CORE</sub>	Power/Other
V34	Vss	Power/Other

**Table 37. Signal Listing in Order by Pin Number (Continued)**

Pin No.	Pin Name	Signal Group
V36	VCC <sub>CORE</sub>	Power/Other
W1	D0#	AGTL I/O
W3	A34#	AGTL I/O
W5	VCC <sub>CORE</sub>	Power/Other
W33	PLL1	Power/Other
W35	Reserved	Reserved for future use
W37	BCLK	System Bus Clock
X2	Reserved	AGTL I/O
X4	Vss	Power/Other
X6	A32#	AGTL I/O
X32	Vss	Power/Other
X34	VTT	Power/Other
X36	Vss	Power/Other
Y1	Reserved	Reserved for future use
Y3	A26#	AGTL I/O
Y5	Vss	Power/Other
Y33	BCLK#/CLKREF	System Bus Clock
Y35	VCC <sub>CORE</sub>	Power/Other
Y37	Vss	Power/Other
Z2	Vss	Power/Other
Z4	A29#	AGTL I/O
Z6	A18#	AGTL I/O
Z32	VCC <sub>CORE</sub>	Power/Other
Z34	Vss	Power/Other
Z36	Reserved	Reserved for future use

## 6.0 Boxed Processor Specifications

The processor for the PGA370 socket is also offered as an Intel boxed processor. Intel boxed processors are intended for system integrators who build systems from motherboards and standard components. The boxed processor will be supplied with an unattached fan heatsink.

This section documents motherboard and system requirements for the fan heatsink that will be supplied with the boxed processor. This section is particularly important for OEMs that manufacture motherboards for system integrators. Unless otherwise noted, all figures in this section are dimensioned in inches. [Figure 28](#) shows a mechanical representation of the boxed Intel processor in the Flip Chip Pin Grid Array 2 (FC-PGA2) package.

**Note:** Drawings in this section reflect only the specifications on the Intel Boxed Processor product. These dimensions should not be used as a generic keep-out zone for all heatsinks. It is the system designer's responsibility to consider their proprietary solution when designing to the required keep-out zone on their system platform and chassis. Refer to the *Intel® Pentium® III processor Thermal/Mechanical Functional Specification* for further guidance. Contact your local Intel Sales Representative for this document.

**Figure 28. Conceptual Boxed Processor for the PGA370 Socket**

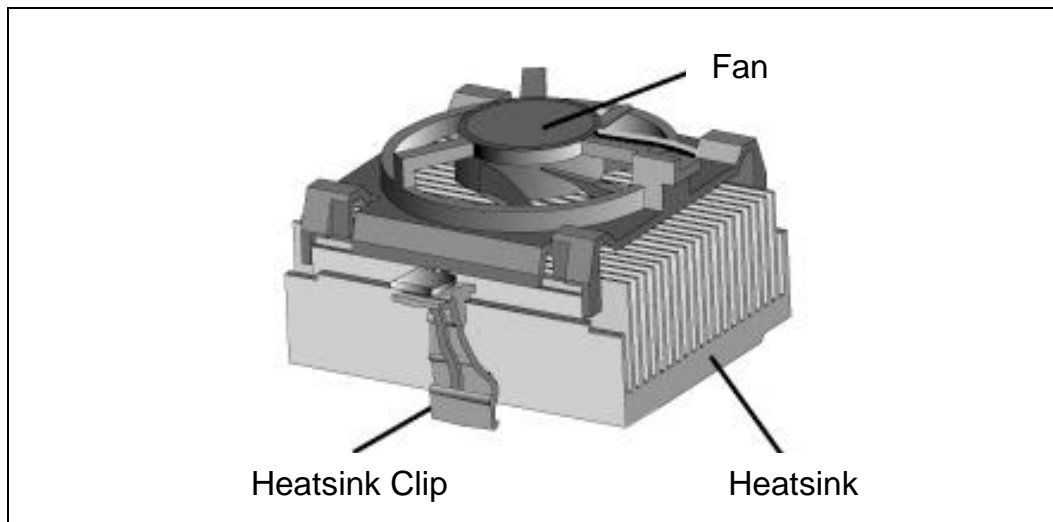

## 6.1 Mechanical Specifications

### 6.1.1 Mechanical Specifications for the FC-PGA2 Package

This section documents the mechanical specifications of the boxed processor fan heatsink in the FC-PGA2 Package. The boxed processor in the FC-PGA2 Package ships with an unattached fan heatsink. [Figure 28](#) shows a mechanical representation of the boxed processor for the PGA370 socket in the Flip Chip Pin Grid Array 2 (FC-PGA2) package.

The boxed processor fan heatsink is also asymmetrical in that the mechanical step feature, [Figure 31](#), must sit over the socket's cam. The step allows the heatsink to securely interface with the processor in order to meet the processor's thermal requirements.

The dimensions for the boxed processor with the integrated fan heatsink are shown in Figure 30. All dimensions are in inches.

The processor uses a new technology termed FC-PGA2. The FC-PGA2 package leverages the previous FC-PGA package technology used on processors based on the 0.18 micron process. The FC-PGA2 package adds an Integrated Heat Spreader (IHS) to improve heat conduction from the processor die. This new solution prevent the need for exotic thermal solutions in the higher power density processors. See section 5.0 of this document for the mechanical specifications of the PGA370 socket.

Section 5.2 of this document also shows the recommended mechanical keepout zones for the boxed processor fan heatink assembly. Figure 24 and Figure 25 show the REQUIRED keepout dimensions for the boxed processor thermal solution. The cooling fin orientation on the heatsink relative to the PGA370 socket is subject to change. Contact your local Intel Sales Representative for documentation specific to the boxed fan heatsink orientation relative to the PGA370 socket.

Figure 31 shows the changes to the package mechanicals between the FC-PGA and FC-PGA2 designs. Note that the boxed fan heatsinks and associated clips are not compatible with earlier boxed fan heatsinks for processors based on the 0.18 micron process.

Figure 29. Comparison between FC-PGA and FC-PGA2 package

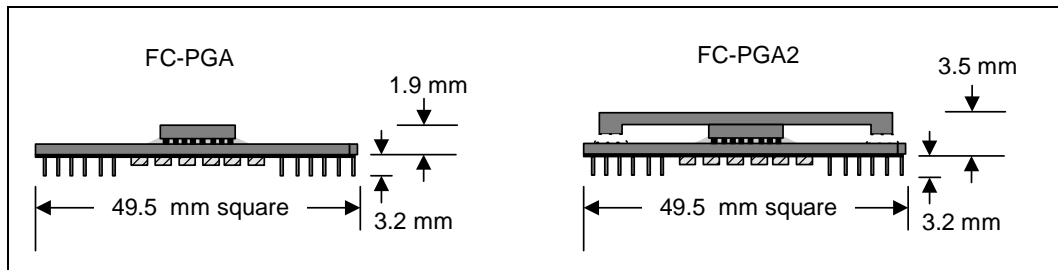
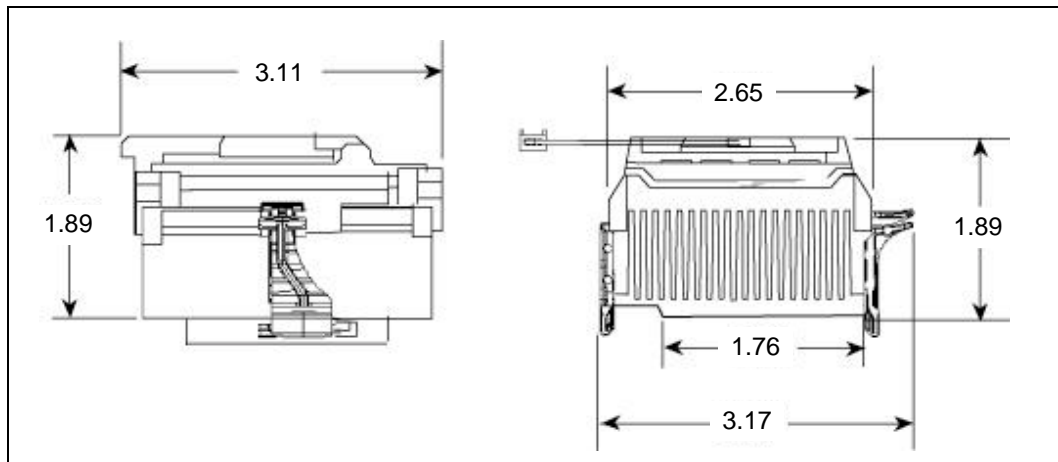

Figure 30. Side View of Space Requirements for the Boxed Processor



**Table 38. Boxed Processor Fan Heatsink Spatial Dimensions**

Dimensions (Inches)	Min	Typ	Max	Units
Fan Heatsink Length			3.14	Inches
Fan Heatsink Height			1.81	Inches
Fan Heatsink Width			2.6	Inches
Fan Heatsink height above motherboard	0.29	0.30	0.33	Inches
Air Keepout Zones from end of Fan Heatsink	0.20			Inches

**Figure 31. Dimensions of Mechanical Step Feature in Heatsink Base**

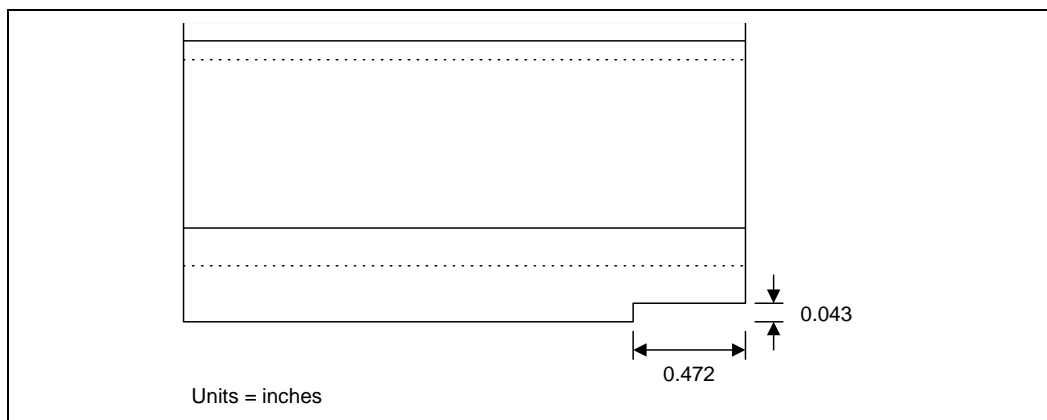

### 6.1.2 Boxed Processor Heatsink Weight

The boxed processor thermal cooling solution will not weigh more than 180 grams.

## 6.2 Thermal Specifications

This section describes the cooling requirements of the thermal cooling solution utilized by the boxed processor.

### 6.2.1 Boxed Processor Cooling Requirements

The boxed processor is directly cooled with a fan heatsink. However, meeting the processor’s temperature specification is also a function of the thermal design of the entire system and ultimately the responsibility of the system integrator. The processor temperature specification is found in [Section 4.1](#) of this document. The boxed processor fan heatsink is able to keep the processor temperature within the specifications (see [Table 30](#) in [Section 4.1](#)) in chassis that provide good thermal management.

For the boxed processor fan heatsink to operate properly, it is critical that the airflow provided to the fan heatsink is unimpeded. Airflow of the fan heatsink is into the center and out of the sides of the fan heatsink. Airspace is required around the fan to ensure that the airflow through the fan heatsink is not blocked. Blocking the airflow to the fan heatsink reduces the cooling efficiency and decreases fan life. [Figure 32](#) illustrate an acceptable airspace clearance for the fan heatsink. It is

also recommended that the air temperature entering the fan be kept below 45 degrees C. Again, meeting the processor's temperature specification is the responsibility of the system integrator. The processor temperature specification is found in [Section 4.1](#) of this document.

**Figure 32. Thermal Airspace Requirement for all Boxed Processor Fan Heatsinks in the PGA370 Socket**

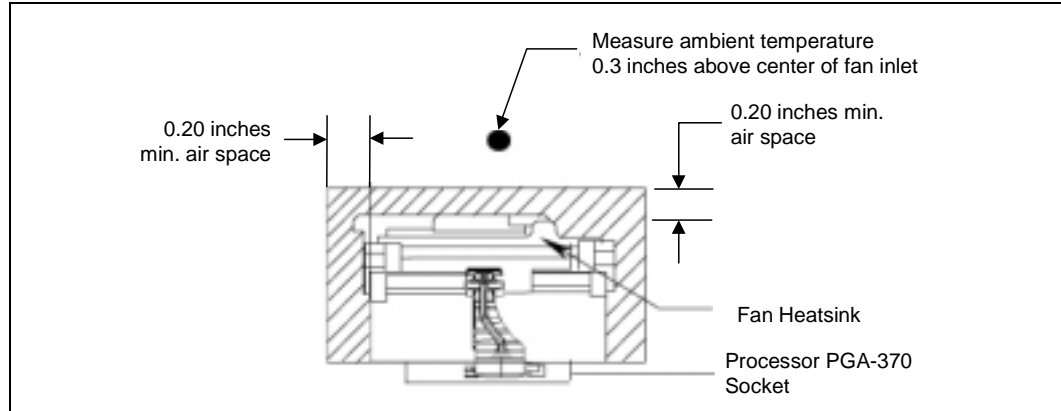

## 6.2.2 Boxed Processor Thermal Cooling Solution Clip

The boxed processor thermal solution requires installation by a system integrator to secure the thermal cooling solution to the processor after it is installed in the 370-pin socket ZIF socket. Motherboards designed for use by system integrators should take care to consider the implications of clip installation and potential scraping of the motherboard PCB underneath the 370-pin socket attach tabs. Motherboard components should not be placed too close to the 370-pin socket attach tabs in a way that interferes with the installation of the boxed processor thermal cooling solution. [Figure 24](#) and [Figure 25](#) show the REQUIRED keepout dimensions for the boxed processor thermal solution.

## 6.3 Electrical Requirements for the Boxed Processor

### 6.3.1 Electrical Requirements

The boxed processor's fan heatsink requires a +12 V power supply. A fan power cable is attached to the fan and will draw power from a power header on the motherboard. The power cable connector and pinout are shown in [Figure 33](#). Motherboards must provide a matched power header to support the boxed processor. [Table 38](#) contains specifications for the input and output signals at the fan heatsink connector. The fan heatsink outputs a SENSE signal (an open-collector output) that pulses at a rate of two pulses per fan revolution. A motherboard pull-up resistor provides VOH to match the motherboard-mounted fan speed monitor requirements, if applicable. Use of the SENSE signal is optional. If the SENSE signal is not used, pin 3 of the connector should be tied to GND.

The power header on the baseboard must be positioned to allow the fan heatsink power cable to reach it. The power header identification and location should be documented in the motherboard documentation or on the motherboard. [Figure 34](#) shows the recommended location of the fan power connector relative to the PGA370 socket. The motherboard power header should be positioned within 4.00 inches (lateral) of the fan power connector for the FC-PGA2 package.

Figure 33. Boxed Processor Fan Heatsink Power Cable Connector Description

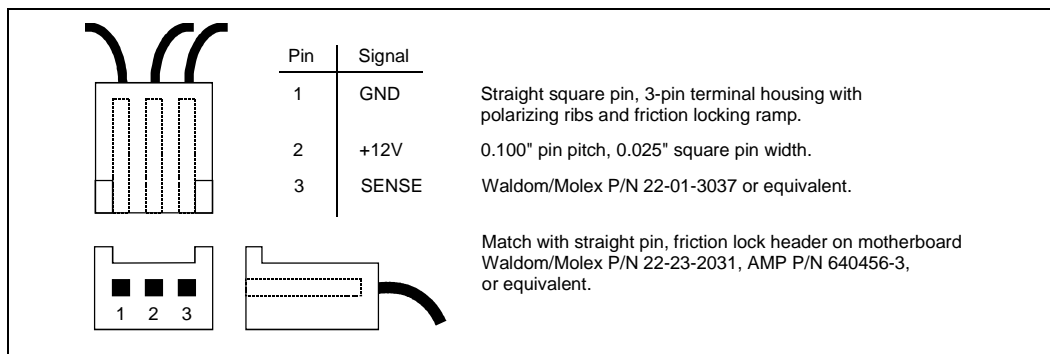
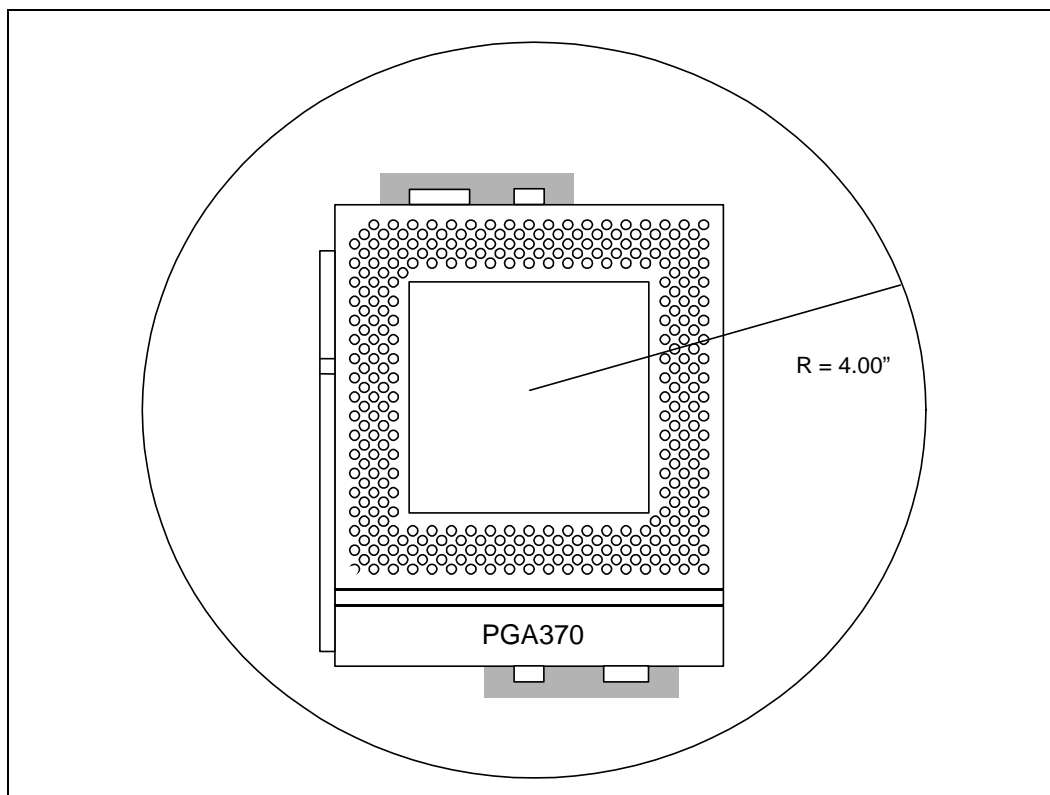

Table 39. Fan Heatsink Power and Signal Specifications

Description	Min	Typ	Max
+12 V: 12 volt fan power supply	10.8 V	12 V	13.2 V
IC: Fan current draw			100 mA
SENSE: SENSE frequency (motherboard should pull this pin up to appropriate Vcc with resistor)		2 pulses per fan revolution	

Figure 34. Motherboard Power Header Placement Relative to the Boxed Processor





## 7.0 Processor Signal Description

This section provides an alphabetical listing of all the processor signals. The tables at the end of this section summarize the signals by direction: output, input, and I/O.

### 7.1 Alphabetical Signals Reference

Table 40. Signal Description (Sheet 1 of 8)

Name	Type	Description
A20M#	I	If the A20M# (Address-20 Mask) input signal is asserted, the processor masks physical address bit 20 (A20#) before looking up a line in any internal cache and before driving a read/write transaction on the bus. Asserting A20M# emulates the 8086 processor's address wrap-around at the 1 MB boundary. Assertion of A20M# is only supported in real mode.  A20M# is an asynchronous signal. However, to ensure recognition of this signal following an I/O write instruction, it must be valid along with the TRDY# assertion of the corresponding I/O Write bus transaction.
A[35:3]#	I/O	The A[35:3]# (Address) signals define a 2 <sup>36</sup> -byte physical memory address space. When ADS# is active, these pins transmit the address of a transaction; when ADS# is inactive, these pins transmit transaction type information. These signals must connect the appropriate pins of all agents on the processor system bus. The A[35:24]# signals are parity-protected by the AP1# parity signal, and the A[23:3]# signals are parity-protected by the AP0# parity signal.  On the active-to-inactive transition of RESET#, the processors sample the A[35:3]# pins to determine their power-on configuration. See the Intel® Pentium® II Processor Developer's Manual for details.
ADS#	I/O	The ADS# (Address Strobe) signal is asserted to indicate the validity of the transaction address on the A[35:3]# pins. All bus agents observe the ADS# activation to begin parity checking, protocol checking, address decode, internal snoop, or deferred reply ID match operations associated with the new transaction. This signal must connect the appropriate pins on all processor system bus agents.
AERR#	I/O	The AERR# (Address Parity Error) signal is observed and driven by all processor system bus agents, and if used, must connect the appropriate pins on all processor system bus agents. AERR# observation is optionally enabled during power-on configuration; if enabled, a valid assertion of AERR# aborts the current transaction.  If AERR# observation is disabled during power-on configuration, a central agent may handle an assertion of AERR# as appropriate to the error handling architecture of the system.
AP[1:0]#	I/O	The AP[1:0]# (Address Parity) signals are driven by the request initiator along with ADS#, A[35:3]#, REQ[4:0]#, and RP#. AP1# covers A[35:24]#, and AP0# covers A[23:3]#. A correct parity signal is high if an even number of covered signals are low and low if an odd number of covered signals are low. This allows parity to be high when all the covered signals are high. AP[1:0]# should connect the appropriate pins of all processor system bus agents.
BCLK/BCLK#	I	The BCLK (Bus Clock) and BCLK# (for differential clock) signals determines the bus frequency. All processor system bus agents must receive this signal to drive their outputs and latch their inputs on the rising edge of BCLK. For differential clocking, all processor system bus agents must receive this signal to drive their outputs and latch their inputs on the BCLK and BCLK# crossing point.  All external timing parameters are specified with respect to the BCLK signal.

Table 40. Signal Description (Sheet 2 of 8)

Name	Type	Description
BERR#	I/O	<p>The BERR# (Bus Error) signal is asserted to indicate an unrecoverable error without a bus protocol violation. It may be driven by all processor system bus agents, and must connect the appropriate pins of all such agents, if used. However, the processor does not observe assertions of the BERR# signal.</p> <p>BERR# assertion conditions are configurable at a system level. Assertion options are defined by the following options:</p> <ul style="list-style-type: none"> <li>• Enabled or disabled.</li> <li>• Asserted optionally for internal errors along with IERR#.</li> <li>• Asserted optionally by the request initiator of a bus transaction after it observes an error.</li> <li>• Asserted by any bus agent when it observes an error in a bus transaction.</li> </ul>
BINIT#	I/O	<p>The BINIT# (Bus Initialization) signal may be observed and driven by all processor system bus agents, and if used must connect the appropriate pins of all such agents. If the BINIT# driver is enabled during power on configuration, BINIT# is asserted to signal any bus condition that prevents reliable future information.</p> <p>If BINIT# observation is enabled during power-on configuration, and BINIT# is sampled asserted, all bus state machines are reset and any data which was in transit is lost. All agents reset their rotating ID for bus arbitration to the state after Reset, and internal count information is lost. The L1 and L2 caches are not affected.</p> <p>If BINIT# observation is disabled during power-on configuration, a central agent may handle an assertion of BINIT# as appropriate to the error handling architecture of the system.</p>
BNR#	I/O	<p>The BNR# (Block Next Request) signal is used to assert a bus stall by any bus agent who is unable to accept new bus transactions. During a bus stall, the current bus owner cannot issue any new transactions.</p> <p>Since multiple agents might need to request a bus stall at the same time, BNR# is a wire-OR signal which must connect the appropriate pins of all processor system bus agents. In order to avoid wire-OR glitches associated with simultaneous edge transitions driven by multiple drivers, BNR# is activated on specific clock edges and sampled on specific clock edges.</p>
BP[3:2]#	I/O	The BP[3:2]# (Breakpoint) signals are outputs from the processor that indicate the status of breakpoints.
BPM[1:0]#	I/O	The BPM[1:0]# (Breakpoint Monitor) signals are breakpoint and performance monitor signals. They are outputs from the processor which indicate the status of breakpoints and programmable counters used for monitoring processor performance.
BPRI#	I	The BPRI# (Bus Priority Request) signal is used to arbitrate for ownership of the processor system bus. It must connect the appropriate pins of all processor system bus agents. Observing BPRI# active (as asserted by the priority agent) causes all other agents to stop issuing new requests, unless such requests are part of an ongoing locked operation. The priority agent keeps BPRI# asserted until all of its requests are completed, then releases the bus by deasserting BPRI#.
BR0#	I/O	The BR0# (Bus Request) pins drive the BREQ[0]# signal in the system. During power-up configuration, the central agent asserts the BR0# bus signal in the system to assign the symmetric agent ID to the processor. The processor samples its BR0# pin on the active-to-inactive transition of the RESET# to obtain its symmetric agent ID. The processor asserts the BR0# pin to request the system bus. BR0# must be connected to a 10-56 $\Omega$ resistor to V <sub>SS</sub> . Refer to the platform design guide for implementation detail and resistor tolerance.

Table 40. Signal Description (Sheet 3 of 8)

Name	Type	Description									
BSEL[1:0]	O	<p>The BSEL signals are CMOS signals which are used to select the system bus frequency. A BSEL[1:0] = '01' selects a 100 MHz system bus frequency. The frequency is determined by the processor(s), chipset, and frequency synthesizer capabilities. All system bus agents must operate at the same frequency. The processor operates at 100 MHz system bus frequency.</p> <p>These signals must be pulled up to 3.3V power rail with 330 Ω – 1 KΩ resistors and provided as a frequency selection signal to the clock driver/synthesizer and chipset. Refer to the platform design guide for implementation detail and resistor tolerance.</p>									
CLKREF	I	<p>In Single-ended clock mode the CLKREF input is a filtered 1.25V supply voltage for the processor PLL. A voltage divider and decoupling solution is provided by the motherboard. See the design guide for implementation details.</p> <p>When the processor operates in differential clock mode, this signal becomes BCLK#.</p>									
CPUPRES#	O	<p>The CPUPRES# signal is defined to allow a system design to detect the presence of a processor in a PGA370 socket. Combined with the VID combination of VID[25mV,3:0]= 11111 (see Section 2.6), a system can determine if a socket is occupied, and whether a processor core is present. See the table below for states and values for determining the presence of a device.</p> <p>PGA370 Socket Occupation Truth Table</p> <table border="1"> <thead> <tr> <th>Signal</th> <th>Value</th> <th>Status</th> </tr> </thead> <tbody> <tr> <td>CPUPRES# VID[25mV,3:0]</td> <td>0 Anything other than '11111'</td> <td>Processor core installed in the PGA370 socket.</td> </tr> <tr> <td>CPUPRES# VID[25mV,3:0]</td> <td>1 Any value</td> <td>PGA370 socket not occupied.</td> </tr> </tbody> </table>	Signal	Value	Status	CPUPRES# VID[25mV,3:0]	0 Anything other than '11111'	Processor core installed in the PGA370 socket.	CPUPRES# VID[25mV,3:0]	1 Any value	PGA370 socket not occupied.
Signal	Value	Status									
CPUPRES# VID[25mV,3:0]	0 Anything other than '11111'	Processor core installed in the PGA370 socket.									
CPUPRES# VID[25mV,3:0]	1 Any value	PGA370 socket not occupied.									
D[63:0]#	I/O	<p>The D[63:0]# (Data) signals are the data signals. These signals provide a 64-bit data path between the processor system bus agents, and must connect the appropriate pins on all such agents. The data driver asserts DRDY# to indicate a valid data transfer.</p>									
DBSY#	I/O	<p>The DBSY# (Data Bus Busy) signal is asserted by the agent responsible for driving data on the processor system bus to indicate that the data bus is in use. The data bus is released after DBSY# is deasserted. This signal must connect the appropriate pins on all processor system bus agents.</p>									
DEFER#	I	<p>The DEFER# signal is asserted by an agent to indicate that a transaction cannot be guaranteed in-order completion. Assertion of DEFER# is normally the responsibility of the addressed memory or I/O agent. This signal must connect the appropriate pins of all processor system bus agents.</p>									
DEP[7:0]#	I/O	<p>The DEP[7:0]# (Data Bus ECC Protection) signals provide optional ECC protection for the data bus. They are driven by the agent responsible for driving D[63:0]#, and must connect the appropriate pins of all processor system bus agents which use them. The DEP[7:0]# signals are enabled or disabled for ECC protection during power on configuration.</p>									
DETECT	O	<p>A tri-state (high-impedance) output. Can be used for platforms that need to differentiate the previous generation Intel Celeron processors for the PGA370 socket that support V<sub>TT</sub> = 1.50 V from the new processors (AF36=VSS) that support V<sub>TT</sub> = 1.25 V . The output on this signal is stable when V<sub>TT</sub> is stable. Refer to the appropriate Platform Design Guide for implementation details.</p>									
DRDY#	I/O	<p>The DRDY# (Data Ready) signal is asserted by the data driver on each data transfer, indicating valid data on the data bus. In a multi-cycle data transfer, DRDY# may be deasserted to insert idle clocks. This signal must connect the appropriate pins of all processor system bus agents.</p>									

Table 40. Signal Description (Sheet 4 of 8)

Name	Type	Description
DYN_OE	I	The DYN_OE allows the BSEL and VID signals to be driven out from the processor. When this signal is low (a condition that will occur if the processor is installed in a non-supported platform), the VID and BSEL signals will be tri-stated and the platform pull-up resistors will set the VID and BSEL to all 1s which is a safe setting. This signal must be connected to a 1 k $\Omega$ resistor to VTT. Refer to the platform design guide for implementation detail and resistor tolerance.
FERR#	O	The FERR# (Floating-point Error) signal is asserted when the processor detects an unmasked floating-point error. FERR# is similar to the ERROR# signal on the Intel 387 coprocessor, and is included for compatibility with systems using MS-DOS*-type floating-point error reporting.
FLUSH#	I	When the FLUSH# input signal is asserted, processors write back all data in the Modified state from their internal caches and invalidate all internal cache lines. At the completion of this operation, the processor issues a Flush Acknowledge transaction. The processor does not cache any new data while the FLUSH# signal remains asserted.  FLUSH# is an asynchronous signal. However, to ensure recognition of this signal following an I/O write instruction, it must be valid along with the TRDY# assertion of the corresponding I/O Write bus transaction.  On the active-to-inactive transition of RESET#, each processor samples FLUSH# to determine its power-on configuration. See the <i>P6 Family of Processors Hardware Developer's Manual</i> for details.  This signal must be connected to a 150 $\Omega$ resistor to VCC <sub>CMOS1.5</sub> . Refer to the platform design guide for implementation detail and resistor tolerance.
HIT# HITM#	I/O I/O	The HIT# (Snoop Hit) and HITM# (Hit Modified) signals convey transaction snoop operation results, and must connect the appropriate pins of all processor system bus agents. Any such agent may assert both HIT# and HITM# together to indicate that it requires a snoop stall, which can be continued by reasserting HIT# and HITM# together.
IERR#	O	The IERR# (Internal Error) signal is asserted by a processor as the result of an internal error. Assertion of IERR# is usually accompanied by a SHUTDOWN transaction on the processor system bus. This transaction may optionally be converted to an external error signal (e.g., NMI) by system core logic. The processor will keep IERR# asserted until the assertion of RESET#, BINIT#, or INIT#.
IGNNE#	I	The IGNNE# (Ignore Numeric Error) signal is asserted to force the processor to ignore a numeric error and continue to execute noncontrol floating-point instructions. If IGNNE# is deasserted, the processor generates an exception on a noncontrol floating-point instruction if a previous floating-point instruction caused an error. IGNNE# has no effect when the NE bit in control register 0 is set.  IGNNE# is an asynchronous signal. However, to ensure recognition of this signal following an I/O write instruction, it must be valid along with the TRDY# assertion of the corresponding I/O Write bus transaction.
INIT#	I	The INIT# (Initialization) signal, when asserted, resets integer registers inside all processors without affecting their internal (L1 or L2) caches or floating-point registers. Each processor then begins execution at the power-on Reset vector configured during power-on configuration. The processor continues to handle snoop requests during INIT# assertion. INIT# is an asynchronous signal and must connect the appropriate pins of all processor system bus agents.  If INIT# is sampled active on the active to inactive transition of RESET#, then the processor executes its Built-in Self-Test (BIST).
KEY	I	Can be used to prevent legacy processors from booting in incompatible platforms. Legacy processors use this pin as a RESET and should be tied to ground for a 0.13 micron process processor only platform but for flexible platform implementations this pin should be a No Connect. Please refer to the appropriate Platform Design Guide for implementation details.

Table 40. Signal Description (Sheet 5 of 8)

Name	Type	Description
LINT[1:0]	I	The LINT[1:0] (Local APIC Interrupt) signals must connect the appropriate pins of all APIC Bus agents, including all processors and the core logic or I/O APIC component. When the APIC is disabled, the LINT0 signal becomes INTR, a maskable interrupt request signal, and LINT1 becomes NMI, a nonmaskable interrupt. INTR and NMI are backward compatible with the signals of those names on the Intel Pentium processor. Both signals are asynchronous.  Both of these signals must be software configured via BIOS programming of the APIC register space to be used either as NMI/INTR or LINT[1:0]. Because the APIC is enabled by default after Reset, operation of these pins as LINT[1:0] is the default configuration.
LOCK#	I/O	The LOCK# signal indicates to the system that a transaction must occur atomically. This signal must connect the appropriate pins of all processor system bus agents. For a locked sequence of transactions, LOCK# is asserted from the beginning of the first transaction end of the last transaction.  When the priority agent asserts BPRI# to arbitrate for ownership of the processor system bus, it will wait until it observes LOCK# deasserted. This enables symmetric agents to retain ownership of the processor system bus throughout the bus locked operation and ensure the atomicity of lock.
NCHCTRL	I	The NCHCTRL input signal provides AGTL pull-down strength control. The processor samples this input to determine the N-channel device strength for pull-down when it is the driving agent. This signal must be connected to a 140hm resistor to VTT. Refer to the platform design guide for implementation detail and resistor tolerance.
PICCLK	I	The PICCLK (APIC Clock) signal is an input clock to the processor and core logic or I/O APIC which is required for operation of all processors, core logic, and I/O APIC components on the APIC bus.
PICD[1:0]	I/O	The PICD[1:0] (APIC Data) signals are used for bidirectional serial message passing on the APIC bus, and must connect the appropriate pins of all processors and core logic or I/O APIC components on the APIC bus.
PLL1, PLL2	I	The processor has an internal analog PLL clock generator that requires a quiet power supply. PLL1 and PLL2 are inputs to this PLL and must be connected to VCC <sub>CORE</sub> through a low pass filter that minimizes jitter. See the platform design guide for implementation details.
PRDY#	O	The PRDY (Probe Ready) signal is a processor output used by debug tools to determine processor debug readiness.
PREQ#	I	The PREQ# (Probe Request) signal is used by debug tools to request debug operation of the processors.
PWRGOOD	I	The PWRGOOD (Power Good) signal is processor input. The processor requires this signal to be a clean indication that the clocks and power supplies (VCC <sub>CORE</sub> , etc.) are stable and within their specifications. Clean implies that the signal will remain low (capable of sinking leakage current), without glitches, from the time that the power supplies are turned on until they come within specification. The signal must then transition monotonically to a high state. PWRGOOD can be driven inactive at any time, but clocks and power must again be stable before a subsequent rising edge of PWRGOOD. It must also meet the minimum pulse width specification in Table 18, and be followed by a 1 ms RESET# pulse.  The PWRGOOD signal must be supplied to the processor; it is used to protect internal circuits against voltage sequencing issues. It should be driven high throughout boundary scan operation.
REQ[4:0]#	I/O	The REQ[4:0]# (Request Command) signals must connect the appropriate pins of all processor system bus agents. They are asserted by the current bus owner over two clock cycles to define the currently active transaction type.

Table 40. Signal Description (Sheet 6 of 8)

Name	Type	Description
RESET#	I	<p>Asserting the RESET# signal resets all processors to known states and invalidates their L1 and L2 caches without writing back any of their contents. For a power-on Reset, RESET# must stay active for at least one millisecond after VCC<sub>CORE</sub> and CLK have reached their proper specifications. On observing active RESET#, all processor system bus agents will deassert their outputs within two clocks.</p> <p>A number of bus signals are sampled at the active-to-inactive transition of RESET# for power-on configuration. These configuration options are described in the <i>P6 Family of Processors Hardware Developer's Manual</i> for details.</p> <p>The processor may have its outputs tristated via power-on configuration. Otherwise, if INIT# is sampled active during the active-to-inactive transition of RESET#, the processor will execute its Built-in Self-Test (BIST). Whether or not BIST is executed, the processor will begin program execution at the power on Reset vector (default 0_FFFF_FFF0h). RESET# must connect the appropriate pins of all processor system bus agents.</p> <p>RESET# is the only AGTL signal which does not have on-die termination. Therefore, it is necessary to place a discrete 56Ω resistor to VTT. Refer to the platform design guide for implementation detail and resistor tolerance.</p>
RESET2#	I	<p>RESET2# pin is provided to differentiate the processor from the previous generation Intel Celeron processor. The 0.13 micron process based processor does not use the RESET2# pin. Refer to the platform design guide for the proper connections of this signal.</p>
RP#	I/O	<p>The RP# (Request Parity) signal is driven by the request initiator, and provides parity protection on ADS# and REQ[4:0]#. It must connect the appropriate pins of all processor system bus agents.</p> <p>A correct parity signal is high if an even number of covered signals are low and low if an odd number of covered signals are low. This definition allows parity to be high when all covered signals are high.</p>
RS[2:0]#	I/O	<p>The RS[2:0]# (Response Status) signals are driven by the response agent (the agent responsible for completion of the current transaction), and must connect the appropriate pins of all processor system bus agents.</p>
RSP#	I	<p>The RSP# (Response Parity) signal is driven by the response agent (the agent responsible for completion of the current transaction) during assertion of RS[2:0]#, the signals for which RSP# provides parity protection. It must connect the appropriate pins of all processor system bus agents.</p> <p>A correct parity signal is high if an even number of covered signals are low and low if an odd number of covered signals are low. While RS[2:0]# = 000, RSP# is also high, since this indicates it is not being driven by any agent guaranteeing correct parity.</p>
RTTCTRL	I	<p>The RTTCTRL input signal provides AGTL termination control. The processor samples this input to set the termination resistance value for the on-die AGTL termination. This signal must be connected to a 56 Ω resistor to VSS on a uni-processor platform or a 68 Ω resistor to VSS on a dual-processor platform. Refer to the platform design guide for implementation detail and resistor tolerance.</p>
SLEWCTRL	I	<p>The SLEWCTRL input signal provides AGTL slew rate control. The processor samples this input to determine the slew rate for AGTL signals when it is the driving agent. This signal must be connected to a 110 Ω resistor to VSS. Refer to the platform design guide for implementation detail and resistor tolerance.</p>
SLP#	I	<p>The SLP# (Sleep) signal, when asserted in Stop-Grant state, causes processors to enter the Sleep state. During Sleep state, the processor stops providing internal clock signals to all units, leaving only the Phase-Locked Loop (PLL) still operating. Processors in this state will not recognize snoops or interrupts. The processor will recognize only assertions of the SLP#, STPCLK#, and RESET# signals while in Sleep state. If SLP# is deasserted, the processor exits Sleep state and returns to Stop-Grant state, restarting its internal clock signals to the bus and APIC processor core units.</p>

Table 40. Signal Description (Sheet 7 of 8)

Name	Type	Description
SMI#	I	The SMI# (System Management Interrupt) signal is asserted asynchronously by system logic. On accepting a System Management Interrupt, processors save the current state and enter System Management Mode (SMM). An SMI Acknowledge transaction is issued, and the processor begins program execution from the SMM handler.
STPCLK#	I	The STPCLK# (Stop Clock) signal, when asserted, causes processors to enter a low power state. The processor stops providing internal clock signals to all processor core units except the bus and APIC units. The processor continues to snoop bus transactions and latch interrupts. When STPCLK# is deasserted, the processor restarts its internal clock to all units, services pending interrupts, and resumes execution. The assertion of STPCLK# has no effect on the bus clock; STPCLK# is an asynchronous input.
TCK	I	The TCK (Test Clock) signal provides the clock input for the processor Test Bus (also known as the Test Access Port).
TDI	I	The TDI (Test Data In) signal transfers serial test data into the processor. TDI provides the serial input needed for JTAG specification support.
TDO	O	The TDO (Test Data Out) signal transfers serial test data out of the processor. TDO provides the serial output needed for JTAG specification support.
THERMDN	O	Thermal Diode Cathode. This signal is used to calculate core (junction) temperature. See Section 4.1.
THERMDP	I	Thermal Diode Anode. This signal is used to calculate core (junction) temperature. See Section 4.1.
THERMTRIP#	O	<p>The processor protects itself from catastrophic overheating by use of an internal thermal sensor. This sensor is set well above the normal operating temperature to ensure that there are no false trips. The processor will stop all execution when the junction temperature exceeds approximately 135 °C. This is signaled to the system by the THERMTRIP# (Thermal Trip) pin. Once activated, the signal remains latched, and the processor stopped, until RESET# goes active or core power is removed. There is no hysteresis built into the thermal sensor itself; as long as the die temperature drops below the trip level, a RESET# pulse will reset the processor and execution will continue. If the temperature has not dropped below the trip level, the processor will continue to drive THERMTRIP# and remain stopped.</p> <p>In the event the processor drives the THERMTRIP# signal active during valid operation, both the VCC and VTT supplies to the processor must be turned off to prevent thermal runaway of the processor. Valid operation refers to the operating conditions where the THERMTRIP# signal is guaranteed valid. The time required from THERMTRIP# asserted to VCC rail at 1/2 nominal is 5 seconds and THERMTRIP# asserted to VTT rail at 1/2 nominal is 5 seconds. Once Vcc and VTT supplies are turned off the THERMTRIP# signal will be deactivated. System logic should ensure no “unsafe” power cycling occurs due to this deassertion.</p>
TMS	I	The TMS (Test Mode Select) signal is a JTAG specification support signal used by debug tools.
TRDY#	I/O	The TRDY# (Target Ready) signal is asserted by the target to indicate that it is ready to receive a write or implicit writeback data transfer. TRDY# must connect the appropriate pins of all processor system bus agents.
TRST#	I	The TRST# (Test Reset) signal resets the Test Access Port (TAP) logic. TRST# must be driven low during power on Reset.
V <sub>CMOS_REF</sub>	I	<p>The V<sub>CMOS_REF</sub> input pin supplies non-AGTL reference voltage, which is typically 2/3 of V<sub>CMOS</sub>. V<sub>CMOS_REF</sub> is used by the non-AGTL receivers to determine if a signal is a logical 0 or a logical 1.</p> <p>The Thevenin equivalent impedance of the V<sub>CMOS_REF</sub> generation circuits must be less than 0.5 kΩ/1 kΩ (i.e., top resistor 500 Ω, bottom resistor 1 kΩ).</p>

Table 40. Signal Description (Sheet 8 of 8)

Name	Type	Description
VID [3:0,25mV]	O	The VID[3:0, 25 mV] (Voltage ID) pins can be used to support automatic selection of power supply voltages. These pins are CMOS signals that must be pulled up to 3.3 V power rail with 1 K $\Omega$ resistors. The VID pins are needed to cleanly support voltage specification variations on processors. See Table 3 for definitions of these pins. The power supply must supply the voltage that is requested by these pins, or disable itself.
V <sub>REF</sub>	I	The V <sub>REF</sub> input pins supply the AGTL reference voltage, which is typically 2/3 of VTT. V <sub>REF</sub> is used by the AGTL receivers to determine if a signal is a logical 0 or a logical 1.
VTT_PWRGD	I	The VTT_PWRGD signal informs the system that the VID/BSEL signals are in their correct logic state. During Power-up, the VID signals will be in an indeterminate state for a small period of time. The voltage regulator or the VRM should not sample and/or latch the VID signals until the VTT_PWRGD signal is asserted. The assertion of the VTT_PWRGD signal indicates the VID signals are stable and are driven to the final state by the processor. Refer to Figure 6 for power-up timing sequence for the VTT_PWRGD and the VID signals

## 7.2 Signal Summaries

Table 41 through Table 44 list attributes of the processor output, input, and I/O signals.

Table 41. Output Signals

Name	Active Level	Clock	Signal Group
BSEL[1:0]	High	Asynch	Power/Other
CPUPRES#	Low	Asynch	Power/Other
DETECT	High	Asynch	Power/Other
FERR#	Low	Asynch	CMOS Output
IERR#	Low	Asynch	CMOS Output
PRDY#	Low	BCLK	AGTL Output
TDO	High	TCK	TAP Output
THERMTRIP#	Low	Asynch	CMOS Output
VID[3:0, 25mV]	N/A	Asynch	Power/Other

Table 42. Input Signals (Sheet 1 of 2)

Name	Active Level	Clock	Signal Group	Qualified
A20M#	Low	Asynch	CMOS Input	Always <sup>1</sup>
BCLK	High	—	System Bus Clock	Always
BPRI#	Low	BCLK	AGTL Input	Always
DEFER#	Low	BCLK	AGTL Input	Always
FLUSH#	Low	Asynch	CMOS Input	Always <sup>1</sup>
IGNNE#	Low	Asynch	CMOS Input	Always <sup>1</sup>
INIT#	Low	Asynch	CMOS Input	Always <sup>1</sup>
INTR	High	Asynch	CMOS Input	APIC disabled mode
KEY	N/A	Asynch	Power/Other	



**Table 42. Input Signals (Sheet 2 of 2)**

Name	Active Level	Clock	Signal Group	Qualified
LINT[1:0]	High	Asynch	CMOS Input	APIC enabled mode
NMI	High	Asynch	CMOS Input	APIC disabled mode
NCHCTRL	N/A	Asynch	Power/Other	
PICCLK	High	—	APIC Clock	Always
PREQ#	Low	Asynch	CMOS Input	Always
PWRGOOD	High	Asynch	CMOS Input	Always
RESET#	Low	BCLK	AGTL Input	Always
RESET2#	Low	BCLK	AGTL Input	
RSP#	Low	BCLK	AGTL Input	Always
RTTCTRL	N/A	Asynch	Power/Other	
SLEWCTRL	N/A	Asynch	Power/Other	
SLP#	Low	Asynch	CMOS Input	During Stop-Grant state
SMI#	Low	Asynch	CMOS Input	
STPCLK#	Low	Asynch	CMOS Input	
TCK	High	—	TAP Input	
TDI	High	TCK	TAP Input	
TMS	High	TCK	TAP Input	
TRST#	Low	Asynch	TAP Input	
VTT_PWRGD	High	Asynch	Power/Other	

**NOTE:** Synchronous assertion with active TDRY# ensures synchronization.

**Table 43. Input/Output Signals (Single Driver)**

Name	Active Level	Clock	Signal Group	Qualified
A[35:3]#	Low	BCLK	AGTL I/O	ADS#, ADS##+1
ADS#	Low	BCLK	AGTL I/O	Always
AP[1:0]#	Low	BCLK	AGTL I/O	ADS#, ADS##+1
BP[3:2]#	Low	BCLK	AGTL I/O	Always
BPM[1:0]#	Low	BCLK	AGTL I/O	Always
BR0#	Low	BCLK	AGTL I/O	Always
D[63:0]#	Low	BCLK	AGTL I/O	DRDY#
DBSY#	Low	BCLK	AGTL I/O	Always
DEP[7:0]#	Low	BCLK	AGTL I/O	DRDY#
DRDY#	Low	BCLK	AGTL I/O	Always
LOCK#	Low	BCLK	AGTL I/O	Always
REQ[4:0]#	Low	BCLK	AGTL I/O	ADS#, ADS##+1
RP#	Low	BCLK	AGTL I/O	ADS#, ADS##+1
RS[2:0]#	Low	BCLK	AGTL Input	Always
TRDY#	Low	BCLK	AGTL Input	



**Table 44. Input/Output Signals (Multiple Driver)**

<b>Name</b>	<b>Active Level</b>	<b>Clock</b>	<b>Signal Group</b>	<b>Qualified</b>
AERR#	Low	BCLK	AGTL I/O	ADS#+3
BERR#	Low	BCLK	AGTL I/O	Always
BINIT#	Low	BCLK	AGTL I/O	Always
BNR#	Low	BCLK	AGTL I/O	Always
HIT#	Low	BCLK	AGTL I/O	Always
HITM#	Low	BCLK	AGTL I/O	Always
PICD[1:0]	High	PICCLK	APIC I/O	Always