

GIMIX™ 2 PORT RS-232C SERIAL INTERFACE
for the SS50(C) 30 pin I/O bus

FEATURES

- * TWO SEPARATE RS-232 PORTS (W/HANDSHAKE) ON A SINGLE BOARD
- * JUMPER PROGRAMMABLE CONNECTOR PINOUTS (DCE/DTE)
- * INDIVIDUAL BAUD RATE AND INTERRUPT JUMPERS FOR EACH PORT
- * CAN BE USED WITH 4 OR 16 DECODED ADDRESSES PER I/O SLOT
- * OPTIONAL CABLE SETS ALLOW DIRECT PLUG-IN OF STANDARD RS-232 CABLES AND CONNECTORS
- * USES TWO 6850 ACIAs
- * GUARANTEED 2MHz. OPERATION

HARDWARE CONFIGURATION

ADDRESS DECODING

The board can be configured for systems with either 4 or 16 decoded addresses per I/O slot by changing the location of the 74LS02 I.C. (U-7 or U-8). If the 74LS02 is installed at location U-7, the board is configured for 4 addresses per I/O slot. To configure the board for 16 addresses per I/O slot, the 74LS02 must be installed at location U-8. (see the component layout drawing for the locations of U-7 and U-8) When configured for 16 addresses per slot, the board decodes two additional lines, RS2/UD3 and RS3/UD4 .

Each of the two ACIAs, U-3('A' side) and U-4('B' side), occupy 2 bytes of the available address space, one for its control port and one for its data port. The following table shows the locations of the ports for both the 4 address per slot and the 16 address per slot configurations:

4 ADDRESSES 'LS02' at U-7	16 ADDRESSES 'LS02' at U-8
\$XXXX U-3(A) CONTROL	\$XXX0 U-3(A) CONTROL
\$XXXX+1 U-3(A) DATA	\$XXX1 U-3(A) DATA
\$XXXX+2 U-4(B) CONTROL	\$XXX2 unused
\$XXXX+3 U-4(B) DATA	\$XXX3 unused
	\$XXX4 U-4(B) CONTROL
	\$XXX5 U-4(B) DATA
	\$XXX6 unused
	"
	"
	"
	\$XXXF unused

\$XXXX = BASE ADDRESS
OF I/O SLOT

\$XXX0 = BASE ADDRESS OF I/O SLOT

CONNECTOR OPTION JUMPERS (JA-1 and JA-2)

Figure 'A' of the JUMPER CONFIGURATIONS drawing shows the pinouts of jumper areas JA-1 and JA-2. These jumpers are used to configure the pinouts of the I/O connectors, J-1 for the 'A' side and J-2 for the 'B' side, as required by the external device(s) being connected. The numbers at the top of the figure correspond to the pin numbers of the 25 pin 'D' type connector when GIMIX cable sets are used. Pins 1, 7, and 24 are permanently defined as FRAME GROUND, SIGNAL GROUND, and EXTERNAL CLOCK INPUT respectively (see figure 'E' of the JUMPER CONFIGURATION drawing).

Figures 'B', 'C', and 'D' show three common jumper configurations and their corresponding pinouts. Consult the documentation for the device(s) being connected, to determine the necessary signals and their corresponding pinouts. Figures 'B' and 'D' are most commonly used when connecting the board to a terminal or other device configured like a terminal (RS-232 Data Terminal Equipment/DTE). Figure 'C' is used when connecting to a modem or other device configured like a modem (RS-232 Data Communications Equipment/DCE).

In many cases, especially at slow baud rates, the handshake signals (CTS, DCD, and RTS) are not required. In these cases a simple three wire cable, with connections to pins 2, 3, and 7, is all that is required. Internal pull-up resistors on the handshake inputs (DCD and CTS) permit them to be left open (unconnected), when their use is not required, without affecting the operation of the system. When any of the handshake signals are not used, the corresponding jumper(s) should be removed from the board or connected to an unused (unconnected) pin(s) to prevent possible interference from other signals which may be present on the cable from the external device.

BAUD RATE SELECT JUMPERS (JA-3 AND JA-4)

Jumper areas JA-3 and JA-4 are used to select the baud rate for the 'A' and 'B' sides respectively. Each side can be connected to any one of the five baud rate lines of the 30 pin bus or to an external baud rate input on pin 24 of the I/O connector. Figure 'I' of the JUMPER CONFIGURATION drawing shows the pinouts of JA-3 and JA-4. The baud rate designations shown are the standard designations for the 30 pin bus baud rate lines. The actual baud rate(s) available on these lines will depend on the configuration of the system baud rate generator. Consult the documentation for the baud rate generator to determine the available baud rates or to configure one of the lines for a specific rate. Figure J shows the proper jumper position for connection to the 300 baud line.

If the baud rate clock is to be provided by an external source, such as a terminal or modem, the baud rate jumper(s) must be set to the EXT (external) position and the clock signal connected to pin 24 of the I/O connector. NOTE: The external clock input MUST BE A TTL LEVEL (0 to +5 Volt) signal. Although the EXT inputs are diode protected, application of signal levels outside the 0 to +5V. range may damage the diodes and/or the ACIA(s).

INTERRUPT OPTION JUMPER (JA-5)

The interrupt outputs from each of the ACIAs can be individually connected to either of the two interrupt lines of the 30 pin bus (IRQ or NMI/FIRQ). Figure 'F' of the JUMPER CONFIGURATION drawing shows the pinout of JA-5. When used with systems that do not require interrupts from the I/O devices, the interrupt jumpers should be installed as shown in figure 'G' (interrupts disabled). This is the standard configuration for use with GMXBUG-09/GIMIX FLEX™. When used with operating systems that require I/O device interrupts, such as OS-9™ or UniFLEX™, jumpers should be installed to connect the interrupt outputs to the proper bus line, IRQ or NMI/FIRQ, as required by the operating system. Consult the software vendor's documentation to determine the required interrupt. Note: The interrupt available on the line designated NMI/FIRQ will depend on the type of system and the configuration of the mother board. See the mother board and/or CPU board documentation.

HALF-DUPLEX JUMPERS (A and B)

Two additional jumper areas, labeled 'A' and 'B' on the circuit board and COMPONENT LAYOUT drawing, can be used to configure the board for half-duplex operation. If a jumper(s) are installed at these locations, the data input (RX) for the associated side is connected to the data output (TX) and the data received by the board is automatically re-transmitted to the transmitting device (terminal, modem, etc.). In most applications, the full-duplex mode is used and these jumpers should be left OPEN (unconnected).

***** IMPORTANT - PLEASE READ *****

CONFIGURATION INFORMATION FOR THE GIMIX TWO PORT SERIAL I/O BOARD

This notice outlines the recommended procedure for connecting serial peripherals (terminals, printers, etc.) to the GIMIX Two Port RS-232C serial interface board. Failure to follow the recommended procedure can result in random I/O errors caused by noise pickup on unused handshake lines (CTS and/or DCD). The errors are most noticeable on interrupt driven systems (OS-9 and UniFLEX) where noise can cause the generation of interrupts that cannot be identified by the operating system.

As shipped, the jumpers on the Two Port serial boards are normally configured as shown in figure "B" of the "JUMPER CONFIGURATIONS" drawing included with the board. The following chart shows the DB-25 connector pinouts for this configuration.

Signal	Pin#	Direction	
		Computer	Peripheral
RX	2	<-----<	
TX	3	>----->	
	4		----->
	5		[
	7	<----->	----->
GND	7	<----->	
RTS	8	>----->	
DCD	12	<-----<	
CTS	20	<-----<	

High-speed terminals normally require a simple three wire cable, without handshake, connecting pins 2,3, and 7 of the I/O board to the corresponding pins on the terminal. THE UNUSED HANDSHAKE INPUTS (DCD and CTS) MUST BE PROPERLY TERMINATED TO PREVENT NOISE PICKUP. It is especially important to terminate these inputs if a 25 conductor cable is used.

There are two recommended methods for terminating DCD and CTS. The first is to REMOVE (from JA-1 and/or JA-2) the jumpers that connect DCD and CTS to the I/O cable. These jumpers MUST BE REMOVED even if the corresponding pins on the I/O connector are unconnected since even the length of cable from the board to the back-panel connector is sufficient to pick up noise from the system. Pull-up resistors on the board force the inputs to the required active level for proper operation of the board. This method should be sufficient in most cases.

The second method connects the RTS output from the board to the DCD and CTS inputs. Using the output driver (RTS) to hold the handshake inputs at the proper level. Caution: This method will only work if the software initializes the RTS output of the ACIA to the active level. Operating systems supplied by GIMIX (FLEX, OS-9, and UniFLEX) initialize the ACIA properly. Software from other sources, that directly accesses the ACIA, should be checked for proper initialization. There are two ways to implement this method, depending on the type of cable used to connect the board and the peripheral. If a discrete-wired cable is used, jumpers can be installed in the connector at the computer end of the cable, to connect RTS, CTS, and DCD together. (In the case of the jumper configuration shown above, pins 8, 12, and 20 would be connected together) If a mass-terminated or ribbon type cable is used, the jumpers for RTS, DCD, and CTS can be removed from JA-1/JA-2 and wire-wrap techniques used to connect RTS, DCD, and CTS together at the jumper strips.

Printer interfaces normally require handshake to prevent the computer from outputting data faster than the printer can accept it. Software provided by GIMIX uses the CTS input to the serial board for printer handshaking. The CTS input must be connected to an output from the printer that is high (positive level) when the printer is ready to accept data and low (negative level) when it is not ready. The DCD input is not used in this application and should be terminated as described in the preceding section. If printer handshake is not required (if, for example, the baud rate will be set slow enough to prevent printer over-run) the CTS input should also be terminated as described above. Note: Some serial printers require that their handshake inputs (DSR/DCD) be placed in an active state before they will accept data. This can usually be accomplished by connecting an unused output from the printer (DTR) to its handshake inputs, at the printer end of the cable. See the example diagrams below and the printer documentation.

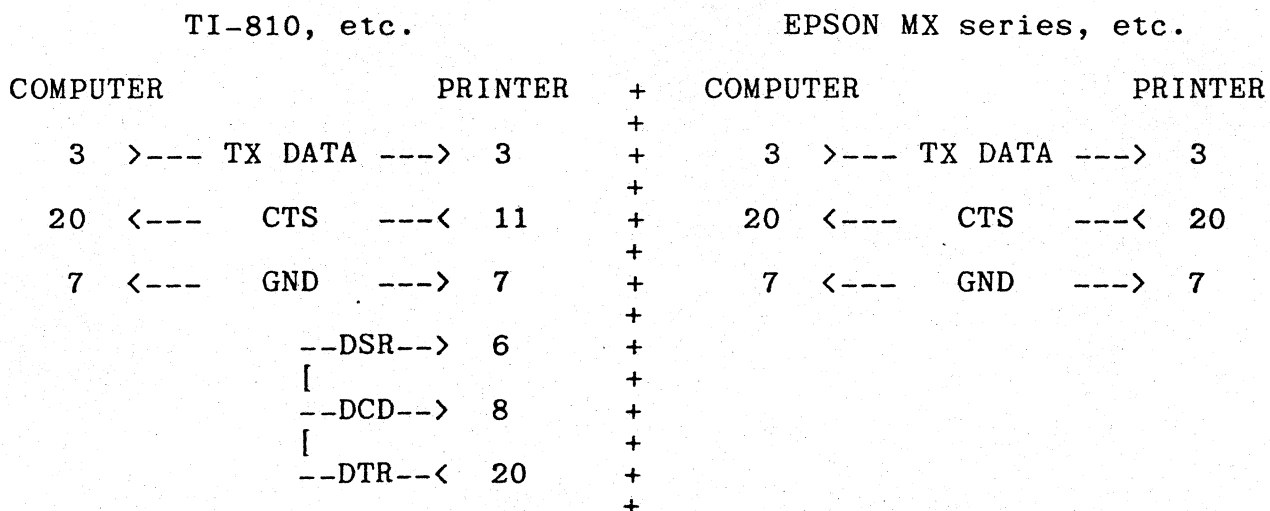

NOTE: The above diagrams assume that the 2-port serial board is jumpered as shown in figure "B" of the hardware documentation.

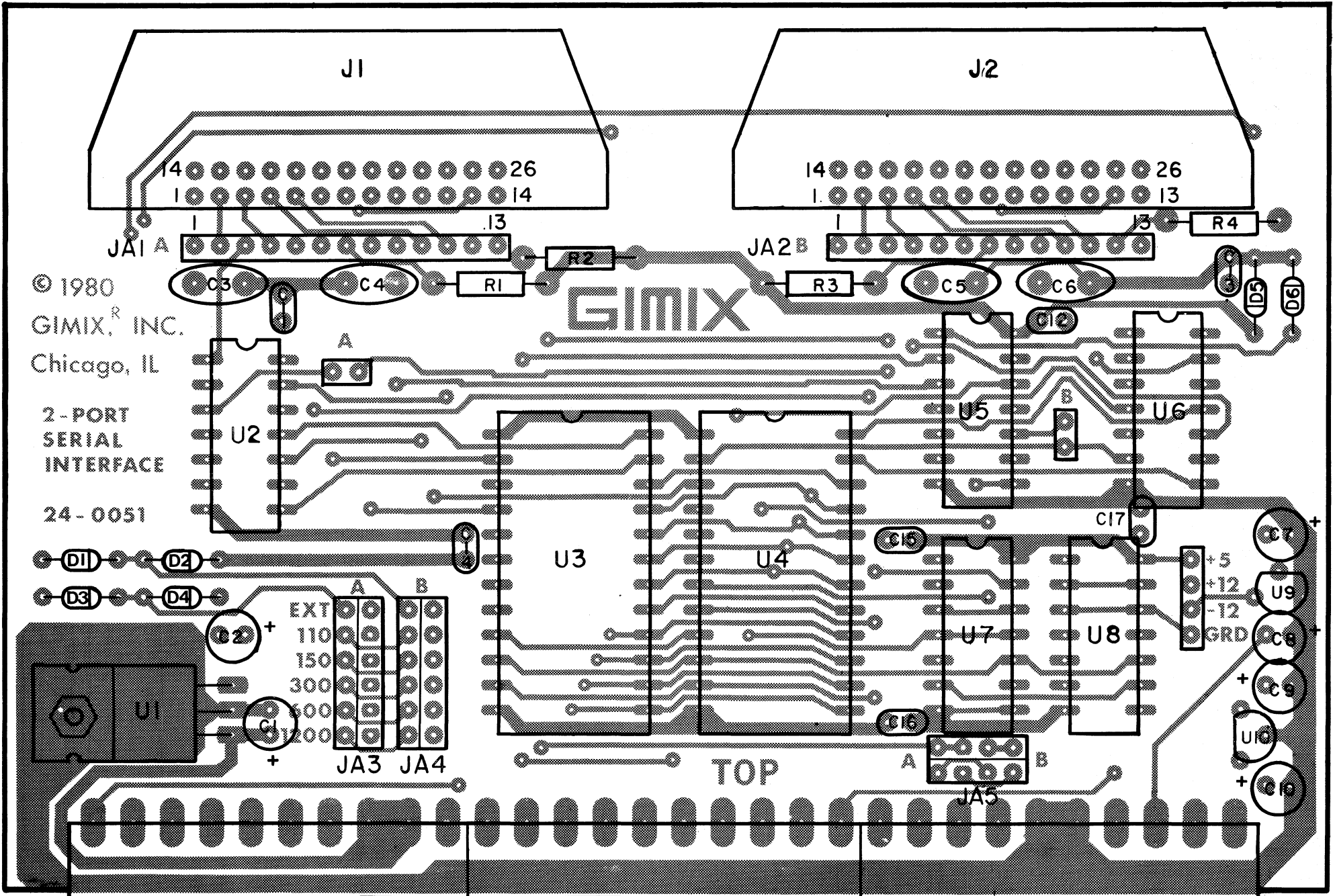

© 1980
 GIMIX, INC.
 Chicago, IL

2-PORT
 SERIAL
 INTERFACE

24-0051

COMPONENT LAYOUT

FIG. A

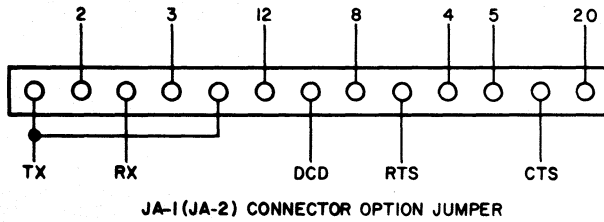

TO J-1(J-2) OR DB-25S IF GIMIX CABLES ARE INSTALLED.

FIG. B

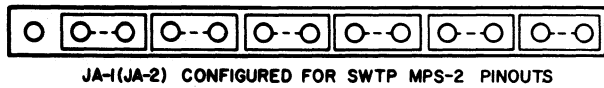

J1(J2) PIN NO.	SIGNAL (DIRECTION)
2	RECEIVE DATA (TO COMPUTER)
3	TRANSMIT DATA (FROM COMPUTER)
4 and 5	TIED TOGETHER
8	RTS (FROM COMPUTER)
12	DCD (TO COMPUTER)
20	CTS (TO COMPUTER)

FIG. C



J1(J2) PIN NO.	SIGNAL (DIRECTION)
2	TRANSMIT DATA (FROM COMPUTER)
3	RECEIVE DATA (TO COMPUTER)
4	RTS (FROM COMPUTER)
5	CTS (TO COMPUTER)
8	DCD (TO COMPUTER)

FIG. D

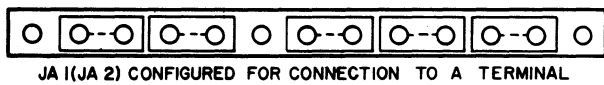

J1(J2) PIN NO.	SIGNAL (DIRECTION)
2	RECEIVE DATA (TO COMPUTER)
3	TRANSMIT DATA (FROM COMPUTER)
4	RTS (FROM COMPUTER)
5	CTS (TO COMPUTER)
8	DCD (TO COMPUTER)

FIG. F

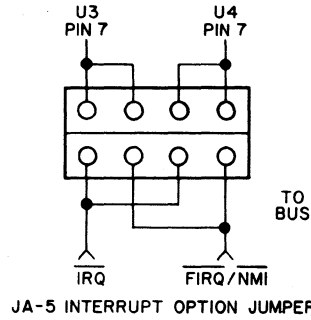

FIG. G

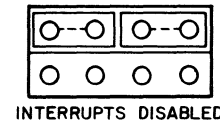
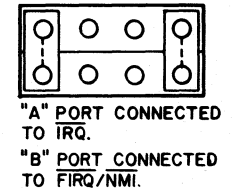

FIG. H



SAMPLE INTERRUPT JUMPER CONFIGURATIONS

NOTE: NUMBERS IN PARENTHESIS ARE FOR THE "B" PORT.

FIG. I

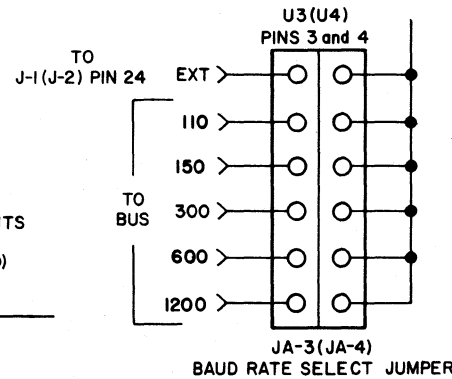

FIG. J

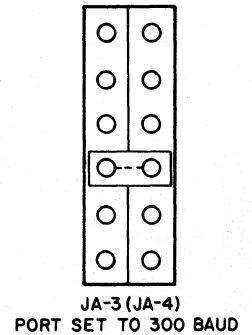

FIG. E

DB-25S CONNECTOR PINOUTS (WHEN GIMIX CABLE SET(S) ARE INSTALLED)

1	FRAME GROUND
2	*
3	*
4	*
5	*
7	SIGNAL GROUND
8	*
12	*
20	*
24	EXTERNAL CLOCK INPUT
*	JUMPER SELECTABLE PINOUTS (See figs. A-D)

NOTE: ALL OTHER PINS ARE UNUSED.

GIMIX INC.		
1337 W. 37th PLACE, CHICAGO, IL. 60609		
7-31-80	2-PORT SERIAL INTERFACE	<i>DALAS</i>
JUMPER CONFIGURATIONS		
PROPRIETARY MAT'L., ALL RIGHTS RESERVED		C24-0043
©1980 GIMIX INC.		

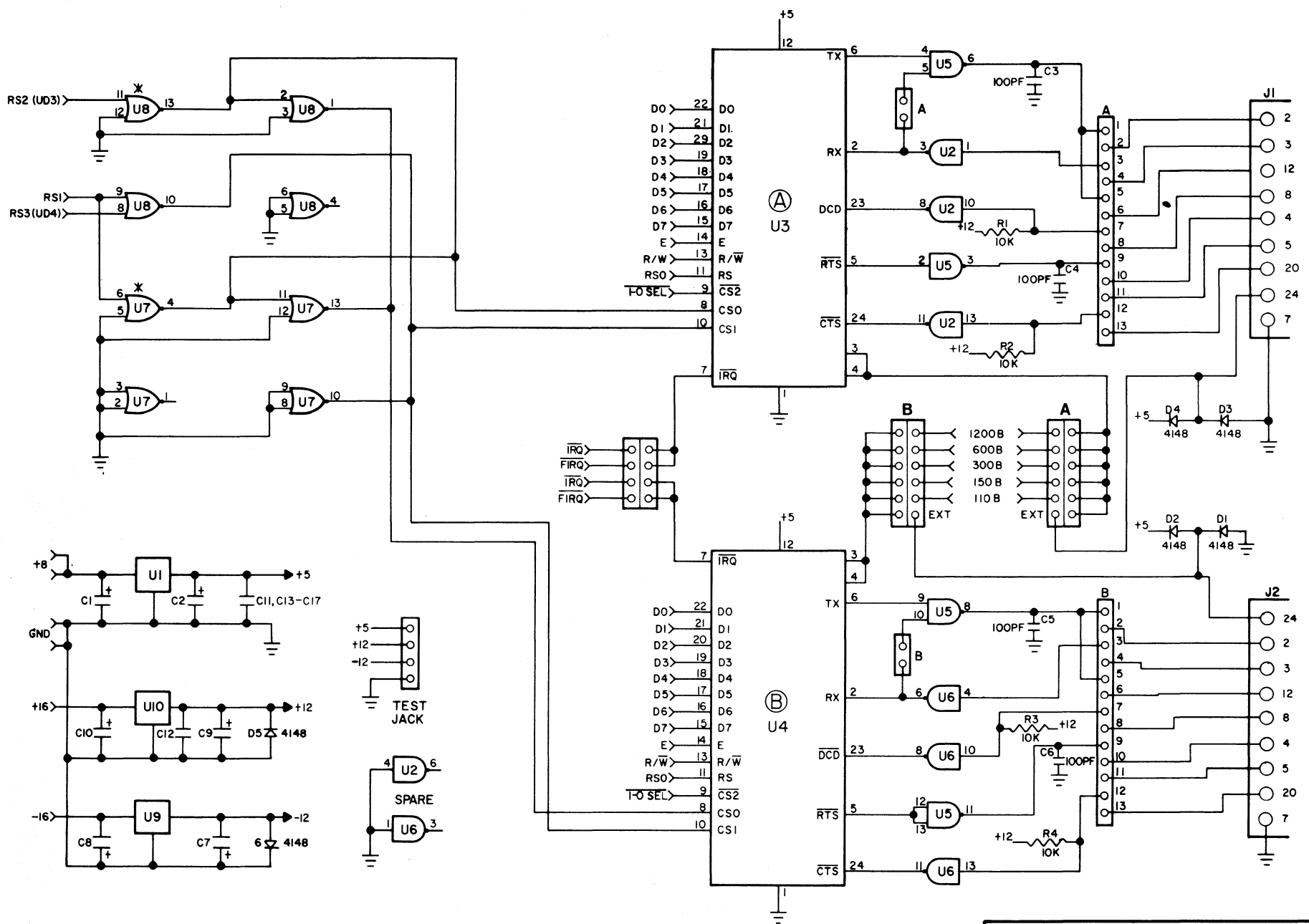

* NOTE: U7 INSTALLED FOR 4 OR 8 ADDRESSES PER I-O SLOT.
 U8 INSTALLED FOR 16 ADDRESSES PER I-O SLOT.

GIMIX INC.	
1337 W. 37th PLACE, CHICAGO, IL. 60609	
6-26-80	<i>Davis</i>
2-PORT SERIAL INTERFACE	
PROPRIETARY MATL., ALL RIGHTS RESERVED ©1980 GIMIX INC.	L24-0051