

Figure 2-29. Block Diagram, Power Supply

2.11 POWER SUPPLY, Part No. 26021-XX

The regulated power supply is provided in either of two input voltages, 115 or 220 volts. Variation of input voltage can be $\pm 15\%$ for either supply. Line frequency can be 47 to 63 Hz. An AC line fuse is located inside the desk at the bottom, and is accessible by removing the desk front panel. The POWER switch is at the right side of the keyboard.

+5V @ 4A (8A surge)

+15V @ 4A (10A surge)

-15V @ 4A (10A surge)

Foldback current limiting is provided on all output voltages (11A+2A for 5V, 13A+2A for 15V) as well as on the inverter primary. Overvoltage protection takes over when the +5 volt output reaches approximately 5.6 volts. The primary circuit, which may generate switching transients, is electrically isolated from the secondary (output) circuit.

The power supply operates on the principle of switching regulation, using a power transistor as a pulse-width-modulated switch controlled by a negative feedback loop from the output circuit. AC line voltage is rectified, chopped, smoothed, inverted at 20 kHz, then finally rectified for output to the terminal circuits. Operation at this frequency, rather than at 60 Hz, permits the use of much smaller, lighter transformers and inductors that dissipate far less heat.

2.11.1 General Description

Refer to the block diagram, Figure 2-29 and the schematic diagram, Drawing No. 26021-xx in the Schematics/Reference Section of this manual. A thermistor in the power supply input line limits power-up inrush of current to charge a large capacitor in the rectifier circuit. An input radio frequency interference (RFI) filter prevents switching transients generated by the power supply from being reflected back onto the AC line. A full-wave bridge rectifier produces approximately 100 volts DC. A portion of the rectifier output is tapped off through a resistance network to supply a local 15 volt regulated power supply that furnishes power to the primary circuit. An internal fuse at the output of the rectifier protects it from catastrophic failure of circuit elements in the primary. Raw DC from the rectifier is applied to a power transistor driven at 20 kHz by a switching regulator amplifier. Chopped DC from the power switch is smoothed in an L/C filter network. A positive feedback loop from the filter to the switch driver maintains self-oscillation. Voltage regulation is imposed by a negative feedback loop from the output circuit. The duty cycle of the power switch is varied in response to the feedback signal, providing more "on" time to increase the average voltage from the L/C filter, less "on" time to decrease the average voltage. Current limiting signals from both the primary circuit and the output circuit are fed back through this same loop.

A "spike catcher" between the L/C filter and the inverter switch suppresses large transients that may be generated if conduction of the two transistors in the inverter switch overlaps. The inverter switch is two power transistors that are driven at 20 kHz, conducting alternately. The output of the inverter switch is fed to the transformer. Current is fed to each half of the transformer primary alternately in opposite directions. The inverter operates on a 50% duty cycle, producing square waves.

Each output voltage has its own full-wave rectifier and filter circuit. A coil in the toroidal transformer of each output is used to sense current in the circuit. This inductive coupling to the output current limiting circuit serves to isolate the output voltages from the primary side of the power supply, while establishing a feedback loop to the switching regulator amplifier. If current in any output tends to rise excessively, the negative feedback signal causes the switching regulator to decrease the "on" time of the power switch, reducing the average voltage applied to the inverter switch, which results in a reduction of the current through the transformer. The +5 volt output is compared to a reference voltage, and the difference is amplified and applied to the switching regulator amplifier via an opto-isolator, which isolates the output circuit from the primary circuit. The error signal is used to modify the duty cycle of the switch regulator in much the same way as in the current limiting circuit. Coupling between windings in the inverter transformer makes it possible to regulate all outputs by monitoring any one.

Overvoltage protection is provided by a silicon controlled rectifier connected across the +15 volt output. Under normal operating conditions, the SCR presents a very high resistance, but if the regulating circuit fails and a preselected limit is exceeded (nominally 5.6 volts on the +5 volt output), the SCR is fired, placing a short across the +15 volt output. This effectively shorts the entire transformer secondary. Current limiting then takes over automatically to protect the power supply.

2.11.2 Isolation

The primary circuits of the power supply are electrically isolated from the secondary, or output circuits. Note from the schematic diagram that there is no common ground reference between the primary and secondary circuits. While outputs are returned to the normal signal ground, primary circuits are returned to a "common return", NOT GROUND, indicated by a diamond on the schematic (◊). The only interfaces between the primary and secondary circuits are the inverter transformer (inductive), the output current limiter (inductive), and the optoisolator (optical).

WARNING

Hazardous voltages are present in the primary circuit.

CAUTION

When troubleshooting the primary side of the power supply under power, do not use test instruments having a third-wire ground, or damage to the instrument will result. Make measurements between circuit elements and the primary circuit common return, NOT ground.

2.11.3 Theory of Operation

The following paragraphs present a more detailed description of the operation of the power supply. Refer to the schematic diagram, No. 26021-xx, in the Schematics/Reference Section.

2.11.3.1 Input Current Limiting

When AC power is initially applied, electrolytic filter capacitor C23 demands a high rate of charging current. To protect the diodes in the rectifier, thermistor RT1 is inserted in the line. This thermistor has a negative coefficient of temperature, initially offering a relatively high resistance, then lowering resistance when current passing through it raises the temperature. The initial high resistance limits the charging rate of C23 to a safe level. When the temperature of RT1 rises, the resistance drops to a very low value. The AC ripple component from the rectifier is sufficient to keep the thermistor above the ambient temperature and at a low resistance.

2.11.3.2 Input RFI Filter

Switching power supplies tend to generate sharp transients, which can be reflected onto the power line. The purpose of the RFI filter is to suppress these switching transients. Inductor L1, the RFI filter has two windings with a common magnetic core. The two windings develop a higher Q and provide better filtering of both sides of the power line than two single inductors.

2.11.3.3 Full-Wave Bridge Rectifier

The full-wave rectifier, consisting of diodes CR1 through CR4 connected in a bridge configuration, converts the off-the-line AC directly into DC. Capacitor C23 provides filtering and storage of the rectified voltage. The cathode of C23 defines the primary circuit common return. Note that the rectifier is returned to the primary circuit common return, NOT to signal ground. Fuse F1, at the output of the rectifier, protects the diodes in the event of a catastrophic failure in the primary circuit. The output of the rectifier is then applied to the power switch, Q1, and to the local +15 volt power supply via a resistor-network.

2.11.3.4 Local +15 Volt Power Supply

Transistors Q5 and Q6 are the basic components of the local +15 volt regulated power supply that powers the switching regulator amplifier IC, U1. Zener diode VR1 and resistors R12, R13, and R14 provide a reference voltage that is compared by Q5 to the sampled voltage. The error signal developed is used to control Q6, the series-pass element, producing the required regulation.

2.11.3.5 Power Switch and Switching Regulator Amplifier

Power transistor Q1, the power switch, is controlled by Type 723 switching regulator amplifier U1, an integrated circuit voltage regulator, through a chain of power-boosting transistors. The switching signal generated within the IC at approximately 20 kHz turns the power switch on and off. Regulation is effected by modifying the duty cycle of the switch in response to feedback signals from the +5 volt output. Low output voltage results in increasing "on" time; high output causes a reduction in "on" time. Modifying the duty cycle raises or lowers the average voltage delivered to the inverter.

The output of U1 is boosted by transistor Q7 to drive complementary Darlington stage Q3. Q3, a PNP transistor, in turn drives Darlington-connected Q2, the immediate driver stage of Q1, the power switch. The 20 kHz chopped DC output from the power switch is applied to an LC filter for smoothing. The switch output signal is fed back to pin 4 of U1 via inductor L2 and resistors R27 and R17 to maintain self-oscillation. To overcome the effect of charge storage,

reverse emitter-base bias is injected into the power switch from a secondary winding on inductor L2. The reverse bias signal is applied via a network of resistors R2, R3, and R5, capacitor C5, and diode CR5. The phasing of the secondary of L2 causes a pulse of turn-off bias to be applied to both Q1 and Q2 at the termination of the switch "on" period. Turnoff of the switch becomes regenerative, and is greatly accelerated.

2.11.3.6 LC Smoothing Filter

The regulated, pulsed DC is applied to a filter network made up of inductor L2 and capacitor C10. Diode CR6 maintains output current flow during switch "off" periods by providing a current path to discharge the energy stored in the magnetic field of the inductor during "on" periods. CR6 is reverse-biased when the power switch is "on" to prevent upsetting DC conditions. The smoothed, regulated DC output of the filter is applied to the inverter via a "spike catcher" network.

2.11.3.7 Spike Catcher

The purpose of the spike catcher network, inductor L3, diode CR10, resistors R29 and R48, and capacitor C11, is to suppress large current spikes that can be generated when conduction of the two inverter transistors overlaps. This is not a common occurrence, but can happen during start-up or during recovery from an overload condition. This suppression not only reduces RFI radiation, but also protects the inverter transistors and the power switch transistor. Diode CR10 is polarized to damp production of counter emf's in L3 should transients occur in the inverter.

2.11.3.8 Inverter

The smoothed DC input is chopped at 20 kHz by the two power transistors, Q10 and Q11, which conduct alternately, feeding current to the two halves of the non-saturating output transformer T1 in opposite directions. Supporting circuitry consists of a saturating transformer, T2, diodes CR11 through CR15, resistors R29 through R32, and capacitor C12. The transformer is a self-excited type.

2.11.3.9 DC output Circuits

Each output has its own full-wave center-tap rectifier and low-pass LC filter. In addition, there are two electrolytic filter capacitors across the entire output from +15 volts to -15 volts. There is a bleeder resistor across the entire output, and one across the +5 volt supply to discharge the capacitors when power is turned off. The filters remove the high-frequency ripple component, mostly 40 kHz, from the output voltages.

The rectifier for the +15 volt supply is made up of transformer T6, diodes CR17 and CR22, and capacitors C35 and C38. Inductor L4 and capacitor C18 provide filtering. The -15 volt supply uses transformer T5, diodes CR18 and CR21, and capacitors C36 and C37. Filtering is provided by inductor L6 and capacitor C20. The +5 volt filter is a pi type consisting of inductor L5 and capacitors C39 and C43. The +5 volt filter is a pi type consisting of inductor L5 and capacitors C19 and C25. R54 is the +5 volt bleeder resistor. Filter capacitors C32 and C33, and bleeder resistor R51 are connected between the +15 and -15 volt outputs.

2.11.3.10 +5 Volt Error Amplifier

The +5 volt output is sampled by a voltage divider, resistors R43 and R44, and applied to the non-inverting input of Type 723 voltage regulator IC U2 via resistor R41. The adjustable reference voltage is derived from potentiometer R40 and applied to the inverting input of the voltage regulator via resistors R39 and R38. The two voltages are compared within U2, and the difference is applied to the Opto-isolator, U3. Only the +5 volt output is adjustable and regulated. The close electro-magnetic coupling in the transformer secondary makes it possible to control all output voltages by controlling any one.

2.11.3.11 Opto-isolator

The Opto-isolator, U3, consists of a solid-state lamp and a phototransistor. The output of the error amplifier is applied to the lamp, illuminating it in proportion to the error. The optical energy is read by the phototransistor, which has no electrical connection to its base. The output of the phototransistor is fed back through resistor R33 to the switching regulator amplifier, U1, where the signal is used to modify the duty cycle of the power switch, regulating the voltage. Since there is no direct electrical connection through the Opto-isolator, and the phototransistor output is returned to the primary circuit common return, the output circuit is effectively isolated from the primary.

2.11.3.12 Output Current Limiting Sense Amplifier

Current in a winding of a toroidal transformer in each output is monitored and fed back to the switching regulator amplifier to modify the switch duty cycle. Resistor R58 is connected across a winding of transformer T4 in the +5 volt circuit. Current through the transformer develops a voltage drop across the resistor. Transistors Q14 and Q15 sense and amplify the voltage drop. In the -15 volt supply, Resistor R59 is across the winding of T5, and transistors Q16 and Q17 are the sense amplifiers. In the +15 volt output, the circuit elements are transformer T6, resistor R60, and transistors Q18 and Q19. The collectors of all the transistors are connected to the base of transistor Q13 through resistor R70. Q13 amplifies the error signal, which can originate in any of the outputs, and applies it to the switching regulator amplifier along with the voltage regulation feedback signal. As current increases, the duty cycle of the switch regulator, and of the power switch, is modified to reduce switch "on" time, reducing the average voltage applied to the inverter, limiting current through the inverter transformer. A shorted output will reduce current to a very low level that can be tolerated indefinitely.

2.11.3.13 Overvoltage Protection

Overvoltage protection is provided primarily to protect the loads in the event of failure of the regulating circuit. Silicon controlled rectifier SCR1 is connected across the +15 volt output. The gate circuit of SCR1 monitors the +5 volt output through zener diode VR2, which has a 5.6 volt breakdown rating. If the +5 volt supply exceeds the zener breakdown voltage, the diode conducts, firing SCR2, which places a direct short across the +15 volt output. In effect, this "crowbars" all outputs because of the close coupling of the inverter transformer secondary. To protect the power supply, the current limiting circuit takes over, reducing the power switch output to a safe level. Once fired, the SCR will continue conducting until power is turned off. When the condition causing the overvolt condition is corrected and power is applied, the overvolt protect circuit is automatically restored to normal.

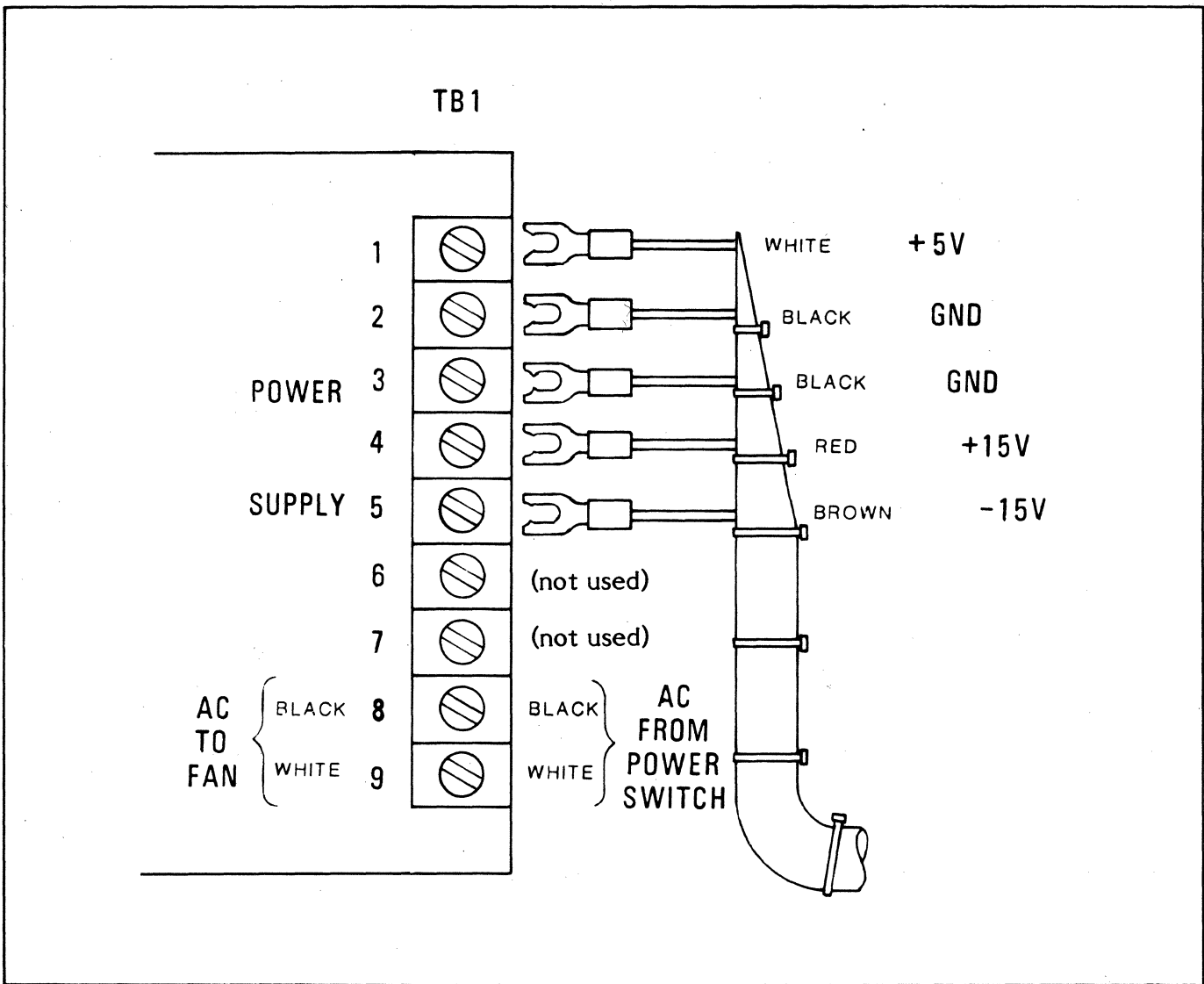

Figure 3-5. Power Supply Connections

- (5) Remove the XMEM board from slot (F), if installed, and install a circuit board extender into slot (F) behind the HPRO board.
- (6) Plug the HyTerm into the wall outlet.

to measure the voltage between pins 1-4 and the following locations on the circuit board extender:

Pins 5-6	+5.0V ± .1V
Pins 41-42	+15.25V ± .75V
Pins 49-50	+15.25V ± .75V
Pins 23-24	-15.25V ± .75V
Pins 31-32	-15.25V ± .75V

WARNING

When the HyTerm is connected to a power source, line voltage is present at the POWER switch terminals. To avoid a dangerous shock when power is applied and the top cover is not in place, keep your fingers away from the POWER switch terminals.

Turn on power and verify that a printer restore operation occurs. Use a digital voltmeter, if available,

WARNING

While power is on, do not tip the HyTerm up except to make a power supply adjustment. If this is necessary, be extremely careful not to touch any part of the power supply, because extremely high voltages (200-300 volts) are present. Use only non-metallic tools.

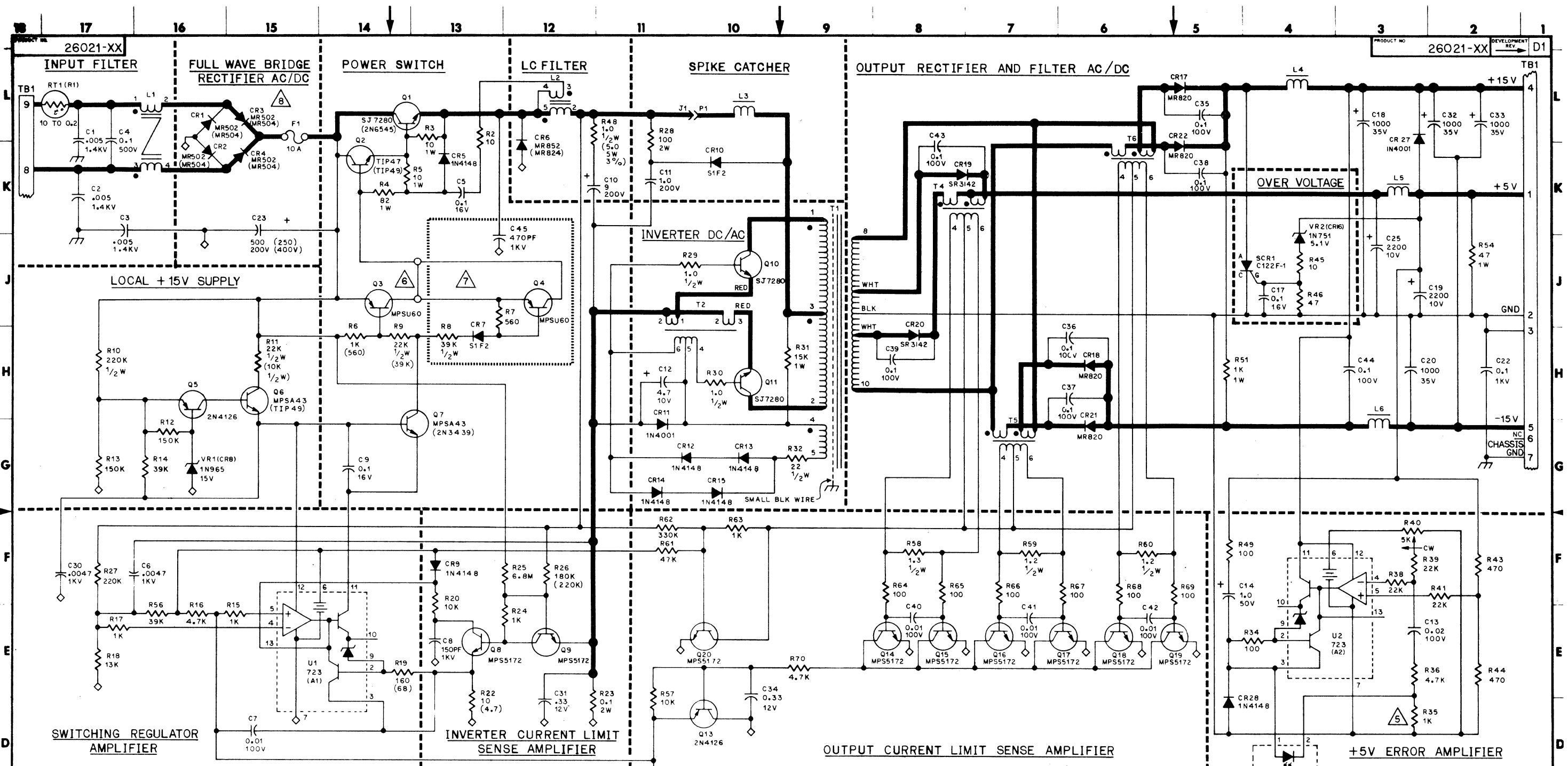

- NOTES: UNLESS OTHERWISE SPECIFIED,
 1. ALL RESISTANCES SPECIFIED IN OHMS.
 2. ALL RESISTORS ARE 1/4 WATT, ± 5%.
 3. ALL CAPACITANCE SPECIFIED IN MICROFARADS.
 4. ⚡ DENOTES PRIMARY CIRCUIT COMMON RETURN.
 5. SELECT TEST RESISTOR.
 6. INSTALL JUMPER FOR 115V (-01) OPERATION ONLY.
 7. INSTALL COMPONENTS FOR 220V (-02) OPERATION ONLY.
 8. USE COMPONENT VALUES IN PARENTHESES FOR 220V (-02) OPERATION ONLY.
 9. USE ONLY UNGROUNDED TEST INSTRUMENTS WHEN TROUBLE-SHOOTING PRIMARY CIRCUITS (ALL CIRCUITS OTHER THAN OUTPUT RECTIFIER AND FILTER, OVER VOLTAGE AND +5V ERROR AMPLIFIER).
 10. ALTERNATE REFERENCE DESIGNATORS SHOWN IN PARENTHESES ((CR8), (A1), ETC.) REFER TO SILKSCREENED INFORMATION ON SOME CIRCUIT BOARDS.

REFERENCE DESIGNATION	
LAST USED	NOT USED
C45	C15, 16, 21, 24, 26, 27, 28, 29
CR28	CR23, 24, 25, 26
F1	
L6	
Q20	Q12
RT0	R21, 37, 42, 50, 52, 53, 55
RT1	
SCR1	
T6	T3
U3	
VR2	

SCHEMATIC DIAGRAM

Diablo Systems Incorporated
 Hayward, California 94545

TITLE: POWER SUPPLY, BOSCHERT U.L., 115V/220V
 MODEL: 1610/1620

UNAUTHORIZED DISCLOSURE OR USE PROHIBITED.

DRAWINGS FURNISHED BY BOSCHERT ASSOCIATES FOR MAINTENANCE PURPOSES ONLY.

- NOTES:
1. CIRCUITRY (BACKGROUND) SHOWN IS LOCATED ON FAR SIDE.
 2. DRAWINGS FURNISHED BY BOSCHERT ASSOCIATES FOR MAINTENANCE PURPOSES ONLY.

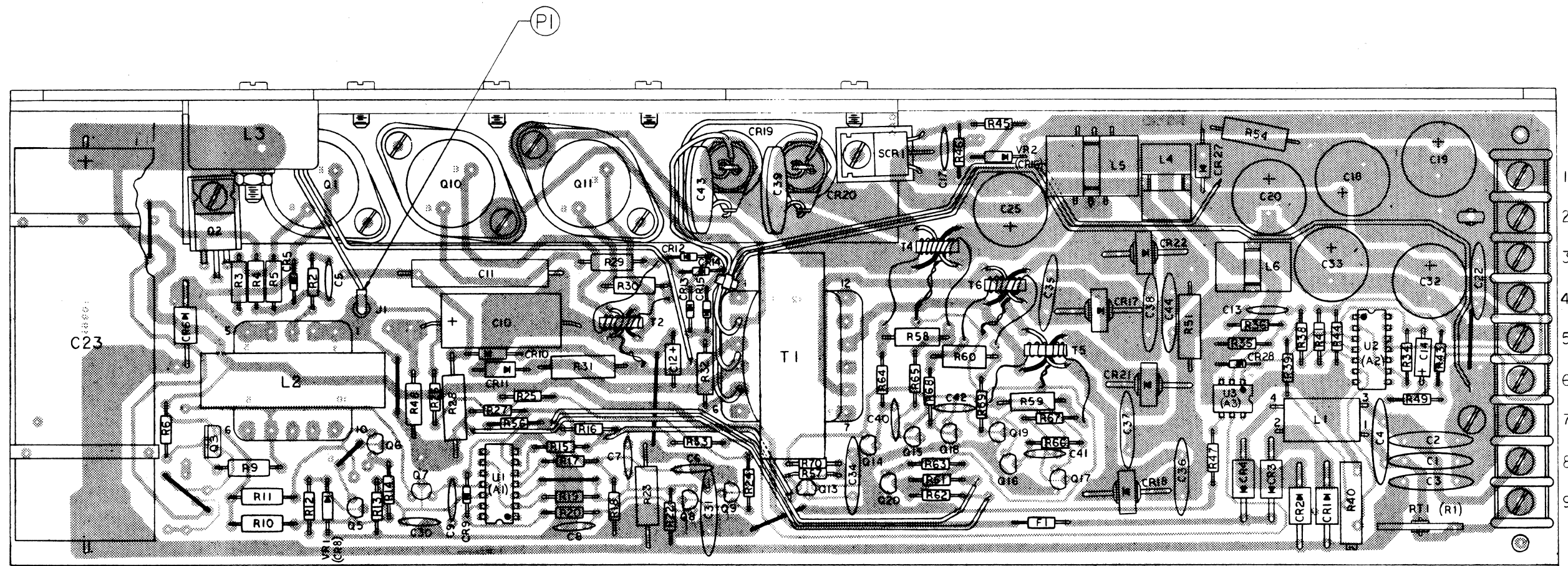

- TB1
- 1 [+5V]
- 2 [GND]
- 3 [GND]
- 4 [+15V]
- 5 [-15V]
- 6 [N.C.]
- 7 [CHAS GND]
- 8 [A.C. HOT]
- 9 [A.C. NEUT.]

115V.A.C. VERSION
(26021-01)

ASSEMBLY DRAWING

DIMENSIONS ARE IN INCHES UNLESS OTHERWISE SPECIFIED TOLERANCES ARE		DRAWN MATSUMOTO 11/11/76	DATE 11/11/76	 Diablo Systems Incorporated Hayward, California 94545
LINEAR	ANGULAR	CHECKED		
MATERIAL		ENGR. MKD	12/11/76	POWER SUPPLY
HEAT TREAT		15/11/76	12/21/76	BOSCHERT, U.L.
REVISIONS				SCALE NONE SHEET 3 TOTAL 4
NEXT ASSY. 26022	FINISH			SIZE D 26021-XX

- NOTES:
1. CIRCUITRY (BACKGROUND) SHOWN IS LOCATED ON FAR SIDE.
 2. DRAWINGS FURNISHED BY BOSCHERT ASSOCIATES FOR MAINTENANCE PURPOSES ONLY.

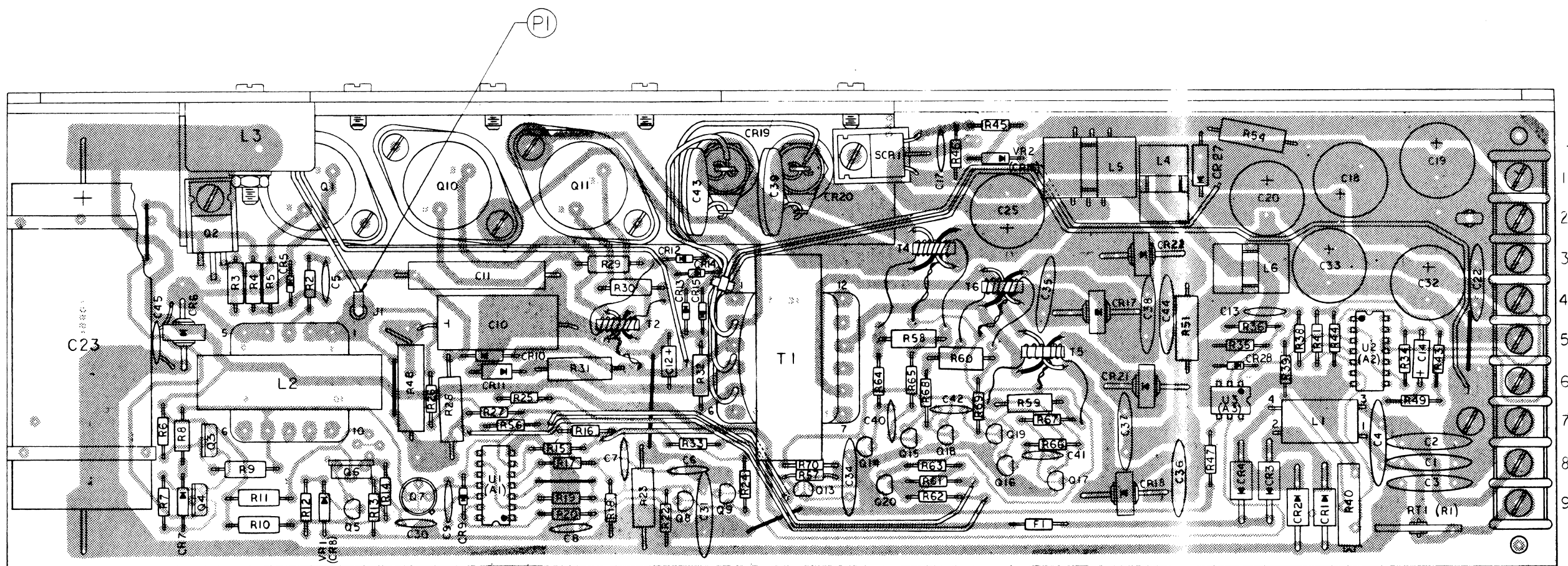

- TB1 [+5V]
- 2 [GND]
- 3 [GND]
- 4 [+15V]
- 5 [-15V]
- 6 [N.C.]
- 7 [CHAS GND]
- 8 [A.C. HOT]
- 9 [A.C. NEUT.]

220 V.A.C. VERSION
(26021-02)

ASSEMBLY DRAWING

DIMENSIONS ARE IN INCHES UNLESS OTHERWISE SPECIFIED TOLERANCES ARE		DRAWN MATSUMOTO	DATE 11/11/76	<p>Diablo Systems Incorporated Hayward, California 94545</p>
LINEAR	ANGULAR	CHECKED		
MATERIAL		ENGR.	11/21/76	POWER SUPPLY
FINISH		MG	12.21.76	BOSCHERT, U. L.
REVISIONS		SCALE NONE	SHEET 4	TOYBN 4
NEXT ASSY. 26022		SIZE D		26021-XX

REVISION HISTORY - #26021-XX POWER SUPPLY

Rev.	A	ECO#	7472	As released
	B		7504	Add requirement for label containing part number, serial number, and mfg. date code.
	C		7587	Add special label to 220V units.
	C1		7631	Add schematic and assembly drawings to part no.
	C2		7700	Correct minor schematic errors, add alternate reference designators.
	C3		7758	Correct error on connection drawing, sheet 1.
	C4		7899	Move cathode of diode CR27 from input to output of L4; reduces 5V ripple.

Make the following component changes:

<u>Component</u>	<u>Was</u>	<u>Is</u>
R3,R4,R5	¼ Watt	1Watt
Q1	SJ7280(2N6308)	SJ7280(2N6545)
Q3,Q4	MPSA93	MPSU60
CR19,CR20	1N3889	SR3142
R8	22K	39K
R9	22K	22K(39K)
R19	160(33)	160(68)
R22	10(2.2)	10(4.7)

NOTE: Component values in parentheses are for 220V operation